

DFG460-4

Diamond Floor Grinder

Operating Manual

This manual is provided to persons purchasing an SPE machine and may not be reproduced in part or full without written permission of SPE International Ltd.

This manual provides the basic information required and is only to be used as a guideline. The SPE machines are manufactured and covered by SPE design registrations granted and pending. SPE International Ltd reserves the right to alter the equipment design and specification as required without notice.

The SPE product range is subject to amendment and improvement as a result of on going research



Honeyholes Lane, Dunholme, Lincoln LN2 3SU, England
Tel: +44 (0) 1673 860709 Fax: +44 (0) 1673 861119
Email: sales@spe-int.com



DFG460-4
Operating Manual

DFG460 Triple Head Floor Grinder

OPERATING MANUAL

This manual covers to the best of our knowledge the operation and maintenance of the **DFG460-4** diamond floor grinder. Before operation of the equipment the manual should be read and understood by the operator. The safety regulations must be followed at all times. Service of electrical components should be carried out by authorised personnel.

WARNING

Failure to follow these instructions may result in serious personal injury or death. SPE disclaims all responsibility for damage to persons or objects arising as a consequence of incorrect handling of the machine and failure to inspect the machine for damage or other faults that may influence the operation prior to starting work.

INDEX

Page No

1	Starting Work
2	DFG460 Tooling
3	Maintenance
4	Safety
5	Spare Parts Breakdowns
6-7	Main Gearbox Assembly
8-9	Main Drive Assembly
10-11	Pivot Frame Assembly
12-13	Axle Frame Assembly
14-15	Adjustable Strut Assembly
16-17	Handle Assembly
18-19	Drive Gear Assembly
20-21	Intermediate Gear Assembly
22-23	Driven Gear Assembly
24	Electrical Components
25	Specification Sheet
26	Warranty
27	Declaration of Conformity
28	Conditions of Sale



STARTING WORK

1. BEFORE STARTING WORK ENSURE THAT THE GRINDING HEADS HAVE BEEN FITTED, SEE PAGE 2
2. Ensure the power supply is correct for DFG460-4 - This should be a 220v 16 amp supply from the mains or generated with a minimum of 8 kVA on 50 cycles.
3. Connect a vacuum to the port at the rear of the machine to control the dust.
4. The height of the operating handle can be adjusted by using the hand-wheel at the rear of the machine. Turning the hand-wheel anti-clockwise will raise the handle and clockwise will lower the handle.

The grinding head of the machine can pivot and the movement can be altered by adjusting the two grinding head stops at the front and rear of the frame.
5. After connecting the machine to the power supply turn the red isolator switch to the ON position. The red light will illuminate on the electric panel.
6. Turn on the vacuum.
7. Ensure that the emergency stop button is out by turning clockwise.
8. Turn the speed control knob on top of the electrical panel to a low speed setting.
9. Press the green button on top of the electrical panel. The green light will illuminate and the inverter will power up. There may be a delay of 2-3 seconds before the electric motor starts.
10. To increase the grinding speed, turn the speed control knob on top of the electrical panel to the next level. With experience the operator will be able to feel the correct speed setting for the grinding process.
11. To stop the machine, press the red emergency stop button.

The machine can be disassembled to enable it to fit into a small vehicle. Unplug the motor lead from the electrical panel then take out the pins in the yokes at the base of the main handle and also the one at the bottom of the height adjustment tube, lift the handle assembly from the frame of the machine.



DFG460 TOOLING

The DFG460 is fitted with three drive plates that use a quick release tooling system. These are fitted to the machine with three countersunk screws per plate. Ensure that these plates are securely fastened to the machine prior to fitting any tools.

METAL GRINDING TOOLS

1. Disconnect the machine from the power supply.
2. Tip the DFG460 backwards onto the operator handle. The machine must be secured and supported.
3. Fit the metal tools into the drive plates by locating the dovetail on the back of the tool into the chamfered slot in the drive plate and slide outwards. Give the tool a tap outwards to lock into position.
4. Repeat the above process to fit the other eight tools into the drive plates.
5. Removal of existing tools is the reverse of the above. Tap the tool inwards to unlock and slide out of the slot in the drive plate.
6. After fitting the tools, gently lower the machine back onto the floor surface.

RESIN POLISHING TOOLS

The resin tools are fitted as a two piece system. Fitting will require a set of resin tool holders (part no 5495 (x9)) with the Velcro backing that will accept most standard 60mm diameter Velcro backed resin tools.

1. Disconnect the machine from the power supply.
2. Tip the DFG460 backwards onto the operator handle, the machine must be secured and supported.
3. Fit the resin tool holders into the drive plates by locating the dovetail on the back of the tool holder into the chamfered slot in the drive plate and slide outwards, give the tool a tap outwards to lock into position.
4. Repeat the above process to fit the other eight tool holders into the drive plates.
5. Once all the tool holders are in place, press on the required resin tools onto the velcro backing.
6. Changing resin tools only involves removing from the tool holder and replacing. To remove the tool holders, tap inwards to unlock and slide out of the slot in the drive plate.
7. After fitting of the tools, gently lower the machine back onto the floor surface.

NOTE: Always use the same type and bond of tool on each of the three heads, equally worn tools must be fitted as a set.

To ensure the correct tool is being used, check wear rates after quarter of an hour and again at half hourly intervals, this will give an indication of total wear rates and cost per square metres.



MAINTENANCE

AFTER USE:

- Clean the machine to remove all build up of dust and surface residue. If using a hose pipe or pressure washer, take care that water is not directed onto electrical components and switches. (Note: Motors and switches are not waterproof)
- Ensure the height adjustment thread is cleaned and then lightly oiled. Periodically it should be removed and the female threaded section cleaned out and oiled regularly to maintain a light, smooth height adjustment.
- The flexible couplings that support the drive plates should be checked on a weekly basis, the couplings should be firm without excessive movement.
- The planetary gear case is sealed and should not require any maintenance, the internal gears are lubricated with Lithium EPO grease.
- All components should be checked daily for tightness.
- All plugs, sockets and electrical leads should be checked for condition and damage.
- Periodically check the oil level in the drive gearbox. Ensure that the machine is level and remove the top blanking plug from the gearbox at the front of the machine. If oil comes out of the hole when the plug is removed then the gearbox contains sufficient oil, if not then top up the gear box using a SY320 grade gear oil.



DFG460-4
Operating Manual

SAFETY

Only trained operatives should be allowed to work the **DFG460** range of floor grinders.

Note: It is possible that the noise level produced by the Diamond Floor Grinder could exceed 90dbA. Appropriate PPE must be worn and the equipment must be used in line with guidelines laid down by the Health & Safety Executive.

Always ensure that all power leads and hoses are disconnected before attempting to service the machine. Never tip the machine backwards until the grinding plates have stopped rotating and the machine has been isolated at the main supply.

Noise and vibration will occur at various levels dependent on the grinding attachments and work being completed. It is recommended that tests are taken on site to provide the operator with accurate information on using the equipment within the guidelines laid down by the Health & Safety Executive.

NOTE:

1. **NEVER OPERATE THE DFG460 FLOOR GRINDER OUTDOORS IN WET CONDITIONS AS THE ELECTRICAL COMPONENTS ARE NOT WATERPROOF**
2. **NEVER OPERATE THE DFG460 WITH THE HEADS RAISED FROM THE FLOOR**
3. **THE SERVICE OF ELECTRICAL COMPONENTS SHOULD BE CARRIED OUT BY AUTHORISED PERSONNEL ONLY.**



DFG460-4
Operating Manual

Spare Parts Breakdown

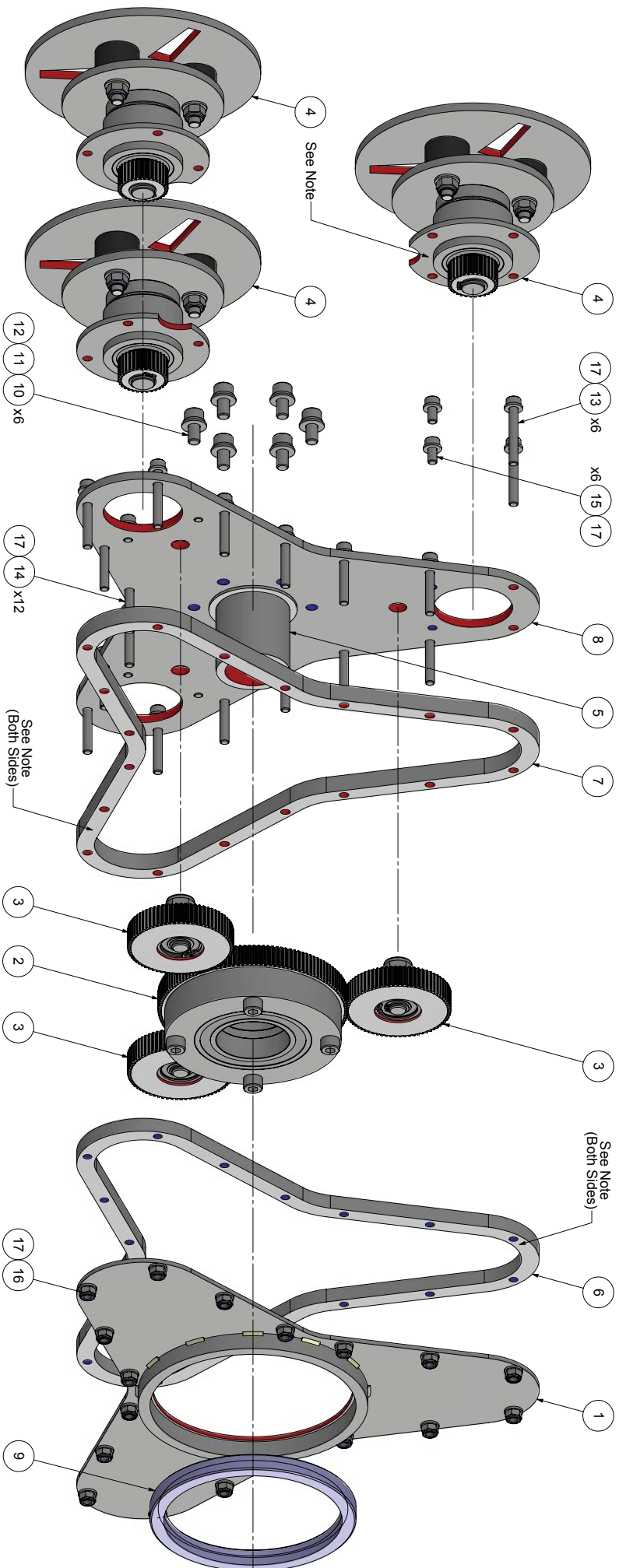

Note: Seal Gearbox On Assembly With Gasitite Multi Purpose Silicone Sealant (Clear)

Plan Elevation Of Gearbox
(With Top Plate Removed)
On Assembly Gears To Mesh
Smoothly And Run Together
Without Binding.

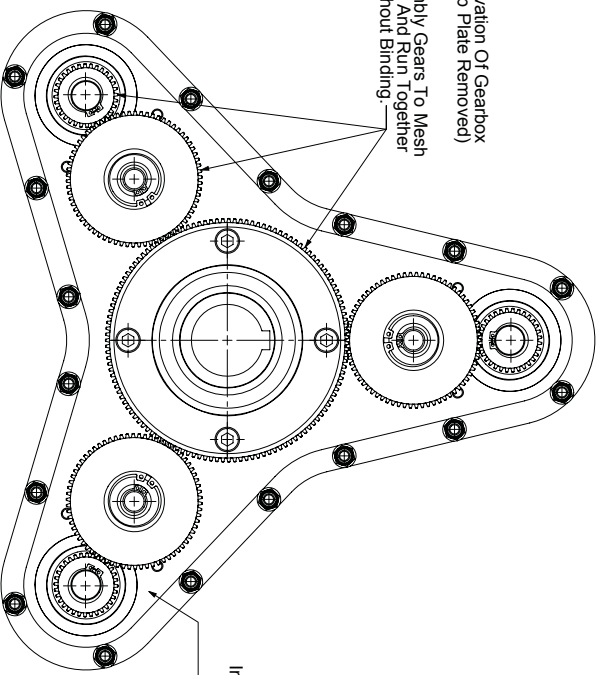

Important: Fill With 200g
Of EP00 Lithium
Grease On Assembly

Remove Sharp Edges & Corners
All Machined Surfaces To Be Square & Parallel

REVISIONS		DATE	APPROVED
REV	DESCRIPTION		
1	INITIAL RELEASE	20/10/2013	BJ

<p>ALL DIMENSIONS IN MM UNLESS OTHERWISE STATED</p> <p>GENERAL TOLERANCE ±0.5MM UNLESS OTHERWISE STATED</p> <p>THIRD ANGLE</p>		<p>Remove Sharp Edges & Corners All Machined Surfaces To Be Square & Parallel</p>	<p>SPB International Ltd Honeygoles Lane, Dunholme, Lincolnsire, LN2 3SU England</p>	<p>THIS DOCUMENT IS PRIVATE AND CONFIDENTIAL. IT IS THE PROPERTY OF SPB INTERNATIONAL. IT MUST NOT BE COPIED OR SUBMITTED TO ANY THIRD PARTY WITHOUT THE CONSENT OF SPB INTERNATIONAL LTD.</p>
<p>SPB SURFACE PREPARATION EQUIPMENT</p> <p>Tel: +44 (0) 1473 840709/860330 Fax: +44 (0) 1473 861119 Web Site: http://www.spb-int.com E-mail: info@spb-int.com</p>	<p>DFG-460 Main Gearbox Assembly</p> <p>FINISH MATERIAL DRAWN BY GDC SCALE DATE 1:2 16/10/2013</p>	<p>DRAWING No. DFG-460-0004-1</p>	<p>A2</p>	



DFG460-4
Operating Manual

MAIN GEARBOX ASSEMBLY

ITEM	QTY	PART NUMBER	DESCRIPTION
1	1	5504	Upper Gear Plate
2	-	See drawing no. DFG-460-0066-1	Page 18-19
3	-	See drawing no. DFG-460-0067-1	Page 20-21
4	-	See drawing no. DFG-460-0068-1	Page 22-23
5	1	5525	Main Hub
6	1	5505	Upper Gear Ring
7	1	5506	Lower Gear Ring
8	1	5507	Lower Gear Plate
9	1	7424	Lip Seal
10	6	BOLT246	M8 x 16 Cap HD Skt Screw
11	6	WASHER004	M8 Flat Washer
12	6	WASHER024	M8 Spring Washer
13	6	BOLT226	M6 x 45 Cap HD Skt Screw
14	12	BOLT225	M6 x 40 Cap HD Skt Screw
15	6	BOLT224	M6 x 12 Cap HD Skt Screw
16	18	NUT043	M6 Nyloc Nut
17	24	WASHER003	M6 Flat Washer

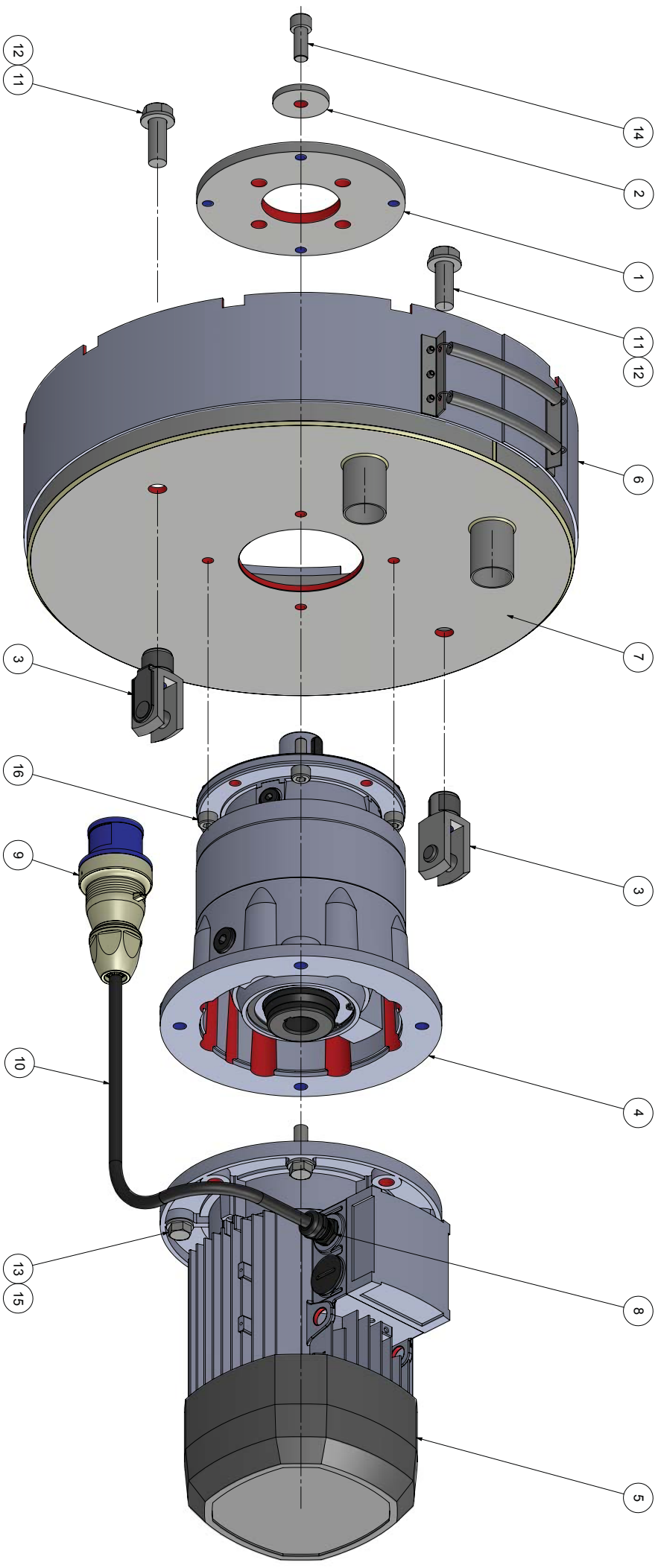

Note: All Fasteners To Be Secured With Locktite 243 On Assembly

REVISIONS			
REV	DESCRIPTION	DATE	APPROVED
1	INITIAL RELEASE	29/10/2013	BJ

<p>ALL DIMENSIONS IN MM UNLESS OTHERWISE STATED</p> <p>GENERAL TOLERANCE ±0.5MM UNLESS OTHERWISE STATED</p> <p>THIRD ANGLE</p>		<p>Tab: +44 (0) 1473 840709/860330</p> <p>Fax: +44 (0) 1473 861119</p> <p>Web Site: http://www.spe-int.com</p> <p>E-mail: info@spe-int.com</p>	<p>SPE</p> <p>SPE International Ltd Honeyrobes Lane, Dunholme, Lincolnshire, LN2 3SU England</p>	<p>THIS DOCUMENT IS PRIVATE AND NOT BE LOANED, REPRODUCED, COPIED, REPRODUCED, OR DISTRIBUTED TO ANY THIRD PARTY WITHOUT THE CONSENT OF SPE INTERNATIONAL LTD.</p>	<p>DRAWING No. DFG-460-0006-1</p>	<p>A2</p>
--	--	---	---	--	--	------------------

REV	DESCRIPTION	DATE	APPROVED
1	INITIAL RELEASE	29/10/2013	BJ

<p>ALL DIMENSIONS IN MM UNLESS OTHERWISE STATED</p> <p>GENERAL TOLERANCE ±0.5MM UNLESS OTHERWISE STATED</p> <p>THIRD ANGLE</p>		<p>Tab: +44 (0) 1473 840709/860330</p> <p>Fax: +44 (0) 1473 861119</p> <p>Web Site: http://www.spe-int.com</p> <p>E-mail: info@spe-int.com</p>	<p>SPE</p> <p>SPE International Ltd Honeyrobes Lane, Dunholme, Lincolnshire, LN2 3SU England</p>	<p>THIS DOCUMENT IS PRIVATE AND NOT BE LOANED, REPRODUCED, COPIED, REPRODUCED, OR DISTRIBUTED TO ANY THIRD PARTY WITHOUT THE CONSENT OF SPE INTERNATIONAL LTD.</p>	<p>DRAWING No. DFG-460-0006-1</p>	<p>A2</p>
--	--	---	---	--	--	------------------



DFG460-4
Operating Manual

MAIN DRIVE ASSEMBLY

ITEM	QTY	PART NUMBER	DESCRIPTION
1	1	5520	Gearbox Retaining Plate
2	1	5539	Gearbox Lock Washer
3	2	5513	Yoke & Clevis Pin
4	1	5511	Gearbox
5	1	6058	Electric Motor
6	1	5512	Dust Skirt
	2	7331	Dust Skirt Spring
7	1	5503	Cowl
8	1	SPCG/LNM20	Cable Gland
9	1	SP210-409	16A 4Pin Trailing Plug
10	1	7520	2-5mm ² Armoured Cable
11	2	BOLT094	M16 x 45 Set Screw
12	2	WASHER008	M16 Flat Washer
13	4	BOLT082	M12 x 40 Set Screw
14	1	BOLT282	M12 x 30 Cap HD Skt Screw
15	4	WASHER006	M12 Flat Washer
16	4	BOLT263	M10 x 30 Cap HD Skt Screw

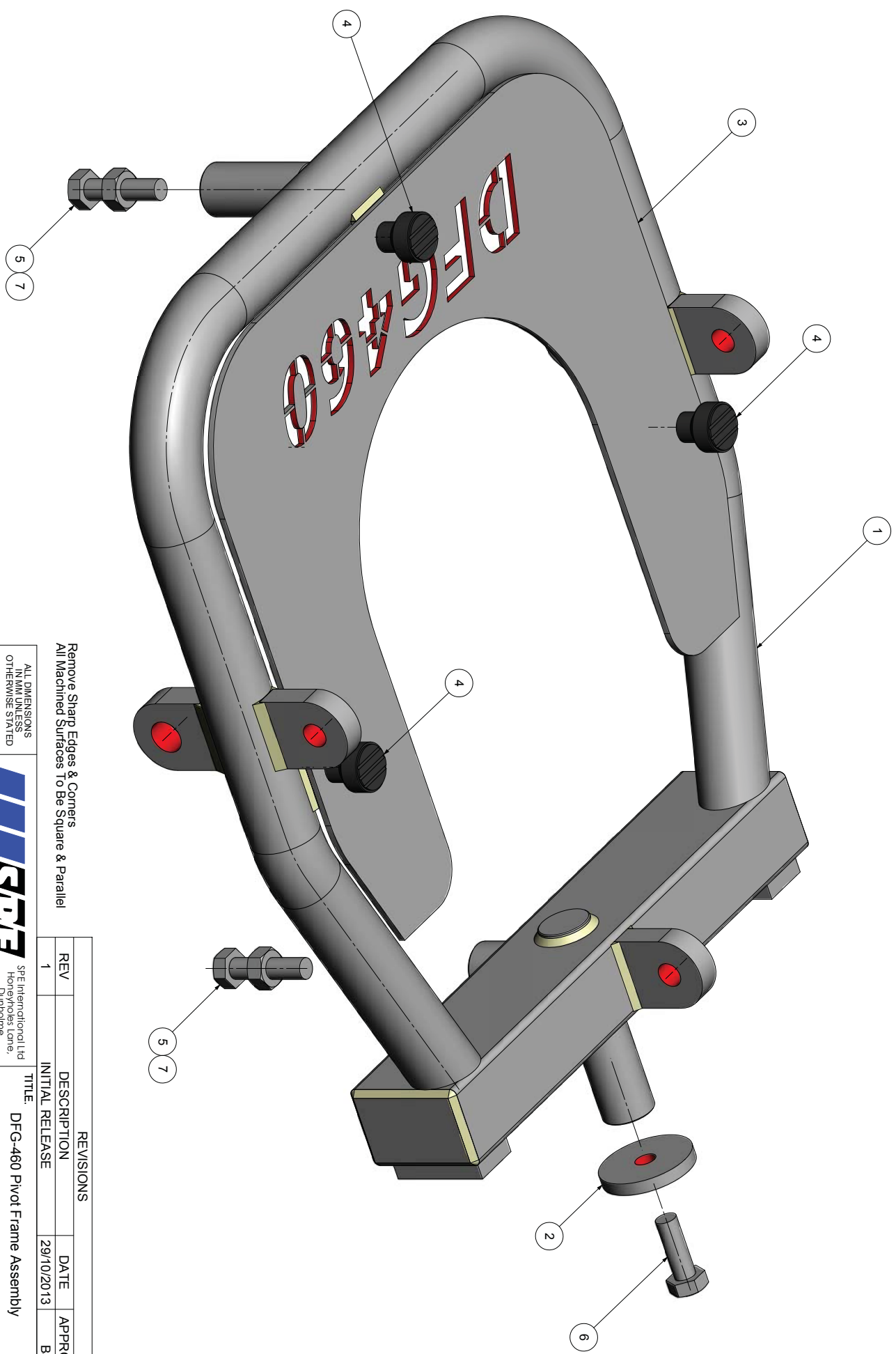

Remove Sharp Edges & Corners
All Machined Surfaces To Be Square & Parallel

REV		DESCRIPTION	DATE	APPROVED
1		INITIAL RELEASE	29/10/2013	BJ

TITLE	DFG-460 Pivot Frame Assembly
FINISH	
MATERIAL	
DRAWN BY	GDC
SCALE	NTS
DATE	08/10/2013

ALL DIMENSIONS IN MM UNLESS OTHERWISE STATED	GENERAL TOLERANCE ±0.5MM UNLESS OTHERWISE STATED
--	--

<p>THIRD ANGLE</p>	<p>SPPE SURFACE PREPARATION EQUIPMENT</p>	<p>THIS DOCUMENT IS PRIVATE AND NOT BE LOANED, REPRODUCED, COPIED, EITHER WHOLLY OR IN PART, OR BY ANY MEANS, WITHOUT THE WRITTEN CONSENT OF SPPE INTERNATIONAL LTD.</p>
<p>SPPE International Ltd Honeyrobes Lane, Dunholme, Lincolnshire, LN2 3SU England</p>	<p>Tel: +44 (0) 1473 840709/860330 Fax: +44 (0) 1473 861119 Web Site: http://www.sppe-int.com E-mail: info@sppe-int.com</p>	<p>DRAWING No. DFG-460-0017-1</p>

Note: All Fasteners To Be Secured With Locktite 243 On Assembly



DFG460-4
Operating Manual

PIVOT FRAME ASSEMBLY

ITEM	QTY	PART NUMBER	DESCRIPTION
1	1	5501	Frame
2	1	5540	Frame Lock Washer
3	1	5508	Cover Plate
4	3	5515	Thumb Screw
5	2	BOLT064	M10 x 40 Set Screw
6	1	BOLT062	M10 x 30 Set Screw
7	2	NUT005	M10 Nut

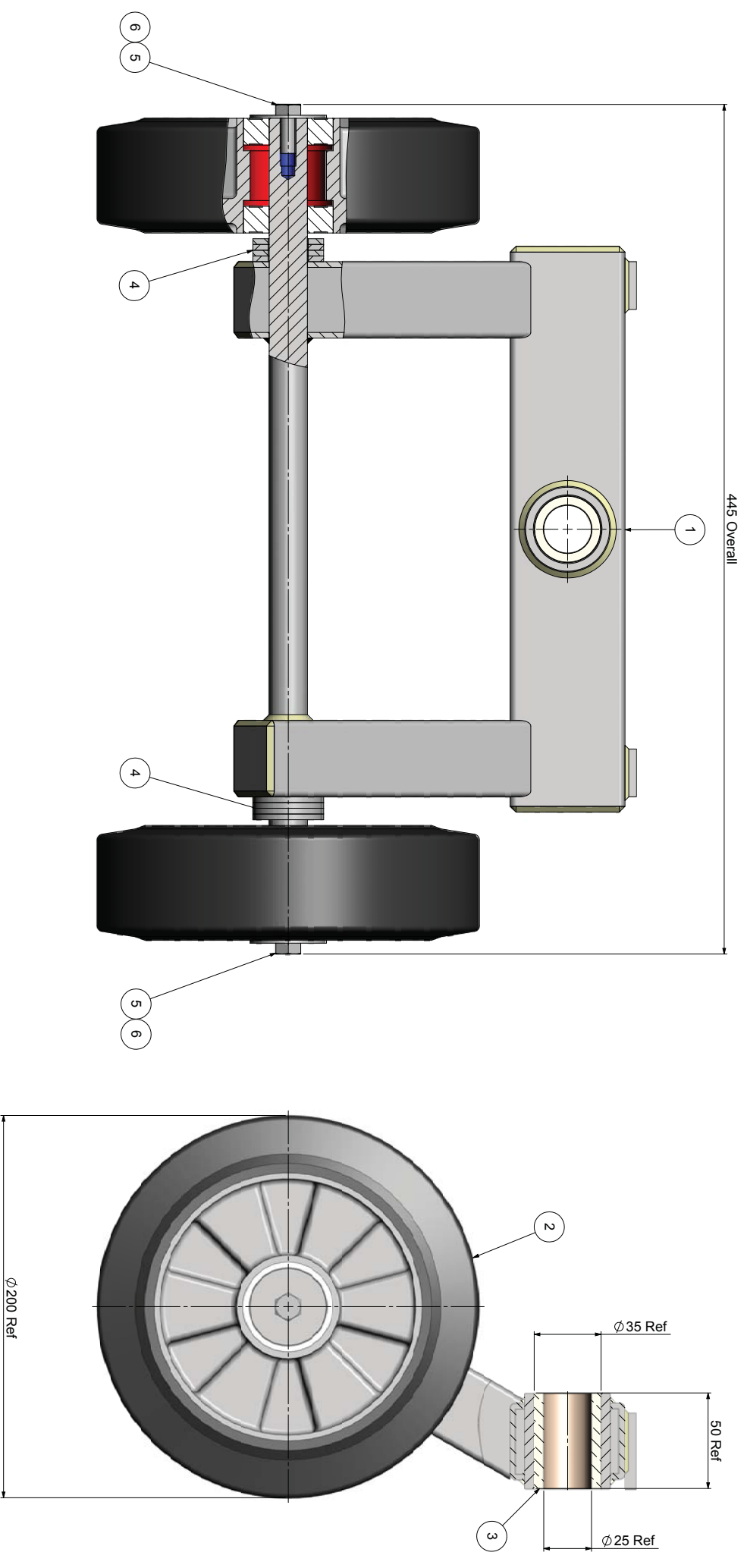

Note: All Fasteners To Be Secured With Locktite 243 On Assembly

REVISIONS			
REV	DESCRIPTION	DATE	APPROVED
1	INITIAL RELEASE	29/10/2013	BJ

<p>ALL DIMENSIONS IN MM UNLESS OTHERWISE STATED</p> <p>GENERAL TOLERANCE ±0.5MM UNLESS OTHERWISE STATED</p> <p>THIRD ANGLE</p>		<p>SPRINT</p> <p>SURFACE PREPARATION EQUIPMENT</p> <p>Tel: +44 (0) 1273 842070/860330 Fax: +44 (0) 1273 861119 Web Site: http://www.sps-int.com E-mail: info@sp-int.com</p>	<p>THIS DOCUMENT IS PRIVATE AND NOT BE LOANED, REPRODUCED, COPIED, EITHER WHOLLY OR IN PART, OR BY ANY MEANS, WITHOUT THE WRITTEN CONSENT OF SPRINT INTERNATIONAL LTD.</p>
<p>DF-G-360 Axle Frame Assembly</p> <p>FINISH: - MATERIAL: - DRAWN BY: GDC SCALE: NTS DATE: 09/10/2013</p>	<p>DFG-460-0031-1</p>	<p>DFG-460-0031-1</p>	<p>A2</p>



DFG460-4
Operating Manual

AXLE FRAME ASSEMBLY

ITEM	QTY	PART NUMBER	DESCRIPTION
1	1	5541	Axle Assembly
2	14	WASHER009	M20 Flat Washer
3	2	2013	Rear Wheel
4	1	5031	Oilite Bush
5	2	BOLT042	M8 x 20 Set Screw
6	2	WASHER053	M8 x 40 Repair Washer

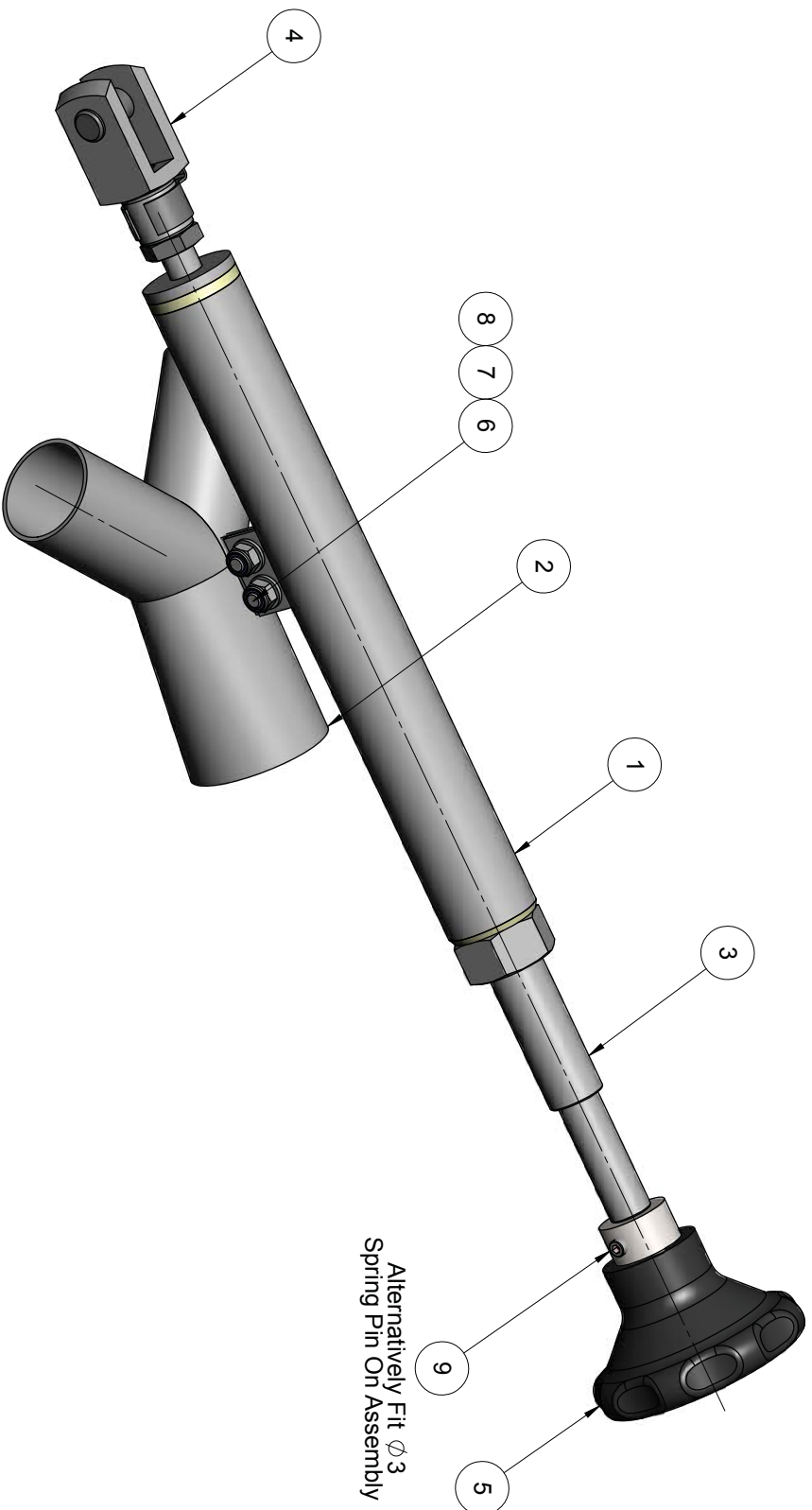

REVISIONS			
REV.	DESCRIPTION	DATE	APPROVED
1	INITIAL RELEASE	29/10/2013	BJ

ALL DIMENSIONS
IN MM UNLESS
OTHERWISE STATED

GENERAL TOLERANCE
±0.5MM UNLESS
OTHERWISE STATED



SPE International Ltd
Homeyholes Lane,
Dunholme,
Lincolnshire,
LN2 3SU,
England

SURFACE PREPARATION EQUIPMENT

TITLE:		DFG-460 Adjustable Strut Assembly		QTY	
FINISH	MATERIAL	DRAWN BY	GDC	-	
-	-	SCALE	NTS	-	
DRAWING No.		DATE	10/10/2013	-	

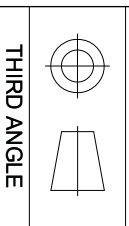

Tel: +44 (0) 1673 860709/860330
 Fax: +44 (0) 1673 861119
 Web Site: <http://www.spe-int.com>
 E-mail: info@spe-int.com

THIS DOCUMENT IS PRIVATE AND
CONFIDENTIAL AND THE PROPERTY
OF SPE INTERNATIONAL LTD. IT MUST
NOT BE COPIED OR SUBMITTED TO
ANY THIRD PARTY WITHOUT THE
CONSENT OF SPE INTERNATIONAL LTD.

DWG No. **DFG-460-0040-1**

A3

Remove Sharp Edges & Corners
All Machined Surfaces To Be Square & Parallel



DFG460-4
Operating Manual

ADJUSTABLE STRUT ASSEMBLY

ITEM	QTY	PART NUMBER	DESCRIPTION
1	1	5509	Height Rod
2	1	5510	Hose Y Piece
3	1	5518	Height Screw
4	1	9122	Yoke & Clevis Pin
5	1	5519	Handwheel
6	2	BOLT227	M6 x 16 Cap HD Skt Screw
7	2	NUT043	M6 Nyloc Nut
8	2	WASHER003	M6 Flat Washer
9	1	BOLT302	M6 Grub Screw

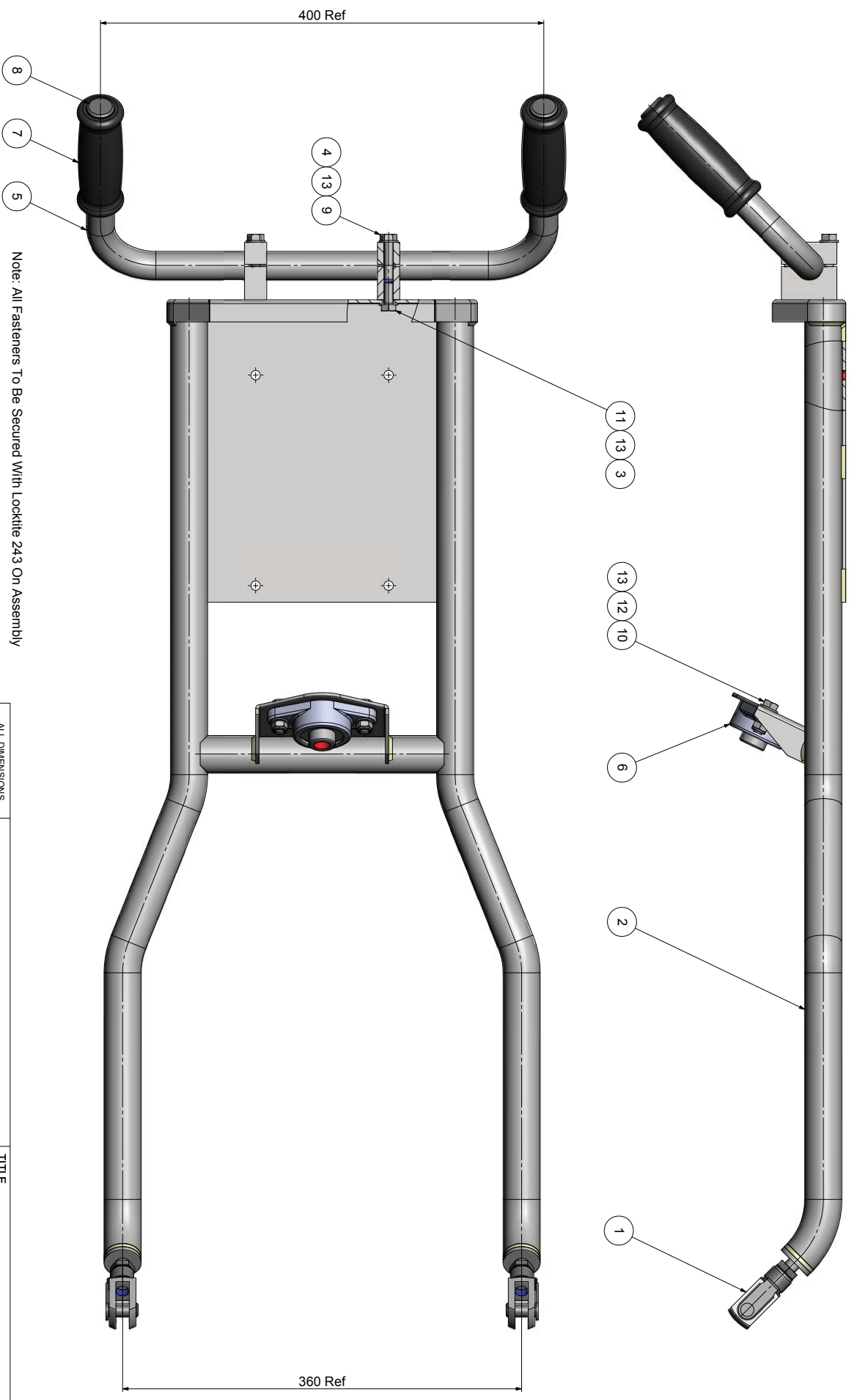

Note: All Fasteners To Be Secured With Locktite 243 On Assembly

REV	DESCRIPTION	DATE	APPROVED
1	INITIAL RELEASE	29/10/2013	BJ

<p>ALL DIMENSIONS IN MM UNLESS OTHERWISE STATED</p> <p>GENERAL TOLERANCE ±0.5MM UNLESS OTHERWISE STATED</p>	<p>THIRD ANGLE</p>
---	--------------------

SPE
 SURFACE PREPARATION EQUIPMENT
 Tel: +44 (0) 1473 840709/860330
 Fax: +44 (0) 1473 861119
 Web Site: <http://www.spe-int.com>
 E-mail: info@spe-int.com

SPE International Ltd
 Honeyholes Lane,
 Dunholme,
 Lincobshire,
 LN2 3SU
 England

THIS DOCUMENT IS PRIVATE AND
 CONFIDENTIAL. IT IS THE PROPERTY
 OF SPE INTERNATIONAL LIMITED AND
 NOT BE COPIED OR SUBMITTED TO
 ANY THIRD PARTY WITHOUT THE
 CONSENT OF SPE INTERNATIONAL LTD

TITLE		QTY	
DFG-460 Handle Assembly		-	
FINISH	MATERIAL	DRAWN BY	GDC
-	-	SCALE	1:2.5
DRAWING No.	DATE	14/10/2013	
DFG-460-0053-1		A2	



DFG460-4
Operating Manual

HANDLE ASSEMBLY

ITEM	QTY	PART NUMBER	DESCRIPTION
1	2	9122	Yoke & Clevis Pin
2	1	5502	Handle Assembly
3	2	5516	Handle Clamp
4	2	5516	Handle Clamp
5	1	5517	Handle Bar
6	1	9134	Bearing
7	2	9104	Hand Grip
8	2	TI/011	Tube End
9	4	BOLT045	M8 x 35 Set Screw
10	2	BOLT043	M8 x 25 Set Screw
11	4	BOLT042	M8 x 20 Set Screw
12	2	NUT044	M8 Nyloc Nut
13	12	WASHER004	M8 Flat Washer

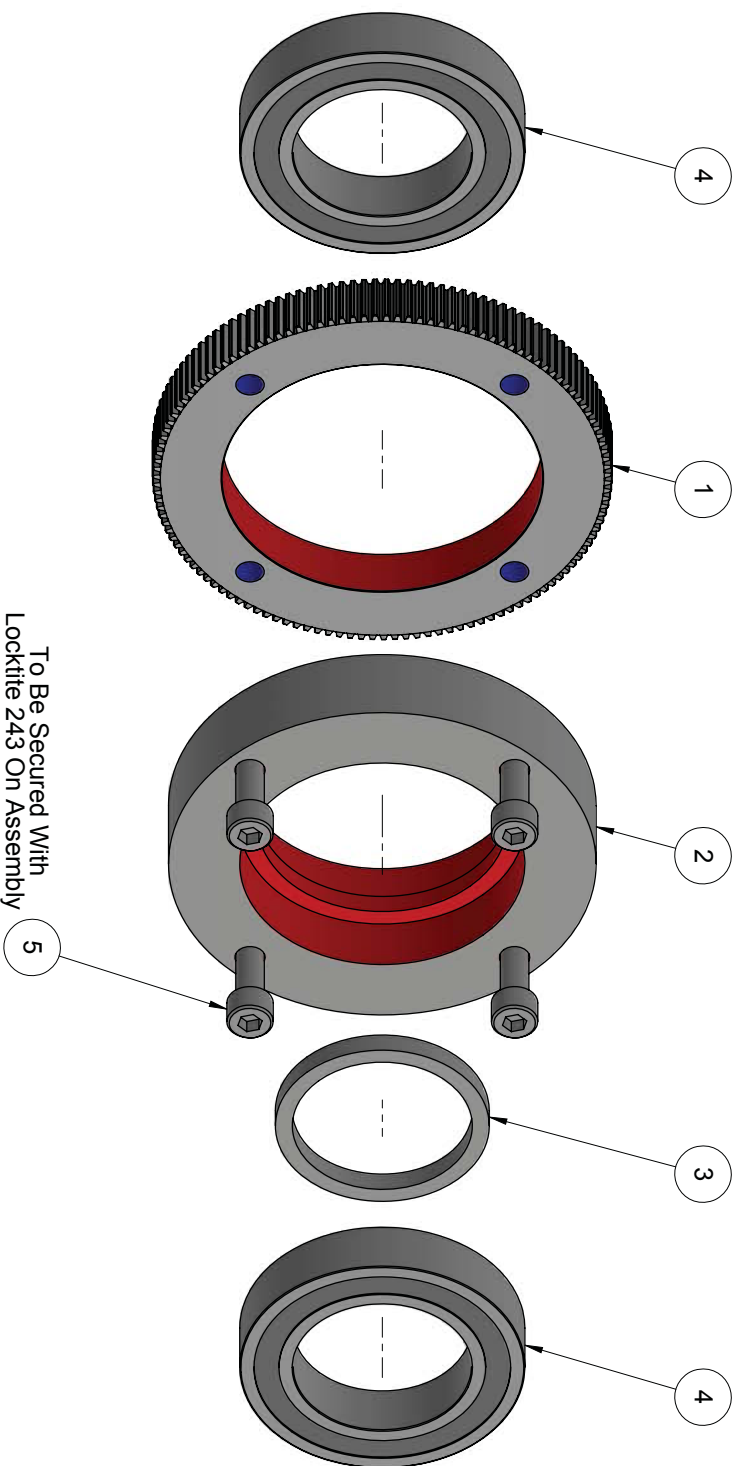
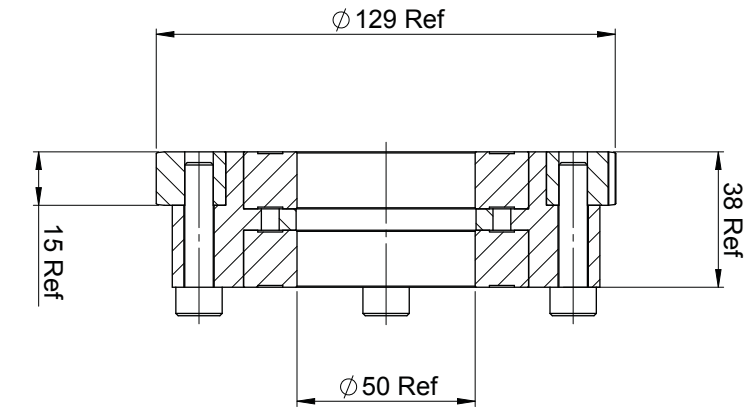

To Be Secured With
Loctite 243 On Assembly

REVISIONS

REV.	DESCRIPTION	DATE	APPROVED
1	INITIAL RELEASE	29/10/2013	BJ

ALL DIMENSIONS
IN MM UNLESS
OTHERWISE STATED

GENERAL TOLERANCE
 ± 0.5 MM UNLESS
OTHERWISE STATED



SPE International Ltd
Honeyholes Lane,
Dunholme,
Lincolnshire,
LN2 3SU,
England

TITLE:
DFG-460 Drive Gear Assembly

FINISH MATERIAL DRAWN BY GDC

SCALE DATE 15/10/2013

DRAWING No.

DFG-460-0066-1

A3

Remove Sharp Edges & Corners
All Machined Surfaces To Be Square & Parallel

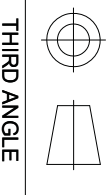

Tel: +44 (0) 1673 860709/860330
Fax: +44 (0) 1673 861119
Web Site: <http://www.spe-int.com>
E-mail: info@spe-int.com

THIS DOCUMENT IS PRIVATE AND
CONFIDENTIAL AND THE PROPERTY
OF SPE INTERNATIONAL LTD. IT MUST
NOT BE COPIED OR SUBMITTED TO
ANY THIRD PARTY WITHOUT THE
CONSENT OF SPE INTERNATIONAL LTD.



DFG460-4
Operating Manual

DRIVE GEAR ASSEMBLY

ITEM	QTY	PART NUMBER	DESCRIPTION
1	1	5524	Drive Gear
2	1	5521	Bearing Housing
3	1	5523	Bearing Spacer
4	2	5522	Bearing
5	4	BOLT244	M8 x 35 Cap HD Skt Screw

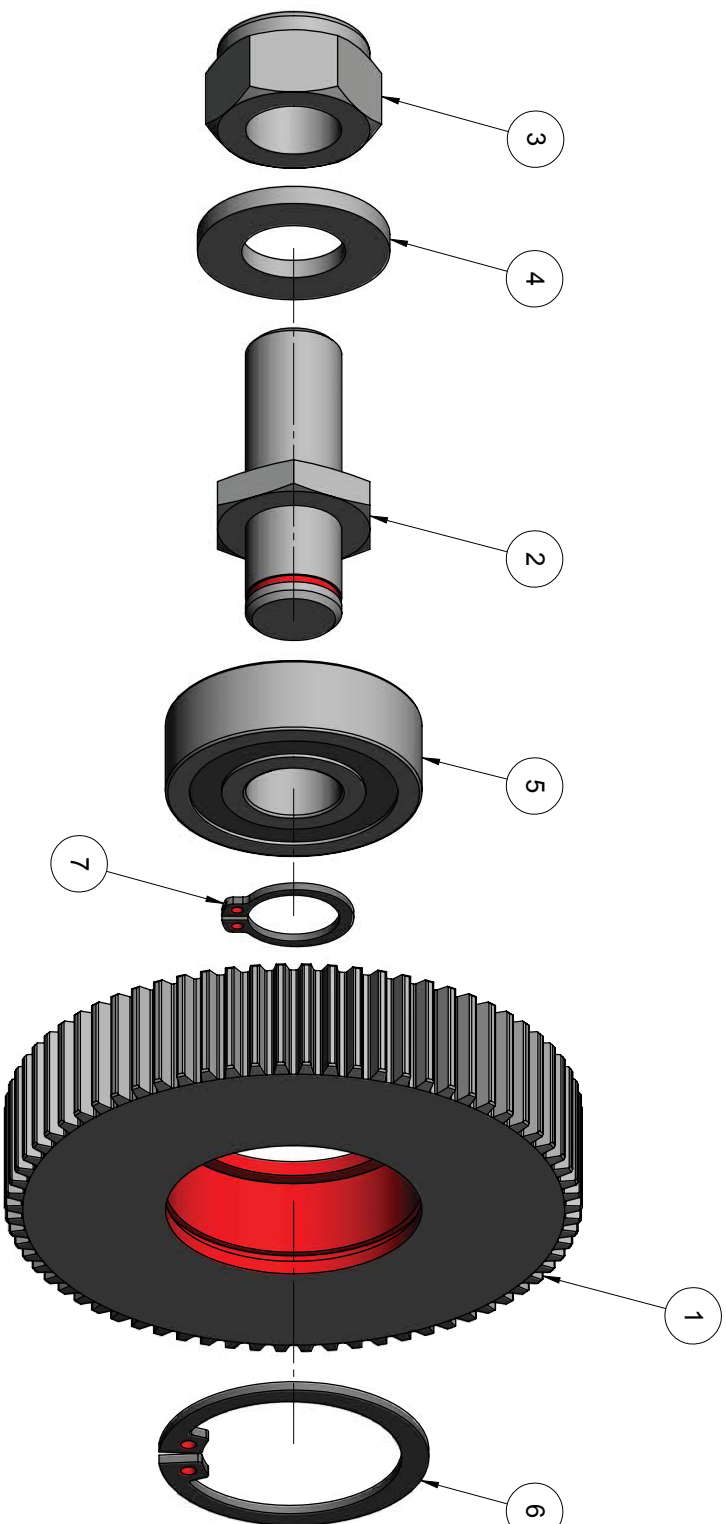

REVISIONS			
REV.	DESCRIPTION	DATE	APPROVED
1	INITIAL RELEASE	29/10/2013	BJ

ALL DIMENSIONS IN MM UNLESS OTHERWISE STATED GENERAL TOLERANCE ±0.5MM UNLESS OTHERWISE STATED		SPE International Ltd Honeyholes Lane, Dunholme, Lincolnshire, LN2 3SU, England	
THIRD ANGLE		TITLE: DFG-460 Intermediate Gear Assembly	
FINISH		MATERIAL	
DRAWING No. DFG-460-0067-1		DRAWN BY: GDC SCALE: NTS DATE: 17/10/2013	
QTY: -		A3	

Remove Sharp Edges & Corners
 All Machined Surfaces To Be Square & Parallel

Tei: +44 (0) 1673 860709/860330
 Fax: +44 (0) 1673 861119
 Web Site: <http://www.spe-int.com>
 E-mail: info@spe-int.com



THIS DOCUMENT IS PRIVATE AND CONFIDENTIAL AND THE PROPERTY OF SPE INTERNATIONAL LTD. IT MUST NOT BE COPIED OR SUBMITTED TO ANY THIRD PARTY WITHOUT THE CONSENT OF SPE INTERNATIONAL LTD.



DFG460-4
Operating Manual

INTERMEDIATE GEAR ASSEMBLY

ITEM	QTY	PART NUMBER	DESCRIPTION
1	3	5536	Idler Gear
2	3	5534	Idler Post
3	3	NUT046	M13 Nyloc Nut
4	3	WASHER006	M12 Flat Washer
5	3	5535	Bearing
6	3	5537	Circlip (Gear)
7	3	5538	Circlip (Post)

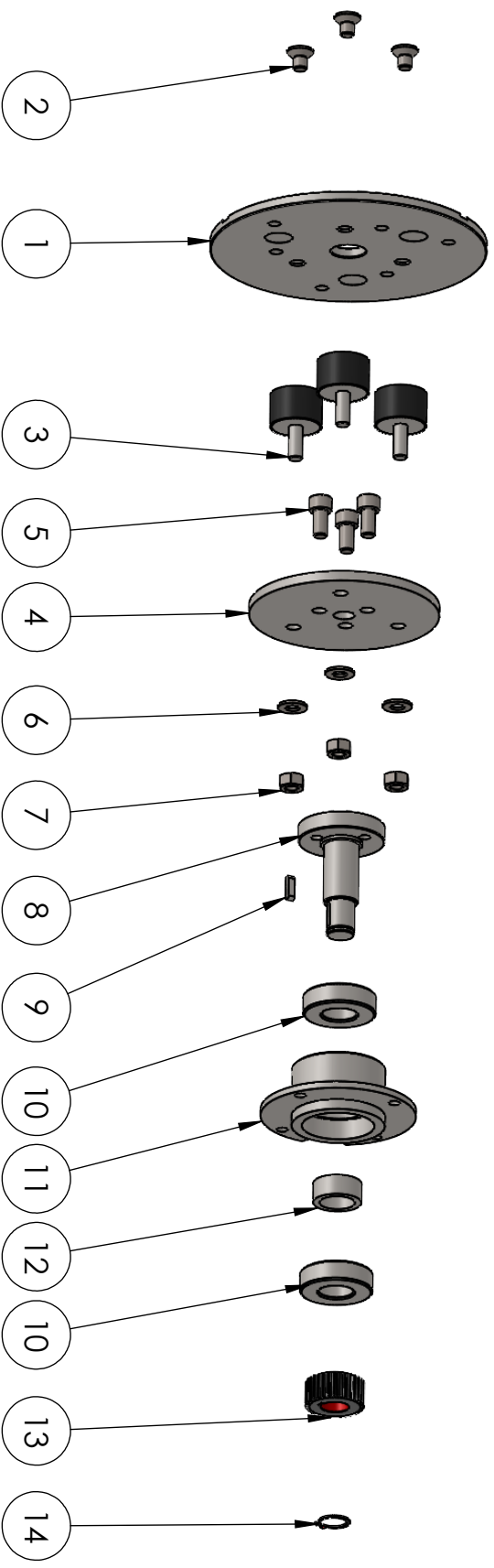

ALL DIMENSIONS
IN MM UNLESS
OTHERWISE STATED

GENERAL TOLERANCE
±0.5MM UNLESS
OTHERWISE STATED

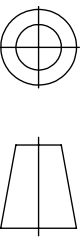

THIRD ANGLE



SPE International Ltd
Honeyholes Lane,
Dunholme,
Lincolnshire,
LN2 3SU,
England

Tel: +44 (0) 1673 860709
Fax: +44 (0) 1673 861119
E-mail: sales@spe-int.com
www.bartellglobal.com/spe



THIS DOCUMENT IS PRIVATE AND
CONFIDENTIAL AND THE PROPERTY
OF SPE INTERNATIONAL LTD.
IT MUST NOT BE COPIED OR
SUBMITTED TO ANY THIRD PARTY
WITHOUT THE CONSENT OF SPE
INTERNATIONAL LTD.

TITLE		QTY	
DFG-460 Driven Gear Assembly		3	
FINISH	MATERIAL	DRAWN BY	MA
		WEIGHT	
DRAWING No.	PART No.	DATE	REV
1	DFG-460-0068-1	21/09/2021	1
			SCALE
			1:4

ITEM NO.	PART NUMBER	DESCRIPTION	QTY.
1	5634	T-Mag Adaptor Plate	3
2	Bolt 145	M8X12 CSK SKT Screw	9
3	5532	Rubber Coupling	9
4	5531	DFG460 Driven Plate	3
5	Bolt 246	M8X16 CAP HD SKT SCREW	9
6	Spring Washer	M8 Spring Washer	9
7	NUT 044	M8 Nyloc Nut	9
8	5528	Driven Shaft	3
9	9113A	Height Screw Key	3
10	2213	Bearing	6
11	5526	Bearing Housing	3
12	5527	DFG460 Bearing Spacer	3
13	5529	DFG460 Driven Gear 32T	3
14	5530	DFG460 Shaft Circlip	3



DFG460-4
Operating Manual

ELECTRICAL COMPONENTS

QTY	PART NUMBER	DESCRIPTION
1	SP030317	Panel & Back Plate
1	5557	Frequency Inverter
1	SPVCCF2	Isolator 40 Amp
1	SPGV2ME20	Breaker/Overload
1	SPLC1D18M7	Contactor
1	SPLADS2	Delay Timer
1	SPZB4BS54	Emergency Stop Button
1	SPZB4BZ102	Stop Switch
1	SPZBY9330	Emergency Stop Legend
1	SPZB4BV4	Panel Lamp
1	SPZB4BV04	Lens
1	SPZB4BVM3	Green LED
1	SPZBE101	N/O Contact
1	SPZB4BW333	Green Lens Start Button
1	11124	Speed Control Knob Kit
2	SP541-2931	1 Amp Fuse
2	FUSE-ASK1	Fuse End Holder
1	FUSE-EW35	Fuse End Stop
1	SP410-409	16Amp 4Pin Panel Socket
4	9245	Rubber Mount
2	SPCG/LNM20	Cable Gland
5	7562	2.5mm ² Cable (mtr)
1	SP7302	220v 16Amp Schuko Trailing Plug



DFG460-4 Operating Manual

SPECIFICATION SHEET

Type	DFG 460 Electric
Part number	DFG460-4
Power output	2.2kw
Voltage	220v
Cycles	50
Head speed r.p.m.	0-231 variable
Engine/motor speed r.p.m.	0-1420
Machine dimensions (mm)	
Length	1040
Width	470
Height	1080
Weight (kg)	124



DFG460-4 Operating Manual

WARRANTY

The standard warranty period of this equipment is **12 months** from the despatch date in accordance with the company Conditions of Sale (copy attached).

<i>Warranty start date:</i>	As despatch date
<i>Model:</i>	DFG 460-4
<i>Serial no:</i>	
<i>Customer name:</i>	
<i>Customer Address:</i>	

<i>Manufacturer:</i>	SPE International Ltd
	Honeyholes Lane
	Dunholme
	Lincoln
	LN2 3SU
	England
<i>telephone:</i>	+44 (0) 1673 860709
<i>fax:</i>	+44 (0) 1673 861119
<i>Email:</i>	sales@spe-int.com
<i>Web site:</i>	www.spe-int.com

<i>Distributor:</i>



DFG460-4
Operating Manual

DECLARATION OF CONFORMITY

WE
SPE INTERNATIONAL LTD

OF
Honeyholes Lane
Dunholme
Lincoln
LN2 3SU

DECLARE that under our sole responsibility for the supply/manufacture of the product

(Description/name) **DFG 460 Floor Grinder**

(Model/type) **DFG 460-4**

to which this declaration relates is in conformity with the following standards and other normative documents following the provisions of Directive 2006/42/EC.

A handwritten signature in black ink, appearing to read 'B. Jacklin', is positioned above the printed name and title.

.....
Brian Jacklin – Technical Manager
SPE INTERNATIONAL LTD



CONDITIONS OF SALE

DFG460-4

Operating Manual

The quotation overleaf and any order placed following such quotation are subject to the following conditions of sale in which SPE International Limited is referred to as the "Company".

1. **Validity of quotation**
No order received from a customer by the Company shall constitute a contract until accepted in writing by the Company.
2. **Prices**
Prices quoted by the Company are firm for 30 days only or until previously withdrawn. Unless otherwise stated all prices are exclusive of any applicable Value Added Tax for which the customer shall be additionally liable to the Company.
3. **Delivery**
Delivery periods and dates are given in good faith but are not the subject of any warranty or condition and time shall not be of the essence of the contract in these respects. No liability will attach to the Company if delivery periods or dates are not met for any reason whatsoever.
4. **Payment**
Save as may otherwise be agreed in writing the customer shall pay the price in full on or before the estimated delivery date whereupon the Company shall raise a receipted invoice. Each invoice includes an Overdue Account Levy of 5% of the total invoice value inclusive of VAT. Subject to payment in full being made on or before the due date a sum equal to the Overdue Account Levy shall be credited to the customers account with the Company. Until such time as payment in full has been made the Company shall be under no obligation to allow or effect of any goods to the customer.
5. **Warranty**
The Company warrants that all goods supplied by it will correspond to their specifications and will be free from defects in materials or workmanship for a period of 12 months from the date of delivery. The Company's obligation in the event of a breach of this warranty is limited to the repair or replacement of any defective goods which shall be returned at the cost and expense of the customer to the Company. This warranty is given in lieu of all the other warranty or conditions expressed or implied (whether by statute or otherwise) and is subject to the following conditions:-
 - 5.1 Claims must be notified in writing to the Company within seven days from the date of delivery or (where the defect is not apparent on reasonable inspection) as soon as practicable after discovery of the defect.
 - 5.2 The Company shall be under no liability in respect of any defect in the goods arising from any drawing, design or specification supplied by the customer.
 - 5.3 The Company shall be under no liability if the defect or failure in the reasonable opinion of the Company arises from wilful damage or misuse, negligence by the customer or any third party. Failure to follow the Company instructions, usage of non-recommended parts and materials, alteration or repair of the goods without the prior approval of the Company or non-recommended maintenance.
 - 5.4 The Company shall be under no liability if the price for the goods has not been paid by the due date for payment.
 - 5.5 The above warranty does not extend to:-
 - 5.5.1 Parts, materials or equipment not manufactured by the company in respect of which the customer shall be entitled only to the benefit of any such warranty or guarantee as is given by the manufacturer to the Company.
 - 5.5.2 Any component part of the goods or associated parts coming into contact with abrasive elements or dust within surface Preparation equipment.
 - 5.5.3 Fair wear and tear of moving parts within the goods.
 - 5.6 Except in the case of death or personal injury caused by the Company negligence, the Company shall not be liable for any consequential loss or damage (whether for loss of profit or otherwise) or other claims for consequential compensation.
6. **Carriage**
Packing, carriage and insurance charges in respect of delivery of the goods to the customer will be charged to the customer at cost to the company.
7. **Damage in Transit**
The company does not accept any liability for loss or damage to the goods while in transit to the customer.
8. **Risk**
The risk in the goods shall pass to the customer on delivery to the customer or (if earlier) when possession of the goods is taken by a carrier for delivery to the customer.
9. **Force Majeure**
The Company shall not be liable to the customer or be deemed to be in breach of any contract with the customer by reason of any delay in performing or any failure to perform any obligation of the Company obligation in relation to the goods if the delay or failure was due to force majeure or to any other cause beyond the Company's reasonable control.
10. **Reservation of Title**
The goods sold under these conditions shall remain the absolute property of the Company and legal title in the goods shall remain vested in the Company until payment in full of all amounts invoiced or due to the Company in respect of the goods. If the customer shall enter into liquidation have a winding up order made against it or have a Liquidator, receiver, administrator or administrator receiver shall be appointed over its assets, income or any part thereof before the property in the goods has passed in accordance with this condition the Company shall be entitled immediately after giving notice of its intention to repossess any goods to enter upon the premises of the customer with such transport as may be necessary and to repossess any goods to which it has title under this condition. No liquidator, receiver, administrator or administrative receiver of the customer shall have authority to sell goods to which the Company has title without the prior written consent of the Company.
11. **Insolvency of Customer**
If the customer being a body corporate, shall pass a resolution or suffer an order of the Court to be made for winding – up, or if a Receiver, Administrator or Administrative Receiver shall be appointed or, being an individual or partnership, shall suspend payment, propose or enter into any composition or arrangement with his or their creditors, or have a bankruptcy order made against him or them, then the Company shall have the right, without prejudice to any other contract with the customer, not to proceed further with the contract and shall be entitled to charge for work already carried out (whether completed or not) and for goods and materials already purchased for the customer such charge to be an immediate debt due from the customer.
12. **Patent Rights, etc**
The acceptance of a quotation includes the recognition by the customer of the Company under any patents, trademarks, registered designs or other intellectual property rights relating to the goods and the customer undertakes that patent numbers, trademarks or other trade markings on goods supplied shall not be obliterated, altered or defaced.
13. **Applicable Law**
These conditions shall be governed by and construed in accordance with English law and parties acknowledge and accept the exclusive jurisdiction of the English Courts.