



# OWNER'S MANUAL

## POWER SPRAYER

S151, S201



Page Intentionally Left Blank

[www.BartellGlobal.com](http://www.BartellGlobal.com)

**CANADA**

170 Traders Blvd E  
Mississauga, Ontario L4Z 1W7  
TEL (647) 953-4100 FAX (647) 953-4101

**KENTUCKY**

4701 Allmond Ave  
Louisville, Kentucky 40209  
TEL (425) 405-9100 FAX (425) 405-9101

**UK**

Honeyholes Lane  
Dunholme, Lincoln, UK LN2 3SU  
TEL 01673 860709 FAX 01673 861119

**NEW JERSEY**

200 Commerce Drive, Unit A  
Freehold, New Jersey 07728  
TEL (848) 225-8100 FAX (848) 225-8101

**ORIGINAL LANGUAGE OPERATING MANUAL FOR  
BARTELL RIDE-ON TROWELS**

© 2024 Bartell Global Inc.

No part of this work may be reproduced or transmitted in any form or by any means, electronic or mechanical, including photocopying and recording, or by any information storage or retrieval system without the prior written permission of Bartell Morrison Inc. unless such copying is permitted by federal copyright laws.

**ADDRESS INQUIRIES OR REFERENCE PERMISSIONS CARE OF:**

Bartell Global, 170 Traders Blvd E., Mississauga, Ontario, Canada, L4Z 1W7

REV.	DATE	DESCRIPTION	APPROVED BY:
01	01/22	New Format	AN
02	01/24	New Logos	AN

## SAFETY PRECAUTIONS



### **DANGER** **EXPLOSION HAZARD**

Never operate the machine in an explosive atmosphere, near combustible materials, or where ventilation does not clear exhaust fumes.



### **WARNING** **BURN HAZARD**

Never come into contact with the engine or muffler when engine is operating or shortly after it is turned off. Serious burns may occur.



### **CAUTION** **MOVING PARTS**

Before starting the machine, ensure that all guards and safety devices are in place and functioning properly.

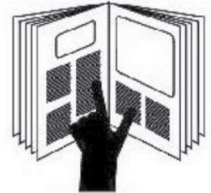

### **ATTENTION** **READ OWNER'S MANUAL**

Read and understand owner's manual before using this machine. Failure to follow operating instructions could result in serious injury or death.

## **TABLE OF CONTENTS**

<b><u>QUALITY ASSURANCE/ MACHINE BREAK IN</u></b>	<b>5</b>
<b><u>WARRANTY INFORMATION</u></b>	<b>5</b>
<b><u>SPECIFICATIONS</u></b>	<b>6</b>
<b><u>INTRODUCTION</u></b>	<b>6</b>
○ 1. MORRISON POWER SPRAYER	6
○ 2. OPTIONS	7
○ 3. DIMENSIONS	7
○ 4. SPRAYER MAIN COMPONENTS	8
<b><u>SAFETY INSTRUCTIONS</u></b>	<b>9</b>
○ 1. READING OPERATING INSTRUCTIONS	9
○ 2. SAFETY RULES	9
<b><u>SPRAYER ASSEMBLY</u></b>	<b>11</b>
<b><u>SPRAYER OPERATING INSTRUCTIONS</u></b>	<b>12</b>
<b><u>OPERATING TIPS AND REMINDERS</u></b>	<b>14</b>
<b><u>PREVENTATIVE MAINTENANCE AND ROUTINE SERVICE PLAN</u></b>	<b>15</b>
○ ROUTINE SERVICE SCHEDULE	16
<b><u>CLEANING</u></b>	<b>17</b>

## **QUALITY ASSURANCE/ MACHINE BREAK IN**

The Power Sprayer is the product of extensive engineering development designed to give long life and unmatched performance. You can help ensure that your Power Sprayer will perform at top levels by observing a simple routine on first use. Consider that your new Power Sprayer is like a new car. Just as you would break in a new car to the road or any new machine to the job, you should start gradually and build up to full use. Learn what your machine can do and how it will respond. Refer to the engine manufacturer's manual for run-in times. Full throttle and control may be used after this time period, as allowed by material. This will serve to further break in the machine on your specific application, as well as provide you with additional practice using the machine.

We thank you for the confidence you have placed in us by purchasing a Power Sprayer and wish you many years of satisfied use.

## **WARRANTY INFORMATION**

Bartell Morrison Inc. agrees to furnish without charge, F.O.B. our plant, a replacement for any part or portion thereof, comprising the sprayer part of the Bartell Power Sprayer, consisting of the, pump, hose system, save and except for power units and/or bearings which prove upon our examination, to be defective in either material or workmanship within a period of twelve (12) months from date of purchase, provided that notice of such defective part or portion thereof is given to Bartell Morrison Inc. within the twelve month warranty period. No further or other guarantee or warranty expressed or implied in connection with the sale of the Power Sprayer is given and our sole liability consists in replacing defective parts or portions thereof. We shall not be responsible for any special, indirect or consequential damages arising in any manner whatsoever.

This guarantee is for the sole benefit of the original purchaser as end user. Our responsibility under this guarantee ends in the case the original purchaser transfers ownership of the Power Sprayer, makes any changes, or adds any parts or devices not of our manufacture to the Power Sprayer.

## SPECIFICATIONS

	<b>S151</b>	<b>S201</b>
<b>Engine</b>	Honda 3.2 HP (GX120) (2.4 kW)	
	B&S 3.5 HP (XR550) (2.6 kW)	
<b>Pressure</b>	40-120psi	
<b>Hose Lengths</b>	25' (7.6m)	
	50' (15.2m)	
	75' (22.8m)	
<b>Flow Rate</b>	8gal/minute (30L/min) OR .03-.05 gal/min (3.8 – 6.4 oz/min)	
<b>Weight</b>	120lbs (55kg)	
<b>Max Solids</b>	20%	40%

## Introduction

### **TO THE OPERATOR:**

**DO NOT OPERATE THE BARTELL MORRISON POWER SPRAYER UNLESS YOU HAVE READ AND STUDIED THIS MANUAL CAREFULLY. REMEMBER THAT YOU ARE THE KEY TO SAFETY. GOOD SAFETY PRACTICES NOT ONLY PROTECT YOU, BUT ALSO THOSE WORKING AROUND YOU. MAKE THIS MANUAL A WORKING PART OF YOUR SAFETY PROGRAM.**

For safe operation of the power sprayer, you must be a qualified and authorized operator. To be qualified, you must understand these written instructions, have training, including actual operation of the power sprayer and know the safety rules and regulations for your job site.

An operator should never use drugs, alcohol or any other substance which can change his/ her alertness or coordination.

This manual is compiled from information available and current at time of approval for printing. Bartell Morrison Inc. reserves the right to improve its products without giving prior notice or incurring any obligation.

### **1. Morrison Power Sprayer**

The Morrison Power Sprayer is ideal for spraying all types of curing compound on bridge decks, highways, floor slabs, drainage channels, etc, after finishing work is completed. Easily handles form oils, pigmented curing compounds, bond breakers, soaps and detergents, pest control liquids, and most liquid type material.

It is powered by a dependable Honda engine and comes with 25' (7.6m) of 3/8" (0.95cm) hose with an adjustable spray nozzle.

## 2. Options

Hose Lengths: 50' (15.2m), 75' (22.7m), 100' (30.5m)

Fan Spray Nozzle

Pistol Grip Handle

Hand Cart

Tow Cart

## 3. Dimensions

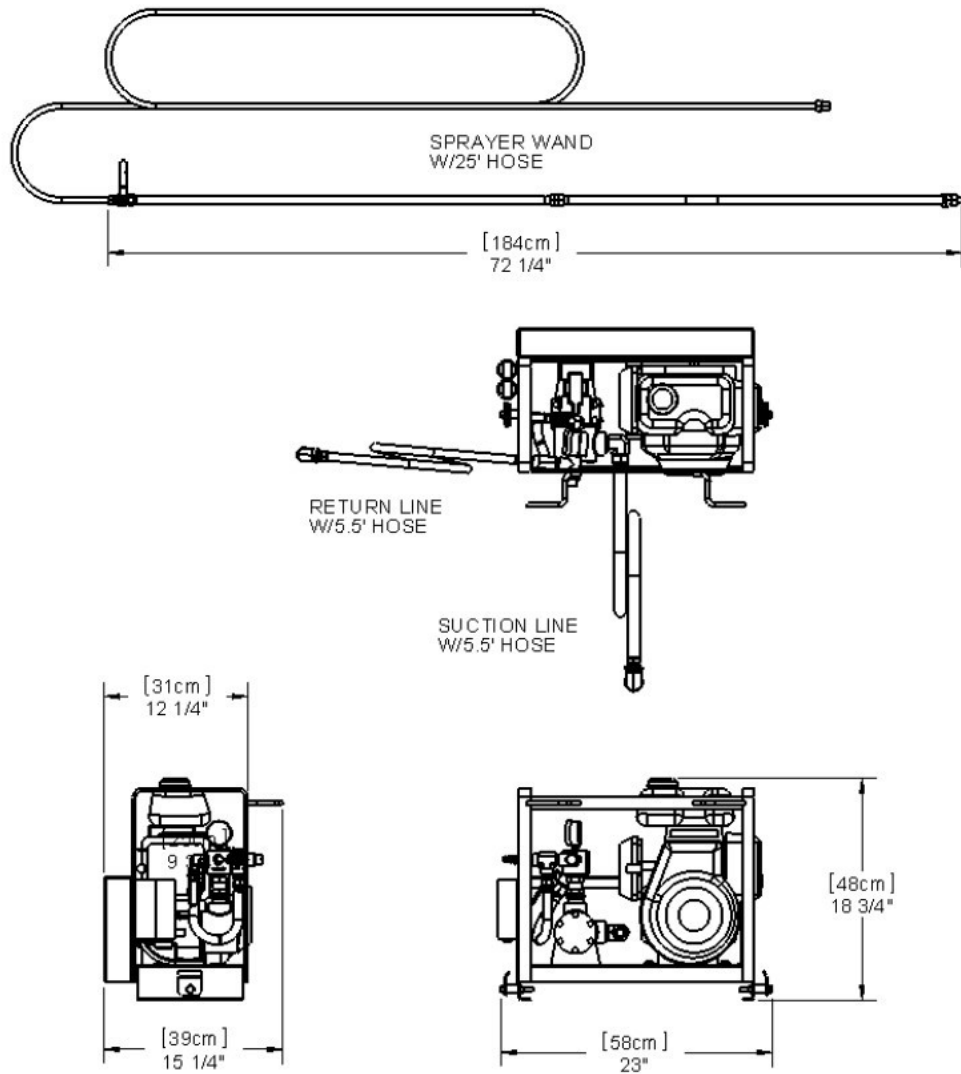

FIG. 1



#### 4. Sprayer Main Components

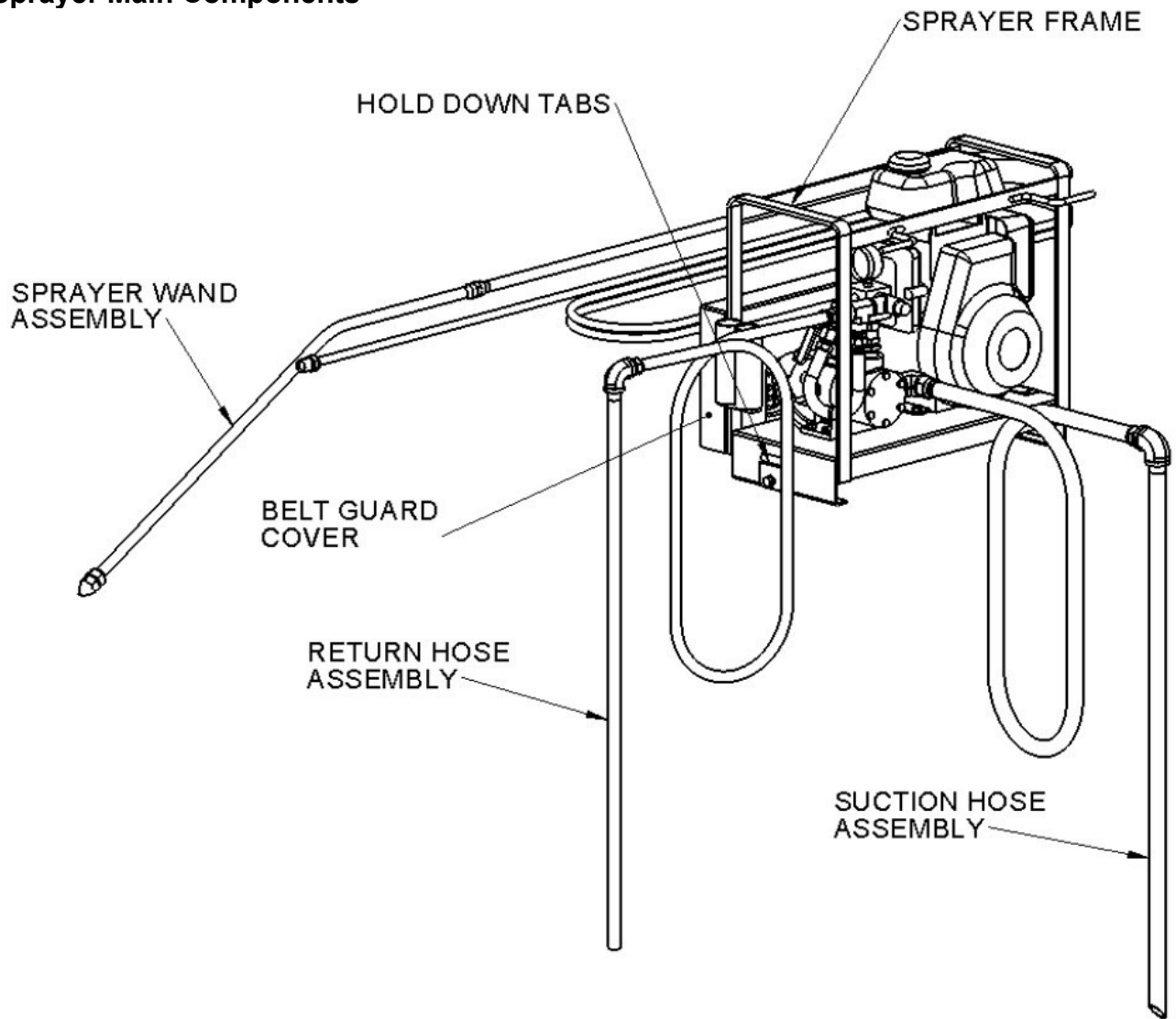

FIG. 2

## Safety Instructions

### 1. Reading Operating Instructions

Read and understand this entire manual before attempting to operate or service the equipment described herein. Failure to follow these operating instructions could result in serious injury or death. Store this manual with the machine and ensure it is apparent and available to any users.

### 2. Safety Rules

- The instructions provided in this manual are done so to ensure the operator's safety as well as that of other workers, the equipment, and the job site. Failure to abide by these guidelines can lead to serious personal injury and even death. The operator and any service personnel should read and understand the entire manual before working with or servicing the power sprayer.
- The operator's manual should be kept at all times in a place that is accessible to any persons working with the machine. Replacement manuals can be purchased from the equipment manufacturer or from your local dealer.
- Only use parts and attachments supplied or approved by your Bartell Morrison equipment dealer. The consequences of modifying the design of this equipment can include personal injury, equipment failure, and voiding your warranty. If you are unsure about a repair or an apparent malfunction, contact your Bartell Morrison dealer or the technical support line at the bottom of each page of this manual.
- NEVER use the power sprayer in an enclosed space with poor air flow, such as a basement or small room. The gasoline engine produces, among other things, toxic carbon monoxide gas. Without proper ventilation, this gas will build up and cause health effects such as organ damage and *death* to anyone in the vicinity.
- The operator should always be lucid and aware of his/her surroundings. NEVER operate the power sprayer while under the influence of drugs, alcohol, fatigue, sickness, hangover, extreme depression, anti-depressants, or emotional distraction.
- ALWAYS wear appropriate personal protective equipment while operating the Power Sprayer. This includes (but is not limited to) safety glasses, hearing protection, protective footwear, and heavy or padded gloves. Other safety gear may be job-site appropriate.
- NEVER leave the power sprayer unattended while running.
- Children and small animals should NEVER be present in the work area during operation of the power sprayer.
- ALWAYS check your power sprayer for loose or missing nuts and bolts before starting. Tighten any loose fasteners and replace missing or broken parts.
- Perform all routine maintenance as described within this manual. Failure to do so will void your warranty and will eventually result in premature equipment

failure.

- NEVER perform maintenance on a running piece of equipment. Shut down the engine and allow it to cool before servicing the power sprayer, including mechanical work or lubrication.
- ALWAYS replace missing, damaged, or unclear safety labels to ensure operator awareness and safety.
- NEVER operate the power sprayer with missing or damaged safety guards. Replace immediately with appropriate Morrison parts.
- NEVER put hands, feet, or other appendages inside the belt guard while the engine is running, even at idle or with protective clothing, as serious injury may result.
- NEVER wear loose fitting clothing or jewelry around rotating equipment such as the power sprayer as it may become entangled in the machinery, resulting in serious injury.
- ALWAYS refuel the power sprayer in a well-ventilated area, away from ignition sources such as sparks, flames, and lit cigarettes. Smoking while fuelling the equipment may result in explosion.
- Ensure the engine has cooled sufficiently before refueling to avoid igniting gasoline fumes.
- NEVER operate the power sprayer in explosive environments such as paint fumes, methane, natural gas, fine particulate, aerosol propellant, or solvent fumes.
- NEVER smoke near the power sprayer as stray gasoline fumes may ignite. Operating the power sprayer around an open flame may also result in explosion.
- ALWAYS shut down the engine and allow it to cool off before lifting or transporting the power sprayer.
- ALWAYS tie down the power sprayer when being transported in a truck or on a flatbed. Empty the fuel tank if transporting it over long distances.

## Sprayer Assembly

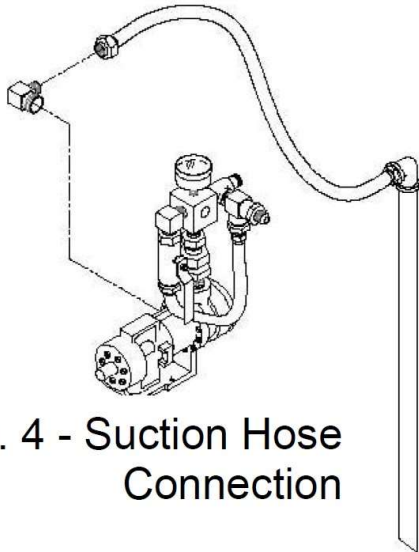

Fig. 4 - Suction Hose Connection

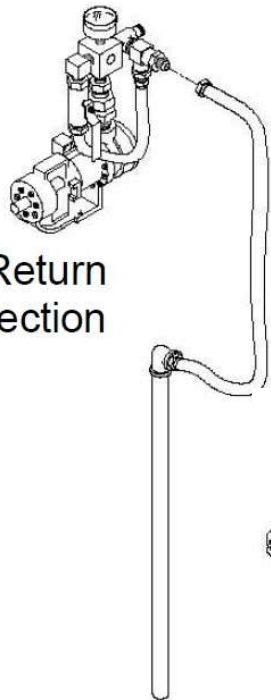

Fig. 5 - Return Hose Connection

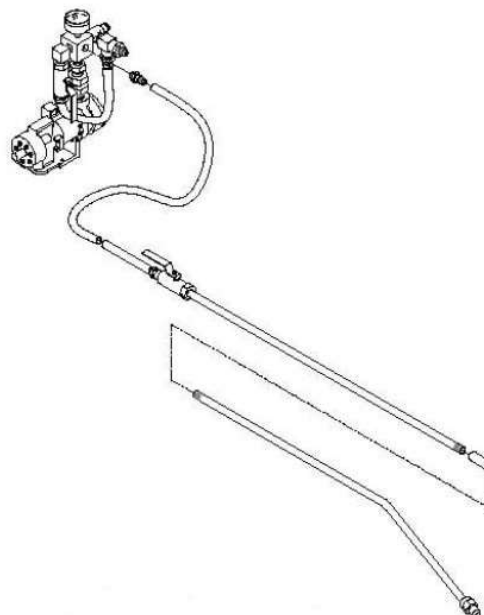

Fig. 6 - Spray Hose & Wand Connection

Your new Power Sprayer will arrive with everything you need in one shipping carton. Be sure to examine the content to be certain that the following items were included:

Return Hose: 1/2" hose/pipe

Suction Hose: 3/4" hose/pipe

Sprayer Wand Assembly: 25 ft. of 3/8" hose and (2) 3/8" pipes with a coupler

1. Remove the sprayer from the carton and place it on the curing drum you will be using. The sprayer should be mounted so that the openings on the drum are accessible on either side of the sprayer. Tighten the hold down tabs on the sprayer to the drum.

2. Attach the suction hose/pipe to the sprayer using the fitting mounted directly to the pump. (See Fig. 4)

3. Attach the fitting end of the return hose/pipe to the sprayer using the 1/2" connection on the spray block assembly. (See Fig. 5)

4. Join the two sections of the sprayer wand together using the pipe coupling provided. (See Fig. 6)

5. Attach the spray hose to the last fitting on the sprayer block assembly. (See Fig. 6) You are now ready to begin operation of the sprayer.

## Sprayer Operating Instructions

Before starting engine, refer to the engine owner's manual, follow the engine manufacturer's instructions for proper starting procedures, and follow the steps below.

**CAUTION:** If the material you are working with has solids in it, these will settle to the bottom of the drum. You must agitate it thoroughly before attempting to spray the material. If you do not do this, the sprayer will become clogged and possibly damage the pump.

1. Insert the suction hose into the drum using the larger of the two access holes. We recommend using a support under the hose so that it will not reach the bottom of the drum where sediment can clog the suction hose.
2. Insert the return hose into the drum using the smaller of the two openings.
3. The sprayer has a bypass valve that allows the engine to be started without pressure building in the pump. Turn out counterclockwise the pressure relief to lowest setting and rotate the bypass valve handle to the downward position before starting the engine. This valve allows you to stir the curing material by circulating it directly through the pump.
4. Read the engine manufacturer's instructions carefully before starting the engine. **CHECK OIL!!**
5. Check the end of the suction hose to be certain it is immersed in the liquid but not in the sediment in the bottom of the drum.
6. With the bypass valve in the on, downward position, start the engine and allow it to run for 2-10 minutes. This aids in the mixing of the spray compound and assures greater pump efficiency and life. (See Fig. 6)

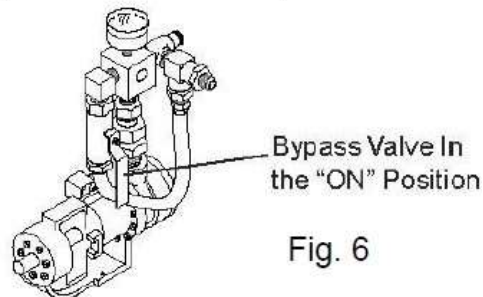

**NOTICE:** Some compounds have a tendency to foam when air is introduced. This foaming can cause erratic pump performance. Please do not insert spray nozzle into the drum in an attempt to stir the material! This will only cause more foam in the compound.

7. Be certain the spray wand is off before turning the bypass valve to the off position to pressurize the system.
8. Turn the bypass valve to the off position. You are now ready to spray.

9. Adjustments to the spray pattern can be made with the nozzle at the end of the spray wand. Turn the nozzle counterclockwise to narrow the spray pattern, and clockwise to broaden the spray pattern.

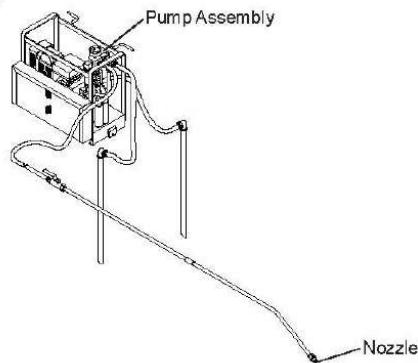

Fig. 7

10. The sprayer has an adjustable pressure relief valve (See Fig. 8) on the block assembly. You may need to vary the pressure according to the viscosity of the material you are using. Thinner liquids tend to need more pressure to assure a good coverage pattern. It is recommended to use a lower pressure setting for certain liquids, especially with higher solids, as high pressures can be problematic.

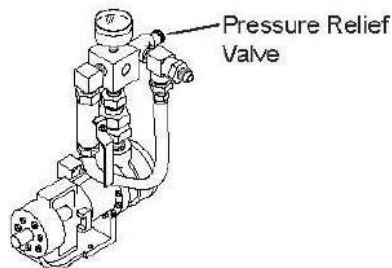

Fig. 8

**CAUTION: NEVER EXCEED 100 PSI (S151) or 150 PSI (S201)**

11. While not spraying, turn the bypass valve on to remove unnecessary pressure from the pump. Turning off the engine when not spraying will prolong the life of the pump.

12. The return hose may be used to check for any sediment remaining lodged at the bottom of the drum. If none is detected, the suction hose can be lowered completely into the drum. If sediment remains after several minutes of spraying, it may be necessary to remove the sprayer and stir the material manually.

## **Operating Tips and Reminders**

1. Always start the engine with the bypass valve in the on position to reduce system pressure and the pressure relief set to low.
2. Always stir the compound before attempting to operate the sprayer.
3. When not spraying, turn the bypass valve to the on position, or stop the engine. This will add several hours of life to your sprayer.
4. Follow manufacturer's directions and safety procedures in the use of materials used to clean the sprayer.
5. Periodically clean the spray nozzle, as materials tend to clog, causing poor spray performance.
6. Clean the sprayer after every use.
7. Flush after cleaning completely so that no solvents remain in the system.
8. Use care to avoid crimping or damaging hoses. Do not allow accumulations of compounds to build up on hoses.
9. NEVER directly spray nozzle in the direction of eyes or face.

## PREVENTATIVE MAINTENANCE AND ROUTINE SERVICE PLAN

This Bartell Power Sprayer has been assembled with care and will provide years of service. Preventative maintenance and routine service are essential to the long life of your Power Sprayer. Your dealer is interested in your new machine and has the desire to help you get the most value from it. After reading through this manual thoroughly, you will find that you can do some of the regular maintenance yourself. However, when in need of parts or major service be sure to see your Bartell dealer. For your convenience we have provided this space to record relevant data about your Power Sprayer. When in need of parts or service be prepared to provide your Power Sprayer serial number. Locate the serial number now and record in the space below.

Date Purchased:		Type of Machine:	
Dealer Name:		Model:	
Dealer Phone:		Serial Number:	

Replacement Parts Used				Maintenance Log:	
Part No.	Quantity	Cost	Date	Date	Operation



### Routine Service Schedule

Routine Service Intervals		Each Use	After 1.5 months or 50 hrs	Each 3 months or 100 hrs	Each 6 months or 200 hrs	Each 9 months or 300 hrs	Each 12 months or 400 hrs
<b>General Inspection</b>							
Guards	Check	○	○	○	○	○	○
Warning Stickers	Check		○	○	○	○	○
Test Run	Check - Operation		○	○	○	○	○
<b>Engine</b>							
Engine Oil	Check level	○	○	○	○	○	○
	Change		○		○		○
Air Cleaner	Check - Clean	○	○				
	Replace			○			
Sediment Cup	Clean			○	○	○	○
Spark Plug	Check - adjust			○	○		○
	Replace					○	
Idle Speed	Check - adjust					○	○
Valve Clearance	Check - adjust					○	
Combustion Chamber	Clean	After every 500 Hrs.					
Fuel Tank + Filter	Clean	Every 6 months or 100 Hrs.					
Fuel Tube	Check	Every 2 years (Replace if necessary)					
<b>Spray System</b>							
Pump and Hoses	Clean	○	○	○	○	○	○
Hoses	Check for punctures		○	○	○	○	○
	Replace if damaged						

## **Cleaning**

It is essential that the sprayer be cleaned after each use. Parts that fail due to improper cleaning will not be warranted. Use the following steps as a guide to proper cleaning and maintenance.

1. Place the suction hose into a container that has been filled with a solvent recommended by the compound manufacturer to clean spraying equipment after use.
2. Place the return hose in an empty container the same size, or larger than the one with the cleaning agent.
3. Turn the bypass valve to the on position and start the engine. Allow the cleaning agent to run through the pump for 2-3 minutes.
4. Turn the bypass valve to the off position and spray wand to the on position. Allow the wand to spray into the empty container for about 20 seconds. This procedure may need to be repeated several times to ensure that the pump and spray wand are clean.
5. Check the procedures for cleaning provided by the solvent manufacturer. Some cleaning solvents require that they be flushed out with water after they are used. If this is the case, we recommend that a small amount of form oil or diesel fuel be used **AFTER** using water. This will prevent the internal components of the pump from seizing, due to the formation of rust on the pump internals.
6. Disconnect all the hoses and allow all the liquid to drain from the lines.
7. As you begin your next spraying operation, spray a small amount of compound through the lines and into an empty container. This will clear any remaining water or solvent before it is mixed with the regular spraying compound.

Page Intentionally Left Blank

CONTRACTOR PROVEN EQUIPMENT SINCE 1946



170 Traders Blvd E  
Mississauga, ON L4Z 1W7  
Canada

4701 Allmond Avenue  
Louisville, KY 40209  
United States

200 Commerce Drive  
Freehold, NJ 07728  
United States

Honeyholes Lane  
Dunholme, Lincoln LN2 3SU  
United Kingdom

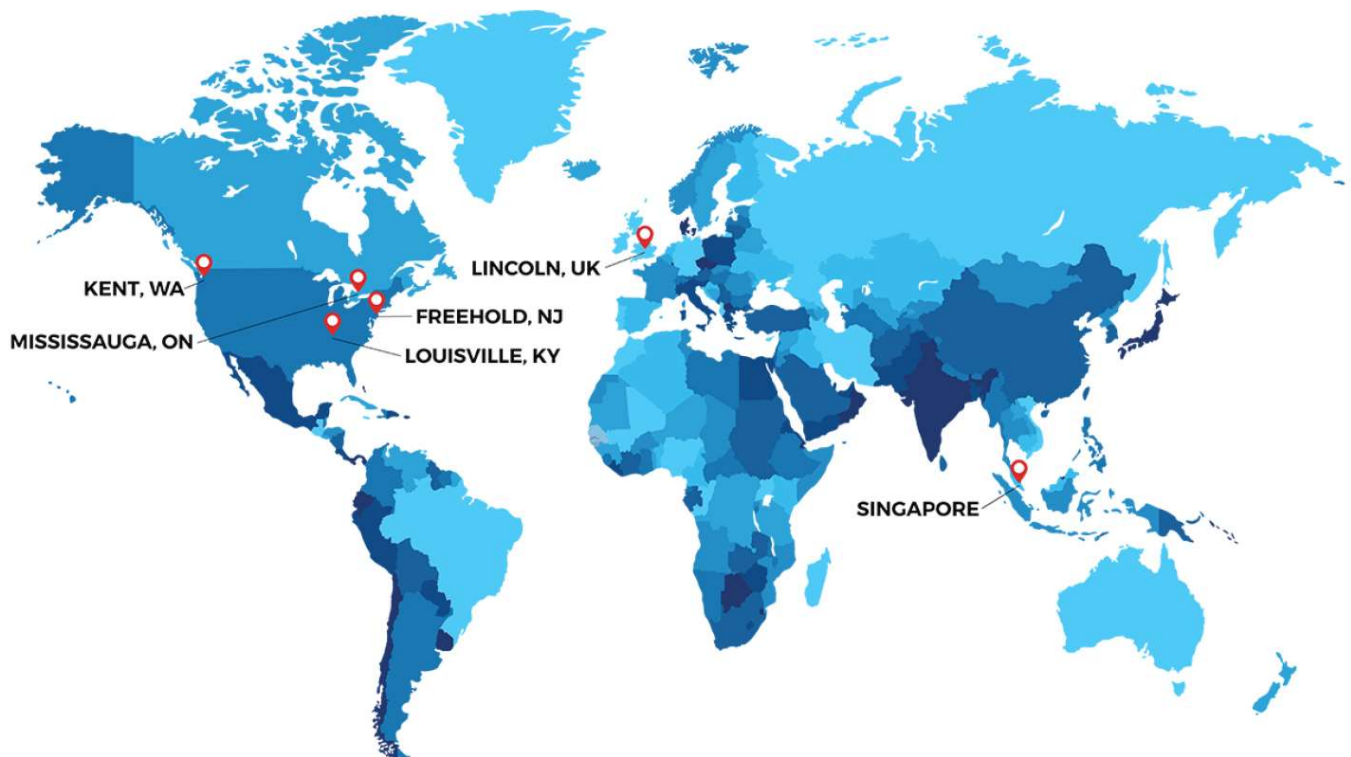

[BartellGlobal.com](http://BartellGlobal.com)