



**BARTELL
GLOBAL**

**OWNER'S
MANUAL**

RIDE-ON TROWELS

BXR836/836P/836H, BXR830/830P, Titan 78/88/96/96P



Page intentionally left blank.

www.BartellGlobal.com

CANADA

170 Traders Blvd E
Mississauga, Ontario L4Z 1W7
TEL (647) 953-4100 FAX (647) 953-4101

KENTUCKY

4701 Allmond Ave
Louisville, Kentucky 40209
TEL (425) 405-9100 FAX (425) 405-9101

UK

Honeyholes Lane
Dunholme, Lincoln, UK LN2 3SU
TEL 01673 860709 FAX 01673 861119

NEW JERSEY

200 Commerce Drive, Unit A
Freehold, New Jersey 07728
TEL (848) 225-8100 FAX (848) 225-8101

**ORIGINAL LANGUAGE OPERATING MANUAL FOR
BARTELL RIDE-ON TROWELS**

© 2022 Bartell Global Inc.

No part of this work may be reproduced or transmitted in any form or by any means, electronic or mechanical, including photocopying and recording, or by any information storage or retrieval system without the prior written permission of Bartell Morrison Inc. unless such copying is permitted by federal copyright laws.

ADDRESS INQUIRIES OR REFERENCE PERMISSIONS CARE OF:

Bartell Global, 170 Traders Blvd E., Mississauga, Ontario, Canada, L4Z 1W7

REV.	DATE	DESCRIPTION	APPROVED BY:
04	04/19	Added information for Titan 96 Propane	AN
05	10/19	Updated Address	AN
06	12/20	Added Information for BXR Propane	AN
07	04/21	Added Information for BXR830	AN
08	08/22	Removed TS machines, Added BXR836H	AN

SAFETY PRECAUTIONS

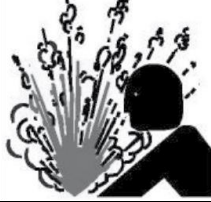

DANGER **EXPLOSION HAZARD**

Never operate the machine in an explosive atmosphere, near combustible materials, or where ventilation does not clear exhaust fumes.



WARNING **BURN HAZARD**

Never come into contact with the engine or muffler when engine is operating or shortly after it is turned off. Serious burns may occur.



WARNING **ROTATING HAZARD**

Never place hands or feet inside safety guard rings. Serious injury will result from contact with rotating blades.



CAUTION **MOVING PARTS**

Before starting the machine, ensure that all guards and safety devices are in place and functioning properly.



ATTENTION **READ OWNER'S MANUAL**

Read and understand owner's manual before using this machine. Failure to follow operating instructions could result in serious injury or death.

TABLE OF CONTENTS

<u>QUALITY ASSURANCE/MACHINE BREAK IN</u>	5
<u>WARRANTY INFORMATION</u>	6
<u>SPECIFICATIONS</u>	7
<u>PREVENTATIVE MAINTENANCE AND ROUTINE SERVICE PLAN</u>	9
○ ROUTINE SERVICE SCHEDULE	10
○ ROUTINE SERVICE INTERVALS	12
<u>SAFETY PRECAUTIONS</u>	13
<u>ASSEMBLY INSTRUCTIONS</u>	14
<u>OPERATING INSTRUCTIONS</u>	15
○ STARTING PROCEDURES - WARM TEMPERATURES	15
○ STARTING PROCEDURES - COLD TEMPERATURES	15
○ STOPPING PROCEDURE	15
○ STEERING (MECHANICAL AND HYDRAULIC)	15
○ FLOAT/TROWEL PITCH SETTING	16
○ BLADE SYNCHRONIZATION	16
○ TRANSPORTER USE	17
○ TITAN TRANSPORTER INSTRUCTIONS	18
<u>MAINTENANCE INSTRUCTIONS</u>	19
○ GENERAL	19
○ AIR CLEANER	19
○ SPARK PLUG	19
○ BELT CHANGE PROCEDURE	20
<u>LUBRICATION</u>	21
<u>TROWEL ARM ADJUSTMENT FIXTURE</u>	22
○ ADJUSTMENT PROCEDURE	22
○ TROWEL ARM ADJUSTMENT SCREW	23
<u>TROUBLESHOOTING</u>	24

QUALITY ASSURANCE/MACHINE BREAK IN

The Bartell Ride-on Trowel is the product of extensive engineering development designed to give long life and unmatched performance. Once machines are fully assembled, a run-in test is performed to ensure quality standards of the highest level. A series of operational tests are conducted on concrete, incorporating a phase of operations at 1/2 to 3/4 throttle and a final run phase at full throttle for a minimum of 20 minutes.

You can help ensure that your Ride-on will perform at top levels by following a simple routine on first use. Consider that your new Ride-on Trowel is like a new car. Just as you would break in a new car to the road or any new machine to the job, you should start gradually and build up to full use. Learn what your machine can do and how it will respond. Refer to the engine manufacturer's manual for run-in times. Full throttle and control may be used after this time period, as allowed by material. This will serve to further break in the machine on your specific application, as well as provide you with additional practice using the machine.

We thank you for the confidence you have placed in us by purchasing a Bartell Ride-on Trowel and wish you many years of satisfied use.

WARRANTY INFORMATION

All ride-on trowels sold by Bartell Morrison Inc. are warranted against defects in materials and/or workmanship; excluding normal wear on wearing components and components covered by a separate original manufacturer's warranty, for a period of 12 months from the date of sale to the original end user purchaser provided that certain conditions have been met.

Conditions:

1. The equipment serial number has been registered with Bartell Morrison Inc. or its approved dealers, distributors, representatives, or agents.
2. The equipment has been operated in an appropriate manner by qualified individuals.
3. The equipment has been properly maintained as per the instructions included in the Owner's Manual.
4. All claims for warranty must be filed on proper forms and include the serial number of the equipment along with proof of purchase.

Any evidence of failure to meet these conditions may result in a denial of the warranty claim. Consideration of warranty claims will be at the sole discretion of Bartell Morrison Inc., or its authorized dealers, distributors, representatives, or agents. Bartell Morrison Inc. may, at its discretion, request that the equipment to be considered for warranty be returned at the owner's expense to an authorized repair facility for inspection. Under this warranty we may, at our discretion, repair or replace a part or the whole of the defective component or equipment. Our Warranty coverage is limited to the cost to repair or replace the defective portion of the equipment and a reasonable (as determined by Bartell Morrison Inc.) amount of labour to conduct the repair or replacement. Under no circumstances shall Bartell Morrison Inc. be liable for any additional or exceptional costs beyond the cost to repair or replace the defective portion of the equipment. Bartell Morrison Inc. shall not be held accountable for; costs associated with travel to inspect or repair defective equipment, costs for transporting defective equipment to or from an authorized repair facility, costs incurred to repair or replace the defective equipment at any facility other than one authorized by Bartell Morrison Inc., or ancillary damage caused by or because of the defective equipment. Under no circumstances shall equipment be returned to Bartell Morrison Inc. or its authorized dealers, distributors, representatives, or agents without the approval of Bartell Morrison Inc. as evidenced by a Returned Goods Number. To obtain a Returned Goods Number contact the factory or your authorized dealer, distributor, representative or agent. This warranty is for the sole benefit of the original end user purchaser and is not transferable to any other company or person.

SPECIFICATIONS

	BXR836	BXR836 Propane	BXR836 Hydraulic	BXR830	BXR830 Propane
Engine Options	Honda 22hp	Vanguard 21hp	Honda 22hp	Honda 22hp	Vanguard 21hp
Fuel Type	Gas/Petrol	Propane	Gas/Petrol	Gas/Petrol	Propane
Length	73" (186 cm)	73" (186 cm)	73" (186 cm)	67.5" (171 cm)	67.5" (171 cm)
Width	40" (102 cm)	40" (102 cm)	40" (102 cm)	30" (76 cm)	30" (76 cm)
Path	71" (180 cm)	71" (180 cm)	71" (180 cm)	67.5" (171 cm)	67.5" (171 cm)
Height	41" (104 cm)	41" (104 cm)		41" (104 cm)	41" (104 cm)
Weight	492lbs (223.6 kg)	648lbs (294 kg)		635lbs (288 kg)	640lbs (290 kg)
Trowel Coverage	14.5 sq. ft. (1.34 sq. m)	14.5 sq. ft. (1.34 sq. m)	14.5 sq. ft. (1.34 sq. m)	10 sq. ft. (0.9 sq. m)	10 sq. ft. (0.9 sq. m)
Travel Speed	Up to 380ft/min (115m/min)	Up to 380ft/min (115m/min)	Up to 380ft/min (115m/min)	Up to 380ft/min (115m/min)	Up to 380ft/min (115m/min)
Dual Rotor Speeds	145 rpm	130 rpm	145 rpm	145 RPM	130 RPM
Float Blade Size	10" x 14" (25 x 35.6 cm)	10" x 14" (25 x 35.6 cm)	10" x 14" (25 x 35.6 cm)	N/A	N/A
Finish Blade Size	6" x 14" (15 x 35.6 cm)	6" x 14" (15 x 35.6 cm)	6" x 14" (15 x 35.6 cm)	6" x 10.5" (15 x 27 cm)	6" x 10.5" (15 x 27 cm)
Combo Blade Size	8" x 14" (20 x 35.6 cm)	8" x 14" (20 x 35.6 cm)	8" x 14" (20 x 35.6 cm)	N/A	N/A
Pan Float Size	36.5" (92.7 cm)	36.5" (92.7 cm)	36.5" (92.7 cm)	30" (76.2 cm)	30" (76.2 cm)
Electric Start	Yes	Yes	Yes	Yes	Yes
Electrical System	12 Volt	12 Volt	12 Volt	12 Volt	12 Volt
Charging System	16 Amps	16 Amp	16 Amp	16 Amps	16 Amp
Battery	12 Volt	12 Volt	12 Volt	12 Volt	12 Volt
Safety Switch	Yes	Yes	Yes	Yes	Yes
Fuel Capacity (approx.)	3 Gal. (12.5 mL)	20 Lb. Propane Tank 4.7 Gal. (17.79L)	3 Gal. (12.5 mL)	3 Gal. (12.5 mL)	20 Lb. Propane Tank 4.7 Gal. (17.79L)
Running Time (approx.)	2.5 hours	2.5 Hours	2.5 hours	2.5 Hours	2.5 Hours
Steering Levers	Twin Sticks	Twin Sticks	Hydraulic Joy Sticks	Twin Sticks	Twin Sticks
Variable Speed Clutch	No	No	No	No	No
"U" Joint Drive Coupling	Yes	Yes	Yes	Yes	Yes
Single Belt Drive	Yes	Yes	Yes	Yes	Yes
Standard Features	Seat Adjuster Hour Meter 50W Light Package Lifting Hooks Spray System	Seat Adjuster Hour Meter 50W Light Package Lifting Hooks Spray System Catalytic Muffler	Seat Adjuster Hour Meter 50W Light Package Lifting Hooks Spray System	Seat Adjuster Hour Meter 50W Light Package Lifting Hooks Spray System	Seat Adjuster Hour Meter 50W Light Package Lifting Hooks Spray System Catalytic Muffler
Options	Catalytic Muffler Transporter Combo Blades Pan Float Discs	Transporter Combo Blades Pan Float Discs	Catalytic Muffler Transporter Combo Blades Pan Float Discs	Catalytic Muffler Transporter Pan Float Discs	Transporter Splash Guard Pan Float Discs

	Titan 78	Titan 88	Titan 96	Titan 96 Propane
Engine Options	Kohler 23.5hp Kohler 25hp Kohler 26.5hp (EFI)	Kohler 23.5hp Kohler 25hp Kohler 26.5hp (EFI)	Vanguard 35hp Vanguard 37hp (EFI)	Vanguard 35hp Propane
Length	76 1/4" (194 cm)	88" (224 cm)	96" (244 cm)	96" (244 cm)
Width	40-1/2" (103 cm)	48" (122 cm)	48" (122 cm)	48" (122 cm)
Path	73 3/4" (187 cm)	85" (216 cm)	93" (236 cm)	93" (236 cm)
Height (seat folded down)	52" (132cm)	52" (132cm)	52" (132cm)	52" (132cm)
Weight	Up to 885lbs (402 kg)	Up to 935lbs (425 kg)	Up to 940lbs (427 kg)	Up to 940lbs (427 kg)
Trowel Coverage	18 sq. ft. (1.7 sq. m)	27 sq. ft. (2.5 sq. m)	29 sq. ft. (2.7 sq. m)	29 sq. ft. (2.7 sq. m)
Travel Speed	Up to 400ft/min (122m/min)	Up to 380ft/min (116m/min)	Up to 380 ft/min (116m/min)	Up to 380 ft/min (116m/min)
Dual Rotor Speeds	180 rpm	180 rpm	180 rpm	180 rpm
Float Blade Size	10"x14" (25x35.6 cm)	10"x18" (25x46 cm)	10"x18" (25x46 cm)	10"x18" (25x46 cm)
Finish Blade Size	6"x14" (15x35.6 cm)	6"x18" (15x46 cm)	6"x18" (15x46 cm)	6"x18" (15x46 cm)
Combo Blade Size	8"x14" (20x35.6 cm)	8"x18" (20x46 cm)	8"x18" (20x46 cm)	8"x18" (20x46 cm)
Pan Float Size	37" (94 cm)	N/A	46" (118 cm)	46" (118 cm)
Electric Start	Yes	Yes	Yes	Yes
Electrical System	12 Volt	12 Volt	12 Volt	12 Volt
Charging System	25 Amps	15 to 25 Amps	15 or 25 Amps	15 or 25 Amps
Battery	12 Volt	12 Volt	12 Volt	12 Volt
Safety Switch	Yes (in seat)	Yes (in seat)	Yes (in seat)	Yes (in seat)
Fuel Capacity	6 Gal. (22.71L)	6 Gal. (22.71L)	6 Gal. (22.71L)	20 Lb. Propane Tank 4.7 Gal. (17.79L)
Steering Levers	Twin Sticks	Twin Sticks	Twin Sticks	Twin Sticks
Variable Speed Clutch	Yes	Yes	Yes	Yes
"U" Joint Drive Coupling	Yes	Yes	Yes	Yes
Single Belt Drive	Yes	Yes	Yes	Yes
Standard Features	Lifting Hooks Seat Adjuster LED Lights Dual USB Charger		Dual Position Steering Hour Meter with Tach Hand Trowel Holder	
Options	Catalytic Muffler Retardant Sprayer Pan Float Discs		Transporter Combo Blades (not 88) Weight Package (18 to 216lbs) (8 to 96kg)	

ROUTINE SERVICE SCHEDULE

Routine Service Intervals		Each Use	After 1.5 months or 50 hrs	Each 3 months or 100 hrs	Each 6 months or 200 hrs	Each 9 months or 300 hrs	Each 12 months or 400 hrs
General Inspection							
Operation of lights	Check		○	○	○	○	○
Battery	Check and clean			○	○	○	○
	Recharge			○	○	○	○
	Replace						2 yrs
Guards	Check	○	○	○	○	○	○
Warning Stickers	Check		○	○	○	○	○
Test Run	Check Operation		○	○	○	○	○
Controls							
Safety switch operation	Check	○	○	○	○	○	○
Throttle pedal operation	Check	○	○	○	○	○	○
Steering Linkages	Check	○	○	○	○	○	○
	Lubricate		○	○	○	○	○
	Replace						As req'd
Hydraulic Fluid	Check	○	○	○	○	○	○
	Replace				○		○
Pitch Control Levers	Check	○	○	○	○	○	○
	Lubricate		○	○	○	○	○
Engine:							
Fuel Lines & Clamps	Check		○	○	○	○	○
	Replace						2 yrs
Engine oil	Check level	○	○	○	○	○	○
	Change		○		○		○
Engine oil filter	Replace				○		○
Oil Cooler	Clean			○	○	○	○
Cooling fins	Clean		○	○	○	○	○
Air Cleaner	Check-clean	○	○	○	○	○	○
	Replace						○
Air Intake Line	Check				○		
	Replace						2 yrs
Valve Clearance	Check-adjust				○		○
Fuel Filter	Check and clean			○	○	○	○
	Replace				○		
Fuel Tank	Clean						500 hrs
Fuel Injection Nozzles	Check pressure						500 hrs
Fuel Injection Timer	Check						500 hrs
Injection Pump	Check						500 hrs
Engine Wiring	Check						○
Coolant	Check	○					
	Change						○

Routine Service Intervals		Each Use	After 1.5 months or 50 hrs	Each 3 months or 100 hrs	Each 6 months or 200 hrs	Each 9 months or 300 hrs	Each 12 months or 400 hrs
Drive Train:							
Bearings	Lubricate	○	○	○	○	○	○
Universal Couplings	Lubricate			○	○	○	○
Belt Tension/ Condition	Check	○	○	○	○	○	○
Clutch/ Pulley Operation	Check	○	○	○	○	○	○
LH spider plate assembly	Check	○		○	○	○	○
	Lubricate	○	○	○	○	○	○
RH spider plate assembly	Check	○		○	○	○	○
	Lubricate	○	○	○	○	○	○
Gearboxes:							
LH Gearbox oil	Check level	○	○	○	○	○	○
	Change				○		○
RH Gearbox oil	Check level	○	○	○	○	○	○
	Change				○		○
Gearbox breathers	Check operation			○	○	○	○
Water Retardant Spray:							
Water pump operation	Check	○	○	○	○	○	○
Spray Nozzles	Clean	○					
Retardant Fluid	Check levels	○					
Hydraulic System (If applicable):							
Hoses/Connections	Check for leaks	○	○	○	○	○	○
Oil Tank	Check Level	○			○		○
	Change						○
Filter	Change				○		○

ROUTINE SERVICE INTERVALS

Due to the nature and environment of use, power trowels are exposed to severe operating conditions.

Some general maintenance guidelines will extend the useful life of your trowel:

- The initial service for your power trowel should be performed after 25 hours of use, at which time your mechanic (or authorized repair shop) should complete all of the recommended checks in the schedule above. The previous chart is handy for keeping a record of the maintenance performed and the parts used for servicing your trowel.
- Regular service according to the schedule above will prolong the life of the power trowel and prevent expensive repairs.
- **Keeping your power trowel clean and free from concrete residue is the single most important regular maintenance operation**, over and above the checks in the service schedule above. Components such as oil seals, belts, drive line parts and bearings are prone to premature wear from exposure to concrete residue. Using a spray-on release agent on your power trowel before each use will make clean-up after use easy and extend the time between the replacements of most of the wearing components of the machine.
- After each use, your power trowel should be cleaned to remove any concrete residue from the undercarriage and surrounding components. Use of a power washer will make clean up quick and easy, especially if a release agent was applied prior to use.
- In the Service Schedule above, items that should be checked, replaced or adjusted are indicated by “o” in the appropriate column. Not all power trowel models include the same features and options and as such not all service operations may have to be performed. For ease of recording, place a checkmark (✓) through the “o” when the item is complete. If an item is not required or not completed place an “x” through the “o” in the box.
- For all fuel-line powered trowels the governed speed of the engine is 2000 to 3600 rpm. See engine manufacturer’s manual for exact specifications. Care should be used when making any adjustments to the power trowel not to change the governed speed. Increasing the governed speed of the engine may lead to premature failure and void the manufacturer’s warranty.
- Failure to have your power trowel regularly serviced and properly maintained in accordance with the manufacturer’s instructions will lead to premature failure and void the warranty.

SAFETY PRECAUTIONS

It is important that the following be read carefully in order that the operational performance of the Bartell Ride-On Power Trowel be fully understood. Proper maintenance procedures will ensure long life and top performance of the unit.

SAFETY PRECAUTIONS

- Always keep unauthorized, inexperienced, untrained people away from this machine.
- Rotating and moving parts will cause injury if contacted. Make sure guards are in place. Keep hands and feet away from moving parts.
- Fuel the machine only when the engine is stopped, using all necessary safety precautions.
- The engine must always be stopped before attempting any repair or adjustments. Ignition key should be off.

Danger: Never operate the machine in an explosive atmosphere, near combustible materials or where ventilation does not clear exhaust fumes. Repair fuel leaks immediately. Refer to your engine owner's manual for more safety instructions.

- Be careful not to come in contact with the muffler when the engine is hot, serious burns may result!
- Always operate the machine in a seated position to maintain machine balance.
- **The transporter is designed for moving the unit around the job site only. It is not to be used for towing the Ride-On unit off-site.**
- When starting the trowel, do not exceed the $\frac{1}{4}$ throttle position as recommended. A higher setting could cause the centrifugal clutch to engage, turning the trowel blades.
- Be careful with the trowel around stub pipes or other obstructions on the floor. Should the machine catch, or hit such an obstruction, serious damage may result to the machine, or operator may be thrown from the machine.
- Excess surface water may result in sudden loss of control of steering.
- Disconnect battery before attempting any electrical maintenance.
- Ensure that the electrical safety switch, located either under the left foot pedal or under the seat is engaged. Pressing the foot pedal down or sitting on the seat will engage the safety switch. Removing your foot off the pedal or standing up will disengage the safety switch and stop the engine. The engine will not start unless the safety switch is engaged. This safety feature must be used as designed.

ASSEMBLY INSTRUCTIONS

Your new Bartell Ride-On Trowel has been shipped to you partially disassembled. To prepare for operation use the following instructions:

1. STEERING HANDLE ASSEMBLY (Not applicable to BXR836 or BXR830)

The steering handles are shipped ready to connect. Position the handles over the handle sleeves so that the set-screws (2 per handle) are lined up with the tapped holes on the sleeves. Tighten the set-screws and test the mobility of the handles.

2. PITCH CONTROL ASSEMBLY (If required)

Bolt pitch control tube (C) to pitch control bracket (D) with bolts provided. Put cable end (E) through yoke arm (F) and secure with nylon insert locknut (G). For proper cable adjustment, turn crank (A) counter-clockwise to the stop position. Tighten nut (G) until all slack in the cable is removed. If more than 2 or 3 threads show through the nut, it should be turned back and the guide screw (B) moved to the next lower hole. Tension in the cable should then be readjusted. After adjusting tension, turn hand crank full clockwise (ABOUT 24 TURNS) and check for clearance between the yoke arm (F) and the gear box at point (H). There should be enough space to pass a business card through but not more than 1/8 inch.

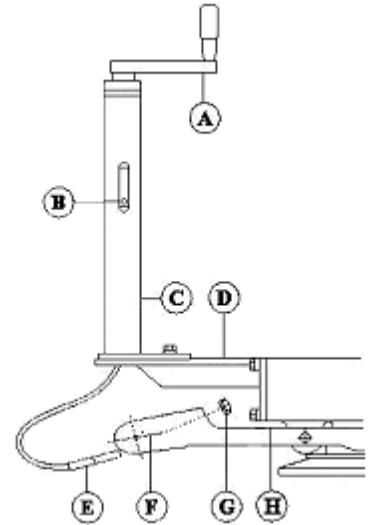

3. SEAT ASSEMBLY (If required)

Remove protective wrapping from seat. The seat is now ready to secure to the frame using included washers and hex nuts. If the seat adjuster is ordered, the slider bars must be positioned between the seat and the frame using included screws to secure the seat to the sliders, and then securing the sliders to the frame as indicated above.

4. TRANSPORTER ASSEMBLY

The components of the transporter (handle, frame, wheels, and parts bag) are shipped separately, requiring some assembly. Extend the handle outside the frame. Slide the handle along the frame cross-bar to align the hole on the handle with the hole on the “U” frame. Insert the large hitch pin (Part #12487) through the hole to secure the handle to the “U” frame. Position one of the wheels on the axle and secure in place by inserting pin (Part #10315) into the hole on the end of the axle. Repeat procedure for the other wheel.

CAUTION: The transporter is designed to be used on the job site only. Do not use the transporter to tow the machine off-site.

OPERATING INSTRUCTIONS

STARTING PROCEDURES - WARM TEMPERATURES

- Prior to starting the trowel, check the engine and gearbox oil levels. Be sure the fuel tank is full. Fuel is not shipped with the unit. Before attempting to start, fill the fuel tank. Check engine and gearbox oil levels. **WARRANTY IS VOID IF RUN WITHOUT OIL.** Fill tank with safety approved fuel containers. **DO NOT MIX OIL WITH FUEL.**
- Maintain contact with the safety switch. Engine will disengage and stop if safety switch is released. Do not tape, tie-down, or otherwise attempt to bypass safety device.
- If starting a diesel hold the key between run and start for 15 seconds to operate the glow plugs if the engine is cold.
- Turn ignition key all the way. Allow engine to warm up before proceeding with full trowel operation.

STARTING PROCEDURES - COLD TEMPERATURES

Follow same procedure as above but allow for a longer warm up period of 3-5 min. (In cold weather, oil is much heavier to move. Extra time is required to heat the oil.)

STOPPING PROCEDURE

- Bring throttle to low idle and wait a few seconds.
- Remove left foot from safety switch.
- Turn off ignition key.

STEERING (Mechanical and Hydraulic)

Guiding the machine on the slab is quite simple but does require some familiarity before working with the machine. The controls respond as shown in Figure 2. Test the machine on a finished section of the floor, with the blades in a flat position, and the engine at a low revolution to gain the necessary feel for the steering. For straight line movement, move both handles as one in the direction you wish to travel. Move the handles in opposite directions to produce rotation on the machine's axis. Left handle forward, right handle backward for clockwise rotation. Left handle backward, right handle forward, for counter-clockwise rotation. Sideways direction is achieved by sideways movement of the **right** handle in the required direction of travel.

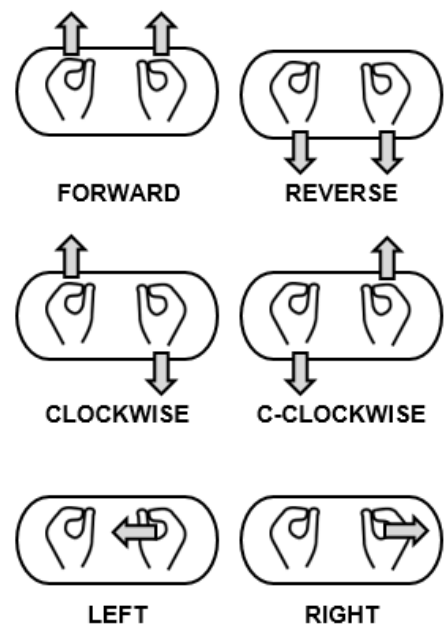

Figure 2

WARNING: Serious injury or property damage may result due to temporary loss of control if operated with excess liquid on the concrete surface.

FLOAT/TROWEL PITCH SETTING

Once you are familiar with the steering functions on a flat floor, you are ready to combine the steering with float/trowel pitch settings to produce the finish you require. The pitch adjustment feature of the Bartell Ride-On Trowel permits quick and accurate pitch changes of the finishing/float blades, without having to stop the machine. Turning the adjustment crank-handle at the end of the pitch control tubes enables you to change the pitch whenever necessary to allow for varying conditions over the slab surface. Each spider plate is adjusted independently. The pitch setting will affect the steering of your unit. Experiment with the settings as you test drive so you will know what to expect.

CAUTION: Do not let the machine stand in one spot on the soft concrete; this may place unnecessary strain on the clutch to break it free of the concrete. If the unit has been sitting for any length of time, break it free from the concrete before attempting operation.

NOTE: Ensure pitch is flat every time the rider is transported. Keeping the machine pitched creates strain on the pitch cable and can result in a broken or damaged cable.

CAUTION: When finishing concrete above grade, erect a situation barrier along the edge of the slab as a protective measure. The barrier must follow all applicable codes and should be such that it will stop the trowel from riding over the edge of the slab in case of loss of control.

BLADE SYNCHRONIZATION

(TS88, Titan 88, and specially modified units only)

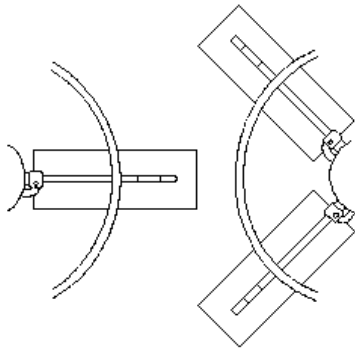

Figure 3.

To avoid blades hitting, make sure spider plates are positioned as shown with respect to each other after performing any maintenance.

TRANSPORTER USE

CAUTION: The transporter is designed to be used on the job site only. Do not use it to tow the machine offsite.

Titan 78, 88, 96

The transporter has pick-up brackets located on the inside of the wheels which should be positioned under the pick-up points on the frame. Before connection, the handle will be pointing upwards at approximately a 45-degree angle. Pull the handle down, engaging the transporter and secure the bracket and transporter to the frame by locking the handle bracket in the frame lock by means of the hitch pin. Using the handle as a lever, the ride-on may now be moved. To disconnect the transporter, follow the above steps in reverse.

TITAN TRANSPORTER INSTRUCTIONS

1. Remove the steering handles and fold the seat down. Locate the transport pins on the front and back of the chassis.

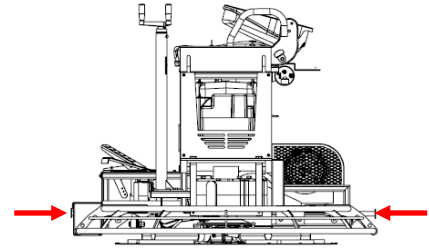

2. Angle the transporter so that the frame is almost vertical.

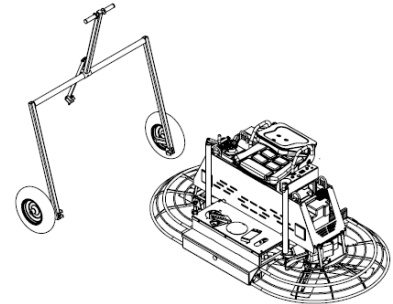

3. Roll the transporter over the machine, aligning the transporter brackets with the pins. Lift the transporter to connect the brackets with the pins. Then lower the wheels to the ground keeping the bracket and pins connected.

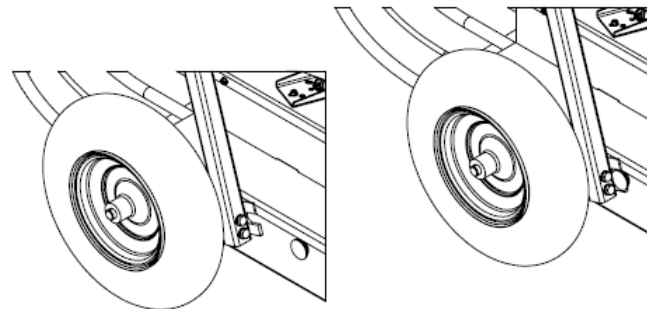

4. Bring the handle down and fit the pickup bar on the lowest ring of the chassis.

5. Slide the hitch pin into the pickup bar to secure it on the ring. Attach the cotter pin to the bottom of the hitch pin.

6. Use the handle to transport the Ride-On Trowel.

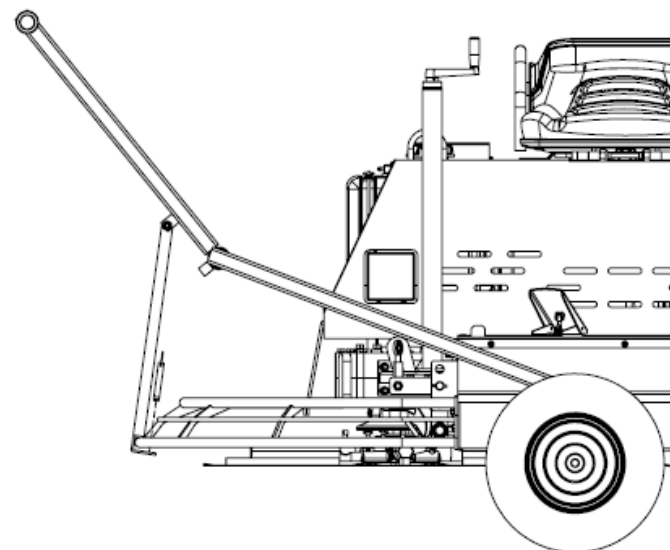

MAINTENANCE INSTRUCTIONS

GENERAL

Keep engine oil clean. Change according to engine manufacturer's specifications.

- Maintain the oil levels in the engine and gearbox assemblies. Change as required.
- Use only clean fuel in the engine.
- Check for loose nuts and bolts on the trowel and tighten as necessary.
- Check belts for wear, replace if worn.
- Grease all fittings daily. See diagram.
- Clean the unit after every use to prevent hardening of concrete residue. Hard concrete is very difficult to remove, greatly increases weight, and reduces efficient subsequent operation of unit.
- Check clutch linings regularly for wear. Linings should be changed when 3/4 worn. Do not allow metal to metal contact as this will damage the clutch drum. (New lining is 8mm.)

AIR CLEANER

Maintaining a clean engine will extend engine life.

Always keep air filter clean. Clean air filter using the recommended solvent. See engine manual for proper cleaning procedure. Let the filter dry before reinstalling.

SPARK PLUG

Check and clean spark plugs regularly. A fouled, dirty spark plug causes hard starting and poor engine performance. Set spark plug gap to recommended clearance. Refer to engine manual.

BELT CHANGE PROCEDURE

BXR836/830:

1. Remove belt cover from the machine to expose the drive components.
2. Release the belt tensioner to release the belt.

Titan 78, 88, 96:

1. Remove the cover from the pulley system.
2. Remove the U-joint by loosening the set screw near the shaft.
3. Remove the bearing plate.
4. Locate the threaded hole near the center of the driven pulley. Insert an M6 bolt to open the pulley.
5. Slip the belt off the driven pulley.

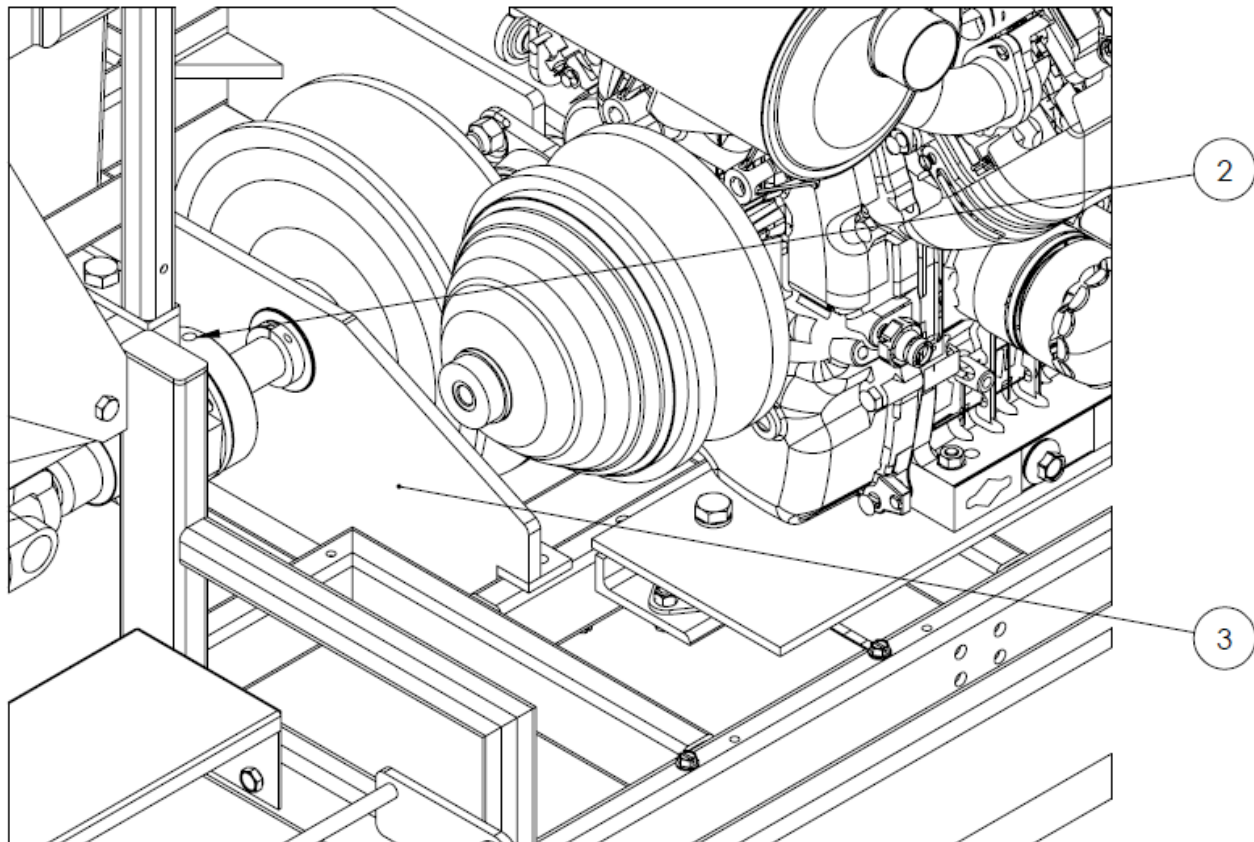
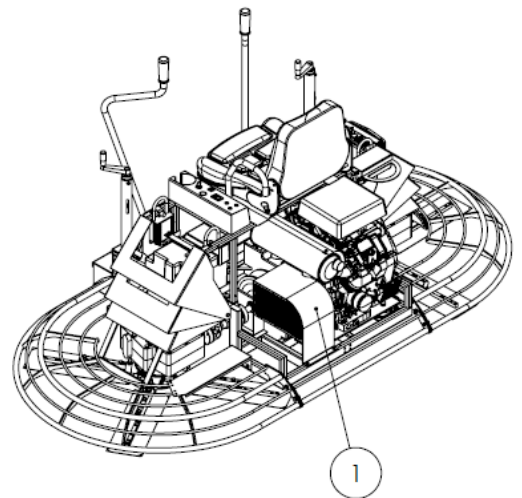

LUBRICATION

ENGINE OIL

The long life and successful operation of any piece of machinery is dependent on frequent and thorough lubrication. Before using the trowel, always check your engine for oil. Use proper engine oil as recommended in the engine manufacturer's manual. Fill crankcase to levels as recommended.

SPIDER PLATE

There is 1 grease fitting for each arm on the spider plates, each greased fitting must be greased daily. Ex. If there are 4 arms on the spider plate, then there are 4 grease fittings.

SPIDER PLATES MUST BE GREASED EVERY TIME MACHINE IS USED.

GEARBOX

Check the oil level sight plugs on both gearboxes daily to ensure the oil is half way on the site glass. For Titan gearboxes, check that the oil level in the level indicator is in line with the seam on the gearbox. Top up with Agma 8 MOBIL SHC Gear Synthetic ISO 680 oil only.

Model Number	Gearbox Capacity	
	Imperial	Metric
BXR830	27 fl. oz.	800 mL
BXR836	27 fl. oz.	800 mL
Titan 78	50 fl. oz.	1500 mL
Titan 88	50 fl. oz.	1500 mL
Titan 96	50 fl. oz.	1500 mL

TO CHANGE GEARBOX OIL

Place a pan beneath the drain plug to catch the oil. Remove the drain plug and the filler plug from the gearbox. After the oil has drained completely, replace the drain plug and tighten. Fill the gearbox through the filler plug with Agma 8 MOBIL SHC Gear Synthetic ISO 680 oil. Replace the filler plug and tighten.

GREASE FITTINGS

There are 6 bearings in total. Grease all bearings and U-joints to ensure adequate supply of lubricant. They are located above the gearboxes (2 per gearbox) and 2 located in the drive system. The U-joints are located in the drive system as well.

HYDRAULIC OIL

To change hydraulic fluid, drain the tank by removing the drain plug on the bottom of the tank. Reinstall the plug, remove the cap from the top of the tank and refill with Hydraulic Nuto 46 Oil. The oil should be approximately 3" from the top of the fill port, or if you look at the dip stick it should be ¾" from the top.

TROWEL ARM ADJUSTMENT FIXTURE

Part #20801
Unit 36" (TS88, BXR836, TS78,
All Titans)

- 1) 10411 – Trowel arm
- 2) 10817 – Lift lever
- 3) 10808 – Jam nut
- 4) 10809 – Set screw
- 5) 10824 – Block top
- 6) 10507 – Bolt
- 7) 10816 – Jam nut
- 8) 10815 – Carriage bolt
- 9) 10832 – Adjustment bar
- 10) 10507 – Bolt

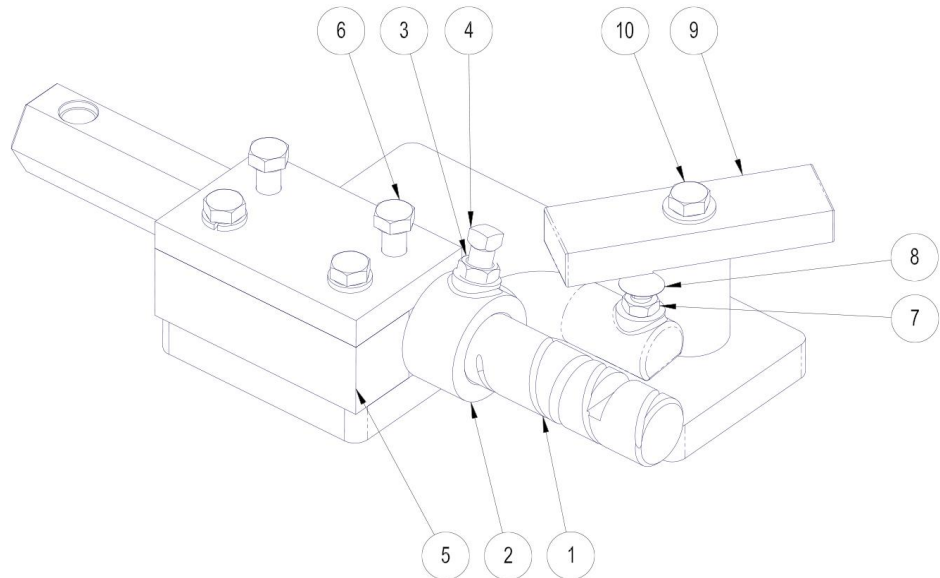

Part #20801
Unit 46" (TS96)

- 1) 14161 – Trowel arm
- 2) 14163 – Lift lever
- 3) 10808 – Jam nut
- 4) 10809 – Set screw
- 5) 10824 – Block top
- 6) 10507 – Bolt
- 7) 10905 – Washer
- 8) 10807 – Carriage bolt
- 9) 10832 – Adjustment bar
- 10) 10507 – Bolt

The trowel arm adjustment fixture (20801) is reversible. By rotating the arm clamping fixture and the ring bolt, both left hand and right-hand trowel arms may be adjusted. Before attempting adjustment, determine whether the trowel arm is right handed or left handed. When adjusting left hand trowel arms use the side of the fixture marked "L". When adjusting right hand trowels arms use the opposite side.

ADJUSTMENT PROCEDURE

1. Remove all trowel arm assemblies (1 & 2 arm and attached lift lever) from spider plate.
2. Remove lift lever (2) from trowel arm (1) by first loosening jam nut (3) then square head screw (4). If upon inspection (method left to discretion of serviceman) any trowel arm (1) is found to be in a bent condition, it must either be brought back to its original straight condition (method left to the serviceman's discretion) or replaced with new part.
3. Replace lift levers (2) on new or straightened arms (1) by reversing procedure described above.

NOTE: It is important that when tightening square head setscrew (4), it seats itself securely into dimple machined arm.

4. Place trowel arm assembly (1 and 2) in fixture (5) with lift lever (2) butting up against fixture. Secure in place with bolts (6).
5. Loosen locknut (7) and screw carriage bolt (8) down to full depth allowable. This will provide for ample clearance to swing adjustment bar (9) over head of carriage bolt.

Adjustment bar (9) is stamped for appropriate size of machine. Swing appropriate side directly over carriage bolt (8) and secure in place with bolt (10).

6. Adjust carriage bolt (8) upwards until contact is made with adjustment bar (9); holding carriage bolt in position with one wrench, tighten locknut (7) to secure in position with second wrench.

NOTE: It is vitally important to ensure that once the carriage bolt is adjusted to the correct height, it does not move before or during the tightening of the locknut.

7. Repeat this procedure with ALL arms of the spider plate assembly to ensure correct and exact adjustment.

TROWEL ARM ADJUSTMENT SCREW

When assembling trowel blades to trowel arms, the adjustment screw should NEVER protrude below the under-side surface to a trowel arm except when using for emergency on-site adjustment to level trowel blades. If the adjustment screw is not flush with the underside of the trowel arm, then this will cause the power trowel to bounce and vibrate especially at high speed. This will also cause the trowel blades to leave an uneven finish on the concrete due to the blades not being level to one another. Make certain that the adjusting screw is held firmly in place while tightening the bolt which secures the blade to the trowel arm.

TROUBLESHOOTING

WON'T START

- Throttle fully open
- Hand lever wire broken
- No gas
- Dirty gas
- Gas filter plugged
- Gas line plugged
- Hole in gas line
- Gas supply valve turned off
- Safety switch inoperable (foot lever must be depressed)
- Safety switch wire or connectors not making good contact
- Other engine problems (Refer to engine manual)

STARTS BUT NO HIGH SPEED

- Engine problems
- Throttle cable broken or seized
- Throttle lever and connectors loose or out of adjustment
- Clutch shoes worn

TROWELS TURN, ENGINE AT IDLE

- Idle adjustment is too fast
- Belt too tight
- Clutch seized

MACHINE JUMPS ON FLOOR

- Concrete hardened on bottom of spider plate
- Trowels unevenly worn
- Spider plate seized
- Spider plate loose
- Spider/Trowel arms bent
- Adjusting screws (carriage bolts) set incorrectly - use spider plate adjustment jig (page 19)
- Main shaft bent
- Steering handle too far right or left

SPIDER PLATE HARD TO GREASE

- Fittings plugged
- Cement in grease grooves of arms
- Grease fittings too tight
- Old grease has congealed

PITCH CONTROLS WILL NOT OPERATE BLADES

- Pitch cable broken or out of adjustment
- Slot screw missing (under-side of handle)
- Pressure plate and/or yoke arm broken or badly worn
- Hand crank adjuster not working

BELT WEARING RAPIDLY

- Belt adjusted improperly
- Pulley out of alignment
- Wrong belt/defective belt
- Clutch sticking
- Gearbox seizing
- Belt rubbing

OIL LEAKS

a) Top of gearbox

- Engine leaks oil
- Relief valve broken
- Too much oil in gearbox
- Set screw missing in cover

b) Between end cap and gearbox (recoil side)

- "O" ring damaged
- End cap not tight

c) At main shaft or countershaft

- Relief valve seized
- Shaft and/or seal worn

BLADES HITTING EACH OTHER (TS/TITAN 88 ONLY)

- Blades out of synch
- Sheared key in spider plate or gearbox
- Drive shaft misaligned

WON'T MOVE FORWARD OR REVERSE

- Pins or forward/reverse lever broken
- Rod end seizing on F/R lever
- Connecting rod broken

WON'T STEER LEFT OR RIGHT

- Steering arms broken
- Linkage worn out
- Gearbox studs sheared
- Rod end connecting shaft loose
- Bearings seized

DRIVE SHAFT WILL NOT TURN

- Universal joint(s) seized
- Spline stripped
- Key(s) sheared

Page intentionally left blank.

Page intentionally left blank.

CONTRACTOR PROVEN EQUIPMENT SINCE 1946



170 Traders Blvd E
Mississauga, ON L4Z 1W7
Canada

4701 Allmond Avenue
Louisville, KY 40209
United States

200 Commerce Drive
Freehold, NJ 07728
United States

Honeyholes Lane
Dunholme, Lincoln LN2 3SU
United Kingdom

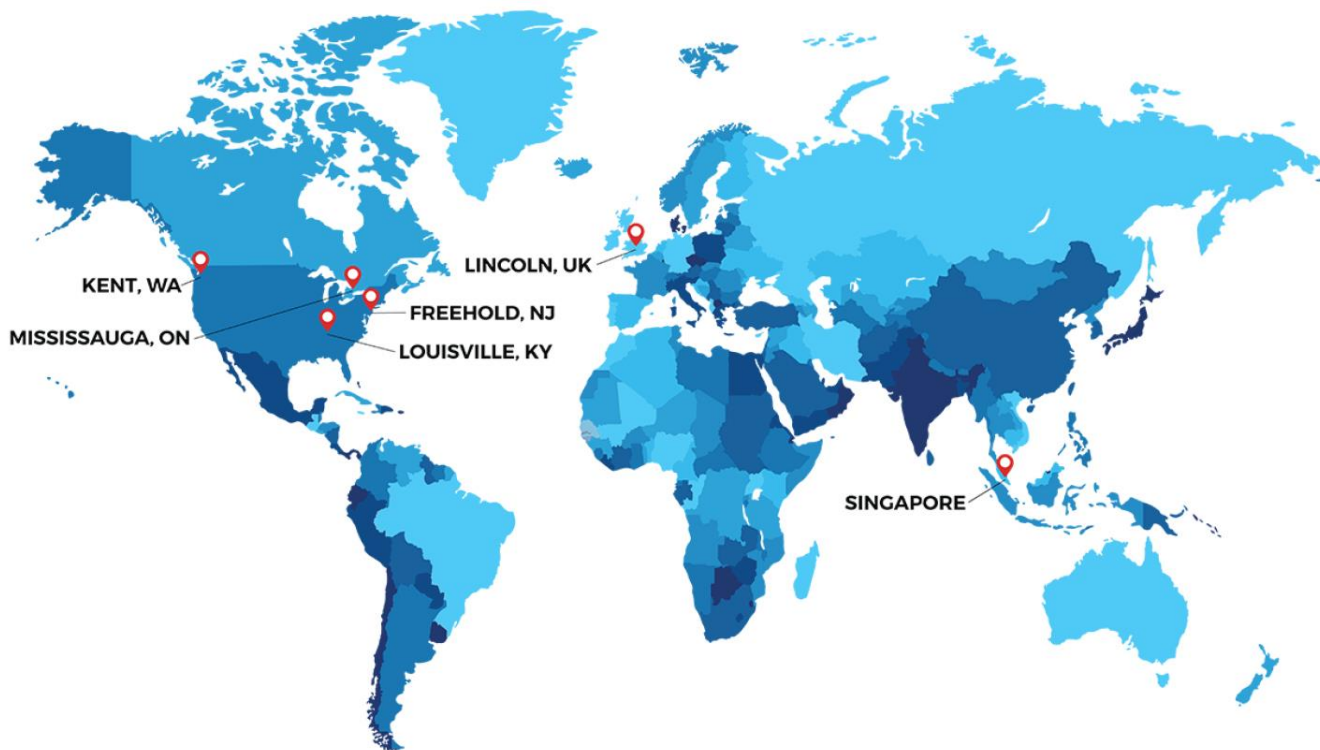

BartellGlobal.com