

BARTELL MORRISON (USA) LLC

Manual De Operacion

IDP 1410 Serie Sierra
Español



Antes de usar esta maquina, favor de leer este manual profundamente, y gualde para referencia futura.

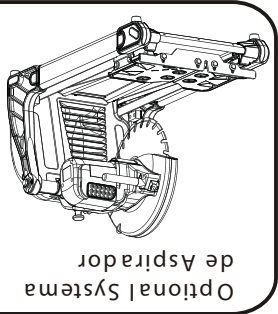

Optional Systema
de Aspirador

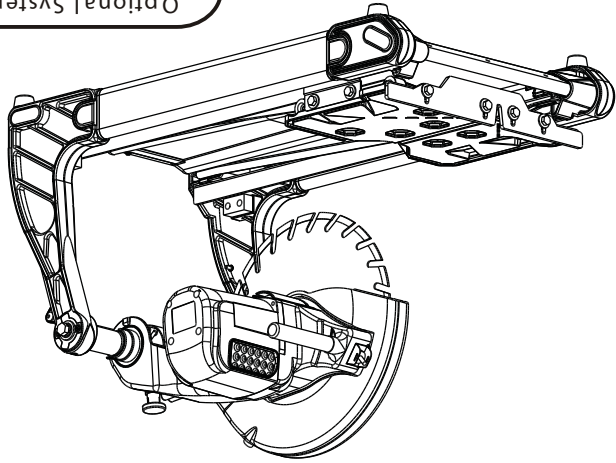

BMi
BARTELL MORRISON (USA) LLC

Owner's Manual
IDP1410 Series Masonry Saw

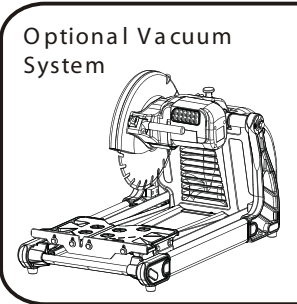
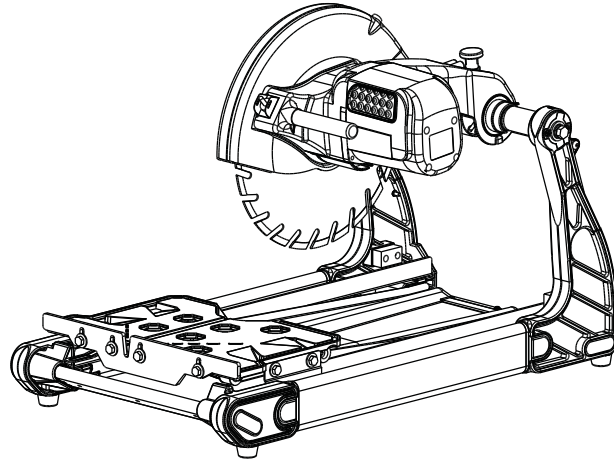

Optional Vacuum
System

Before operating the unit, please read this manual thoroughly, and retain it for future reference.

BARTELL MORRISON (USA) LLC

TABLE OF CONTENTS

	◆ Page
Contents	1
Safety Precautions	2
General Safety Rules	3
Health Warnings	3
Unpack, Assembly & Set-up	4
Inspection & Specification	5
Features	6
Cutting Table Assembly	7
The Rip Guide	8
Cutting Depth	8
Spring Lock Pin	9
Carbon Brush Replacement	10
Air Filter Replacement	11
Electric Motor Specifications	12
Do's & Don'ts for Blades	13
Saw Maintenance	15
Optional Accessories	17
Assembly of Optional Dust Collector & Stand	18
Troubleshooting	19
Notes	22
How to Order	23
Customer Service	25
Contact Us	26
Warranty	27
Replacement Parts List	29
Exploded View	31
Spanish Version/ Version en Español	

SAFETY PRECAUTIONS

Saw blade should be inspected daily for excessive wear, core cracks, and arbor damage. Replace any blade that shows signs of damage.

- To mount blade, clean arbor and outer flanges, tightening nut securely.
- DO NOT place any portion of body in line with blade while it is rotating.
- To reduce risk of electrical shock, it is recommended to use GFCI and refer servicing to qualified professional.

Bartell Morrison recommends the use of these Safety Items when Operating the Saw:



WEAR HEARING PROTECTION



WEAR EYE PROTECTION



USE BLADE GUARD WHEN OPERATING SAW



WEAR BREATHING PROTECTION

GENERAL SAFETY RULES

- Never use the machine improperly or work in an unsafe manner.
- Always wear safety goggles, dust mask, and ear protection while operating the saw (to comply with ANSI-Z87.1).
- Always remain alert when the saw is in use. Failure to pay attention on the operator's part may lead to serious injury.
- Before you start working, familiarize yourself with the work site and its surroundings. Take notice of circumstances which may impede working or traffic, observe soil conditions (good bearing or not), and take measures to ensure safety (i.e. the shielding of roadworks from public traffic).
- Take measures to ensure that the machine is in a safe and trouble-free condition prior to usage. Use the machine only when all protective devices (i.e. guards, noise absorbers, emergency-off devices) are operating in the intended locations.
- A visual check of the machine must be made at least once a shift to ensure that visible damages or faults are recognized. Any changes (including changes in the performance or behavior of the machine) must be reported to the supervisor. If necessary, stop the machine at once and secure it.
- In the case of a malfunction stop the machine immediately and secure it. Fix the problem as soon as possible.
- For starting and stopping the machine follow the operating instruction steps and observe any indicator lights.
- Before switching the machine on make sure that the activated machine will be of no danger to anyone.
- Be sure to connect the plug to a properly grounded receptacle to reduce the risk of electric shock.

HEALTH WARNINGS:

Some dust are created by power sanding, sawing, grinding, drilling, and cause other construction activities contains chemicals known to cause cancer, birth defects or other reproductive harm. Some examples of these chemicals are:

- Lead from lead based paints,
- Crystalline silica from bricks and cement and other masonry products,
- Arsenic and chromium from chemically-treated lumber.

Your risk from these exposures varies, depending on how often you do this type of work. To reduce your exposure to these chemicals: work in a well ventilated are, and work with approved safety equipment, such as those dust masks that are specially designed to filter out microscopic particles.

3

UNPACK, ASSEMBLY & SET-UP

Open the container, carefully lift the saw frame handles and place it on a flat, level working area. Be certain that you have the following items before you discard the container:

- Saw
- 45°/90° Rip Guide
- Universal Wrench
- Owner's Manual
- Extra Air Filter

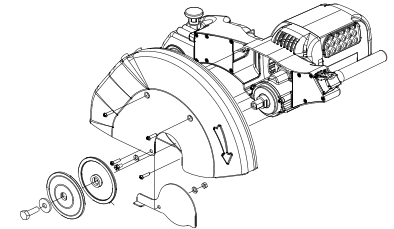

Diamond Blade Installation

- 1.** Move the blade shaft cover upwards. To remove the blade lock nut, open the shaft space.
- 2.** Place the 14" blade onto the blade shaft. Make sure that the directional arrow is pointing in the direction of the shaft rotation.
- 3.** Lock the blade lock nut with the outer flange. Use the multiple wrench provided to fasten the blade tightly.

4

INSPECTIONS & SPECIFICATION

The compact IDP1410 Masonry saws are shipped completely assembled and ready for use except for the diamond blade. Inspect the saw for shipping damage. If any damage is found, contact the shipper immediately and file a freight claim. BMI is not responsible for any freight related damages. Remove the saw from the shipping container.

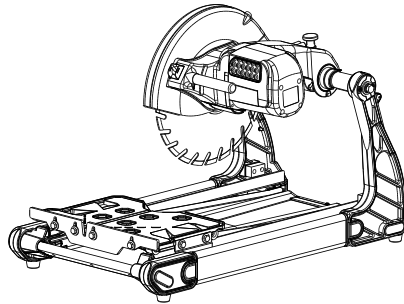

IDP1410 SPECIFICATIONS

Horse Power	3 HP (2,238 kW) Peak
Volts	115 - volts
Amps	15 A
Hertz (Cycles)	60 Hz
Motor Type	Carbon Brush
Bearing Type	Heavy Duty Sealed
Blade Shaft Speed	3,600 rpm
Maximum Blade Size	14 (356mm)
Arbor Size	1" (25.4mm)
Maximum Depth of Cut	5" (127mm)
Straight Cut Length	17" (431mm)
Maximum Material Size	8" x 8" x 16" (203mm x 203mm x 406 mm)
Dimensions L x w x H	31- 1/2" x 18 1/2" x 30" (800mm x 470mm x 762mm)
Weight Uncreated	75 lbs (34.1kg) Approx.

5

FEATURES

The IDP1410 Masonry Saw is designed for the professional contractor in mind. It enhances performance with a multitude of features facilitating operation.

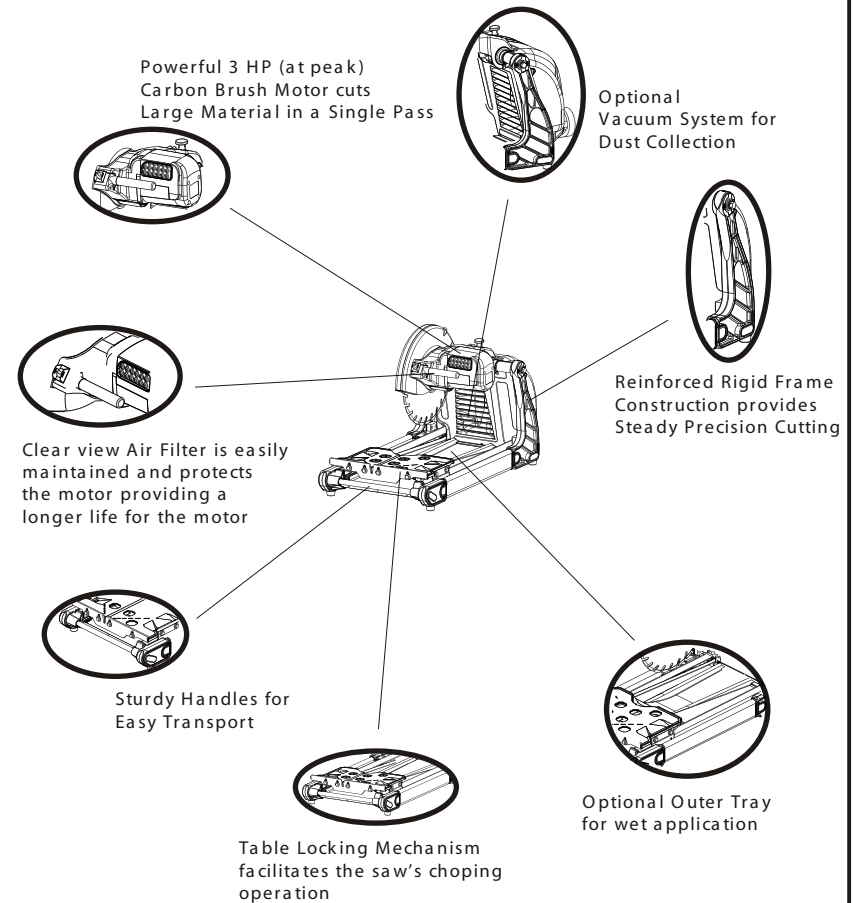

6

CUTTING TABLE ASSEMBLY

To install the Cutting Table to the machine:

1. Set the Cutting Table on the rails.
2. Install the screws and brackets to the cutting table.
3. To remove the Cutting Table do the reverse of the above two steps.

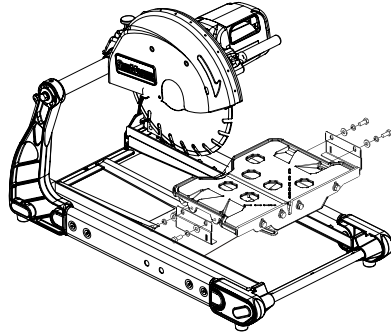

THE CUTTING TABLE

Features:



- The heavy-duty cutting table with Steel Wheels provides the durability to handle large materials.

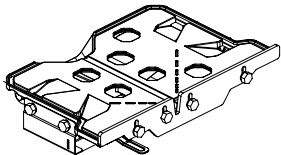

WARNING:

Only use the $\text{\O}14''$ blade for this saw. Setting smaller size of diamond blade may grab the material being cut, causing damage and possibly injury.

THE RIP GUIDE

Steps to Use the 45° / 90° Rip Guide

1. Set the rip guide by positioning it on the desired dimension and tighten the threaded knob. Make sure that the rip guide is firmly tightened to avoid slippage. The rip guide can be used for 90° rip cuts and 45° angle cuts from both the left and right side. (Note the straight and 45° angled slits on the bottom of the rip guide.)
2. After the rip guide is positioned for the desired cut, place material flat against the rip guide and the measurement rail.

- For 45° rip cuts, place the corner of material in the open slot of the measurement rail.
3. Simply line up the material being cut with the appropriate pre-marked lines on the cutting table.
 4. Now you are ready to make your cut.

CUTTING DEPTH

The recommended cutting depth is $\frac{1}{4}''$ below the cutting table surface. The cutting clearance has been fixed from original designed.

Blade Diameter

14''

Cutting Depth

5''

WARNING:

Only use the $\text{\O}14''$ blade for this saw. Setting smaller size of diamond blade may grab the material being cut, causing damage and possibly injury.

THE SPRING LOCK PIN

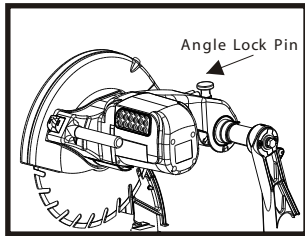

The IDP 1410 Masonry saw is designed with three different cutting heights for jam cutting, a moving head for chop (or plunge cutting), and a moving cart combined with the moving head for step cutting to help make any cutting task easier.

1. Before adjusting the cutting height always disconnect the electrical power supply
2. To adjust the IDP 1410's fixed cutting position, pull up on the Angle Lock Pin, move the head to the new position, release the Angle Lock Pin, and rotate the cutting head up/down until the Angle Lock Pin locks into position (lowest position for cutting thru bricks). The middle position is for cutting block and the upper position for blade replacement.

Chop / Plunge Saw Operation

To operate the IDP 1410 as a chop or plunge saw: pull up on the Angle Lock Pin, rotate 90 degrees, and release. Now the cutting head can be rotated by pulling up or pushing down on the cutting head handle. When not in use, always lock the head into one of the three cutting height positions.

HEAD POSITION	APPLICATION
Fixed Lowest	Jam Cutting Bricks
Fixed Middle	Jam Cutting Block
Fixed Upper	Diamond Blade Replacement
Moving	Chop or Plunge Cutting
Moving Head with Moving Table	Step Cutting

CARBON BRUSH REPLACEMENT

The IDP 1410 Masonry Saw uses a high horsepower low amperage air cooled brush motor. Replace the carbon brushes when the motor begins to lose power. Brushes typically need to be replaced during the life of the saw. Replace the brushes when over 2/3 of their original length is used (when the over all length of the brush is less than 7/16" (11.1mm). It is normal for the Brushes to wear down.

1. Disconnect the electrical supply
2. Remove the Air Filter.
3. Remove the four (4) Motor Air In-Take Cover mounting screws (see Figure 4-1: Motor Air In-Take Cover Removal).
4. Remove the Motor Air In-Take from the motor.
5. Use a coin or wide blade screw driver to remove the Carbon Brush Cap. Use care not to damage the Carbon Brush Cap. Inspect the Cap for damage. If the Cap has any signs of damage replace (see Figure 4-2 Carbon Brush Removal).

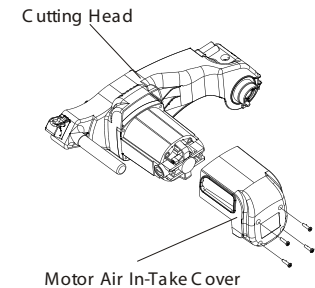
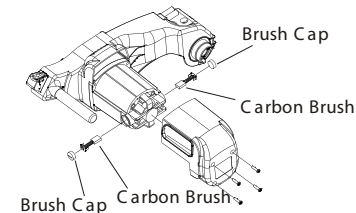

Figure 4-1: Motor Air In-Take Removal

Figure 4-2: Carbon Brush Removal



11. Reinstall the Motor Air In-Take Cover and re-attach the four mounting screws. Do not over tighten.
12. Clean the Air Filter.
13. Reinstall the Air Filter.

6. Remove the Carbon Brush.
7. Use compressed air to blow any access carbon build up out of the motor.
8. Rinspect the inside of the motor by looking into the brush holder for any excessive wear or carbon build up.
9. Place the new Carbon Brush into the Carbon Brush Holder.
10. Replace the Carbon Brush Cap and tighten the Cap with a coin or wide blade screw driver. Only snug the Cap down. Over tightening the Cap can cause damage to the Cap.

AIR FILTER REPLACEMENT

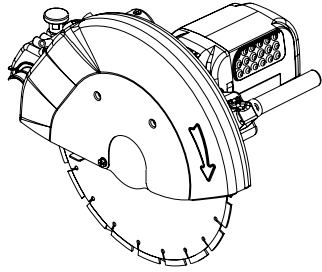

The IDP 1410 Masonry saw is equipped with a specially designed air filter to help protect the motor from damage due to high speed dust intake during operation.

To replace the Air Filter:

1. Carefully remove the old Air Filter from the Motor Air In-Take Cover opening. **NOTE:** Pull the Air Filter thru the opening in the front of the Motor Air In-Take Cover.
2. Inspect the new Air Filter for damage.
3. Place the NEW Air Filter into the Motor Air In-Take Cover.
4. The Air Filter should fill the opening in the front of the Air In-Take Cover and should completely fill the filter cavity.

WARNING:

Using the machine with a dirty, damaged, or missing Air Filter will result in motor damage and is not covered under warranty.

Steps to Clean the Air Filter

To clean the Air Filter:

1. Carefully remove the Air Filter.
2. Clean the air filter by patting, and shaking the dust from the filter. It can also be cleaned with water. After clean dry before replacing to the air intake. Compressed air can be used to blow the dust out of the filter.
3. Inspect the filter for damage. Any damaged Air Filter must be replaced before using the machine.
4. Replace the filter into the Motor Air In-Take Cover.
5. Check to see if the Air Filter is installed properly. The Air Filter should fill the opening in the front of the Air In-Take Cover and should completely fill the filter cavity.

ELECTRIC MOTOR SPECIFICATION

Features:

- Horsepower 3 H.P
- Volts 115 V
- Amps 15 Amps
- Motor RPM 3600
- Cycle 60 Hz
- Watts 2238

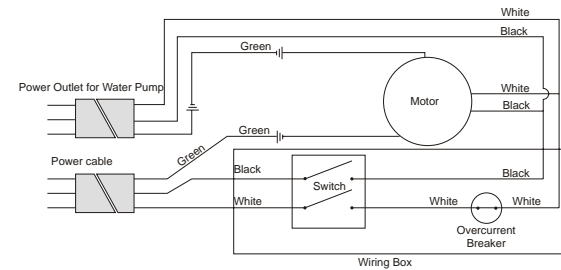
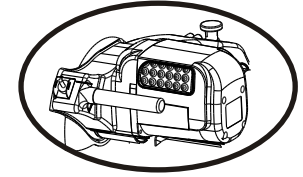

Recommendations:

- It is recommended that a 15 AMP CIRCUIT be used while operating this saw. This will prevent any loss of power or interruption.
- Always plug saw as close as possible to the power source while operating. This will allow you to receive optimum electricity.

WARNING:

To avoid permanent motor damage you must use the correct extension cord. Never use more than one extension cord at a time. Follow the chart for proper size:

WIRE GAUGE	LENGTH OF CORD
3 HP - 115 V	
No. 10	25'
No. 8	50'
No. 6	75'

DO'S & DON'TS FOR BLADES

DO'S

- Inspect blades daily for cracks or uneven wear.
- Always use appropriate blade for material being cut.
- Inspect arbor shaft for uneven wear before mounting blade.
- Always use blades with the correct arbor shaft size.
- Ensure that blade is mounted in the correct direction.
- Secure the blade to the arbor with a wrench.
- Use proper safety equipment when operating the saw
- Periodically check the blade for cracks or bond fatigue.

DON'TS

- Do not operate the saw without safety guards in position.
- Do not operate the saw with blades larger than 14".
- Do not cut dry with blades marked "Use Wet".
- Do not exceed manufacturer's recommended maximum RPM.
- Do not force blade into material let blade cut at its own speed.

DO'S

- In addition to the following, always follow wet recommendations.
- Use appropriate blade for material being cut.
- Inspect segment blades for segment cracking or loss.
- Do not use damaged blades.
- Use proper safety equipment when operating the saw

DON'TS

- In addition to the following, always follow wet recommendations.
- Do not make long cuts with dry blades-- allow them to air cool.
- Do not use the edge or side of blade to cut or grind.
- Do not attempt to cut a radius or curve.
- Do not cut too deep or too fast into the material.
- Do not cut any material not recommended by blade manufacturer.

**WARNING :**

For your safety before performing any maintenance on the saw turn off the power switch and unplug the power cord.

Cleaning

After every use of the machine:

- Remove dirty water from container.
- Remove dirt and mud from the bottom of the container.

After wet cleaning and before using the machine again:

- Connect the machine to an electric power outlet equipped with a "GFCI" safety power breaker. If the safety power breaker cuts off the electrical power supply, do not try to operate the machine but have it checked by an authorized dealer first.

Before & After A Prolonged Time

Before not using the machine for a prolonged period of time:

- Clean and lubricate all movable parts.

After not using the machine for a prolonged period of time:

- Check that the legs are safely fixed.
- Check that all screw joints and nuts are fixed.
- Check that the roller table is in its guides and that it easily moves to and fro.
- With the sawblade removed, switch on the motor for an instant and switch it off again. If the motor does not run, have the machine inspected by a qualified

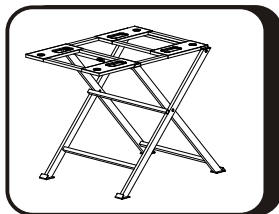

FOLDING STAND

Part No. **SDT-1410ST**

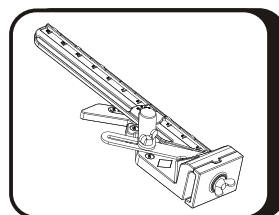

MASTER GUIDE

Part No. **S1000-MG**

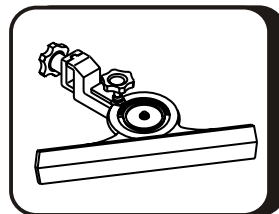

ANGLE GUIDE

Part No. **S1000-44**

OPTIONAL DUST COLLECTING GUARD ASSEMBLY

1. Place the Dust/ Collecting Guard on to the rear of the machine. The inner sides of the Splash Guard fits inside of the vertical up rights. The bottom of the Splash Guard has a flange with a rubber gasket glued to it, this flange fits over the outside rear of the water pan.
2. Align the holes in the Dust Collecting Guard with those in the machine's vertical uprights and those in the water pan.
3. Attach the one (1) Side Support Bracket to the inside of each side of the Dust Collecting Guard with the hex-head bolts and flat washers.
4. Place the smaller "U" shaped bracket over the inside of the water pan's rear flange .
5. Align the holes in the smaller "U" shaped bracket with the holes in the water pan's rear flange.

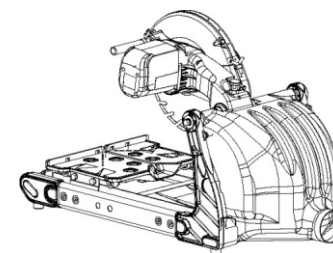

6. Place one (1) Carriage Bolt into each of the smaller "U" shaped bracket holes. Align the larger "U" shaped bracket holes with each of the threads of the Carriage Bolt and attach with the wing nuts.

OPTIONAL STAND ASSEMBLY

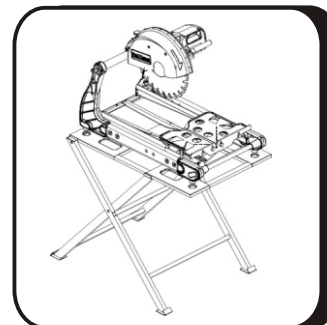

1. Remove the folding stand from its box.
2. Swing the working bench up-right. Open the two legs and place the workbench on top of the folding stand.
3. After the saw stand is completely assembled, place the saw on top of the saw stand.

TROUBLESHOOTING

PROBLEM	POSSIBLE CAUSE	SOLUTION
Machine does not run when switched on	- Power cord not properly fixed/plugged in	- Check that the machine is properly connected to the power supply
	- Power cord defective	- Have the power cord checked, replace if necessary
	- Main power switch defective	- Have the main power switch checked and replace if necessary by a qualified electrician
	- Loose electrical connection inside the electric system	- Have the whole electric system of the machine checked by a qualified electrician
	- Motor defective	- Have the motor checked and replaced if necessary by a qualified technician
Motor stops (power cut out)	- Too much pressure exerted while cutting	- Exert less pressure when cutting
	- Incorrect specification for saw blade	- Use a saw blade which corresponds to the material being cut
	- Saw has a defective electric system	- Have the electric system of the saw checked by a qualified technician
Poor machine performance little power	- Power cord/extension cable too long or cable still wound up inside cable drum	- Use a power cord/extension cable of the rated length, use a cable drum with cable fully extended
	- Power network is insufficient	- Observe the electrical ratings of the machine and connect it only to a power network which complies with these ratings

PROBLEM	POSSIBLE CAUSE	SOLUTION
	- Drive motor no longer runs at rated speed (r.p.m.)	- Have the motor checked by a qualified electrician and have it replaced if necessary
Irregular run of the saw blade	- Poor tension in the blade material	- Return the saw blade to the manufacturer
Saw blade wobbles when running	- Saw blade is damaged or bent	- Have the saw blade aligned/flattened - Clean the receiving flange
		- Solder the diamond segments of the old blade onto another saw blade or use a new blade
	- Flange of the saw blade is damaged Shaft of the motor is bent	- Replace the saw blade flange - Replace the electric Motor
Diamond segment becomes loose	- Overheating of the saw blade; cooling water not sufficient	- Have the diamond segment soldered on the blade again; ensure optimum flow of cooling water
Excessive wear	- Wrong type of saw blade - Shaft of motor causes wobbling - Overheating	- Use harder saw blades - Have bearings of the motor or the motor replaced - Ensure optimum flow of cooling water

TROUBLESHOOTING

PROBLEM	POSSIBLE CAUSE	SOLUTION
Cracks in or near the diamond segment	<ul style="list-style-type: none">- Saw blade too hard- Fixed flange is worn out	<ul style="list-style-type: none">- Use a softer blade- Have the fixed flange replaced
Saw blade is blunt	<ul style="list-style-type: none">- Motor shaft bearing- Saw blade type is unsuitable for the material being cut- Saw blade type is unsuitable for the machine performance- Saw blade too hard- Diamond segments are blunt	<ul style="list-style-type: none">- Replace the bearing of the motor shaft- Use appropriate type of saw blade- Sharpen the diamond saw blade
Appearance of cut is not optimal	<ul style="list-style-type: none">- Poor tension in the blade material- Too much load placed on the saw blade- Diamond segments are blunt	<ul style="list-style-type: none">- Return the saw blade to the manufacturer- Use a suitable saw blade- Sharpen the saw blade
The center hole in the saw blade has become wider due to wear	<ul style="list-style-type: none">- The saw blade has slipped on the motor shaft when running	<ul style="list-style-type: none">- The arbor of the saw blade must be fitted with an appropriate adaptor ring- Check the receiving flange and have it replaced if necessary
Saw blade shows blooming colors	<ul style="list-style-type: none">- Lateral friction when cutting	<ul style="list-style-type: none">- The material feed is too high; proceed more slowly
Grinding marks on the saw blade	<ul style="list-style-type: none">- Material is not being fed parallel to the saw blade- Poor tension in the blade material- Too much load on the saw blade	<ul style="list-style-type: none">- Ensure that the direction of feed is absolutely parallel to the saw blade- Adjust the roller table/have it adjusted- Have the saw blade tensioned- The material feed is too high, proceed more slowly

NOTES:

HOW TO ORDER:

Information Needed For Ordering:

Serial Number of the Saw
Model Number of the Saw
When it was purchased and where
Part Description

Prices

All orders are subject to Prices and Terms of sale in effect on date of shipment. Bartell Morrison changes its prices to reflect market trends in the industry, so that its products remain competitive in quality and pricing. Prices on bmiamerica.com are considered up-to-date and take precedence over any published prices (e.g. price lists, catalogs, and other forms of advertisements).

Promotional prices and discounts are subject to verification after order is placed. The customer will be notified if there are any errors found in pricing that affect the invoice amount.

Terms of Payment

Net 30 days from date of invoice, unless otherwise specified.

To Order:

We at Bartell Morrison pride ourselves on our customer service. If you need to order replacement parts, please contact our customer service department. You can e-mail or call us at the contact information listed below.

Customer Service:
Phone: (866) 501-1683
Web: www.bartellmorrison.com
Email: blyons@bartellmorrison.com

Delivery & Freight

Bartell Morrison reserves the right to select origin of shipment, routing and method of transportation.

Premium freight charges (such as air freight) will be at Purchaser's expense (shipped collect or added onto invoice). Written authorization by letter or fax must be received from Purchaser prior to shipment leaving Bartell Morrison. All Purchaser requests for such premium freight shipments, whether acknowledged in writing or not, are the liability of the Purchaser.

Material not in stock when order placed by customer will be shipped as soon as possible thereafter.

Return Merchandise Authorization (RMA)

No products are to be returned without prior Bartell Morrison written authorization and then only in accordance with Bartell Morrison's instructions and terms. Proof of Purchase (copy of Bartell Morrison's invoice along with serial number of items) should accompany all RMA requests.

All returned products must be in sellable condition, include all components, and be packed in original packaging. Any returns not satisfying these conditions will be promptly returned to the customer at their expense. The customer is liable for the purchase value of any damaged goods.

CUSTOMER SERVICE:

After Sale Service

All customer service (technical questions, re-order of parts, etc.) will be provided by Bartell Morrison.

Claims for Lost or Damaged Goods

If merchandise is delivered in damaged condition or cartons are missing, a notation must be placed on all papers signed by the receiver. If unreported or concealed damages are noticed after delivery, the carrier should be contacted by telephone and if carrier fails to send an inspector within five days, a request should be made in writing to the carrier, confirming the telephone request for an inspection.

All requests for credit due to transportation loss or damage should be accompanied by properly signed papers. A claim for loss or damage must be filed with the carrier within 60 days from the shipping date for UPS or other common carriers. Credit cannot be allowed for damage claims that are not properly substantiated with supporting papers or received by Bartell Morrison too late for timely filing with the carrier.

CONTACT US:

We pride ourselves on our customer service. If you have any questions regarding our products, whether it may be product inquiry or troubleshooting, please don't hesitate to contact us at our corporate office. We will do our best to answer your questions. In some cases we may even refer you to a local sales representative that can better service you. You can email or call us at the contact information listed below:



Customer Service:
Phone: (866) 501-1683
Web: www.bartellmorrison.com
Email: blyons@bartellmorrison.com

LIMITED 1 YR WARRANTY

1. SAW:

For a period of one (1) year from the original date of purchase, if the product is determined to be defective, BMI will repair or replace the product, at its option, at no charge to the customer, or pay the associated repair costs to a BMI authorized service facility. All replacement parts, new or rebuilt, supplied at BMI's option for repairs will be warranted for the remainder of the original warranty period of one (1) year. All defective products or components replaced under this limited warranty will become the property of BMI. This limited warranty excludes all components not manufactured by BMI, which are listed below with their corresponding independent warranty periods. Such components are warranted by their respective manufacturer, whose warranty will be the governing warranty for that particular product.

Excluded Components	Manufacturer's Warranty
Electric Motors	1 year

2. BLADE BOUGHT FROM BARTELL MORRISON:

If the bond between the steel core and segment or rim fails during the normal useful life of the blade, Bartell Morrison will replace the blade at no cost to the customer.

This warranty does not cover cosmetic damages or damages due to (1) misuse, abuse, negligence, accident, or modifications of the product or any of its components; (2) improper operation or failure to provide reasonable maintenance; or (3) attempted repair by any party other than a BMI authorized service facility. All products are subject to wear and tear under normal use. As such, the customer is responsible for all costs associated with the maintenance of said product, including the purchase of replacement components thereof.

To obtain warranty service, you must take the product, or deliver the product freight prepaid, in either its original packaging or packaging affording an equal degree of protection, to any authorized BMI service facility, along with proof of purchase in the form of a bill of sale, within the warranty period specified above. Warranty may be void if additional damages are incurred during transportation due to inadequate packaging.

BMI shall not be responsible for or obligated to pay for freight or other transportation related costs or expenses in connection with any defective products or components that are either returned to BMI facility or any authorized repair station and/or any replacement products or components that are shipped from BMI pursuant to this warranty.

BARTELL MORRISON SHALL NOT BE LIABLE FOR ANY INCIDENTAL OR CONSEQUENTIAL DAMAGES FOR BREACH OF ANY EXPRESS OR IMPLIED WARRANTY, OR NEGLIGENCE. SUCH DAMAGES INCLUDE, BUT ARE NOT LIMITED TO, LOSS OF PROFITS, LOSS OF REVENUE, LOSS OF USE OF THE PRODUCT, AND DOWN TIME. BMI'S LIABILITY SHALL NOT EXCEED THE REPLACEMENT COST OF ANY DEFECTIVE PRODUCT OR COMPONENT THEREOF. THIS LIMITED WARRANTY IS IN LIEU OF ALL OTHER WARRANTIES, WHETHER EXPRESSED OR IMPLIED.

Exclusions From Warranty

BMI cannot assume responsibility for claims arising from abuse of the BMI product:

- Due to abuse by the Purchaser in their processing.
- Due to improper installation practices or procedures.
- Due to abuse or improper usage by the end-user.
- Due to contaminants, including, but not limited to, exposure to salt or fresh water, chemicals and any other form of contamination from a source outside of BMI control.

REPLACEMENT PARTS LIST

IDP1410 SERIES

	PART NAME	PART No.
1	Screw	0305
2	Blade Guard	141002
3	Arbor Cover	25031 PR
4	Cross Bar Position Tube (Long)	141004
5	Blade Lock Bolt	25032
6	O uter Flange	25034PR
7	Arm Frame Left Side	141007
8	Rubber Cap	141008
9	Bolt & Washer Set (3 pieces)	141009
10	Side Frame	141010
11	Armature with Inner & O uter Bearing	141082
12	Cross Bar	141012
13	Rails(2)	25015PR
14	Dust Collecting Pan	141014
15	Cross Tube	141015
16	Metal Pan Bracket	141016
17	Metal Pan Frame	141017
18	Left Front Joint	141018
19	Cross Tube	141019
20	Arm Frame Right Side	141020
21	Right Front Joint	141021
22	Ruler G uide	141022
23	Complete Cutting Table	141023
23.1	Cutting Table Retention Bracket	141013
24	U-Shape Roller Wheels (2)	S1000J-24
25	Metal Bearing Rollers (2)	141025
26	Locking Table Bracket	2509495
27	Toggle Switch	141027
28	Toggle Switch Safety Bracket	100003
29	Inner Flange	25035PR
30	Plate Blade Shaft Retaining	25039
31	Shaft Spacer O uter	25161
32	Bearing Blade Shaft O uter	25160
33	Blade Shaft	25157
33.1	Key Woodruf	25156
34	G ear Blade Shaft	25158
35	Blade Shaft Inner Bearing	25153
36	Handle Bar	25062PR
37	Tension Spring Left Side	250221PR
38	Cutting Head Angle Main Bracket	25020PR
39	Inner Motor Bearing	25150
40	Tension Spring Right Side	25022PR

	PART NAME	PART No.
41	Spring House Cover	141041
42	Aluminum Motor Housing with Field Winding	141081
43	Air Filter	25077
44	Angle Adjustment Lock Pin	2504395
45	Cutting Head Casting	141045
46	Collar Set Cutting Head	25025PR
47	Cross Bar Position Tube (Short)	141047
48	Position Bracket Crossbar	141048
49	Motor Air Intake Cover	141049
50	Brush Cap	25098
51	Carbon Brushes (2 pc. Set)	25099
52	Main Cross Bar	141052
53	Shaft Spacer Inner	25159
54	Folding Stand	SDT-1410ST
55	180° Angle Guide	S1000-44
56	MasterG uide	S1000-MG
57	Multiple Wrench	S1000-41
58	Master G uide Template Base	S1000-MG 1
59	Master G uide Detachable Ruler G uide	S1000-MG 2
60	Main Cross Bar Position Stopper	141060
61	45° /90° Rip G uide	S1000-35
62	O uter Motor Bearing	141083
63	Motor Housing Screws M5 x 25L x P0.8 (qty required 4)	25155
64	Motor Air Intake Cover Screws M4 x 15L x P0.7 (qty required 4)	25105
65	Blade Guard Screws M5 x 15L x P0.8 (qty required 4)	25058
66	Rubber Feet (qty required 4)	141029
67	19 W Wrench	141037
68	Circuit Breaker	141038
69	Cable	141001
70	Motor Retaining Plate	141085
71	Wave Spring Washer	141084
72	Carbon Brush Cradle	141086
73	M4 x 0.7 x 8L Cross Screw	141087
74	Wire Box Cover	141088
	 Note: If there is any part that is needed and has not been included in this parts list, please contact our customer service 1-866-501-1683.	

IDP1410 SAW EXPLODED VIEW

IDP1410 DIAGRAMA DE LA SIERRA

Accessories (Included)
Accesorios (Incluidos)

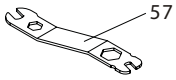

57

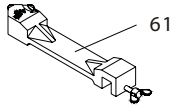

61

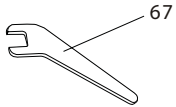

67

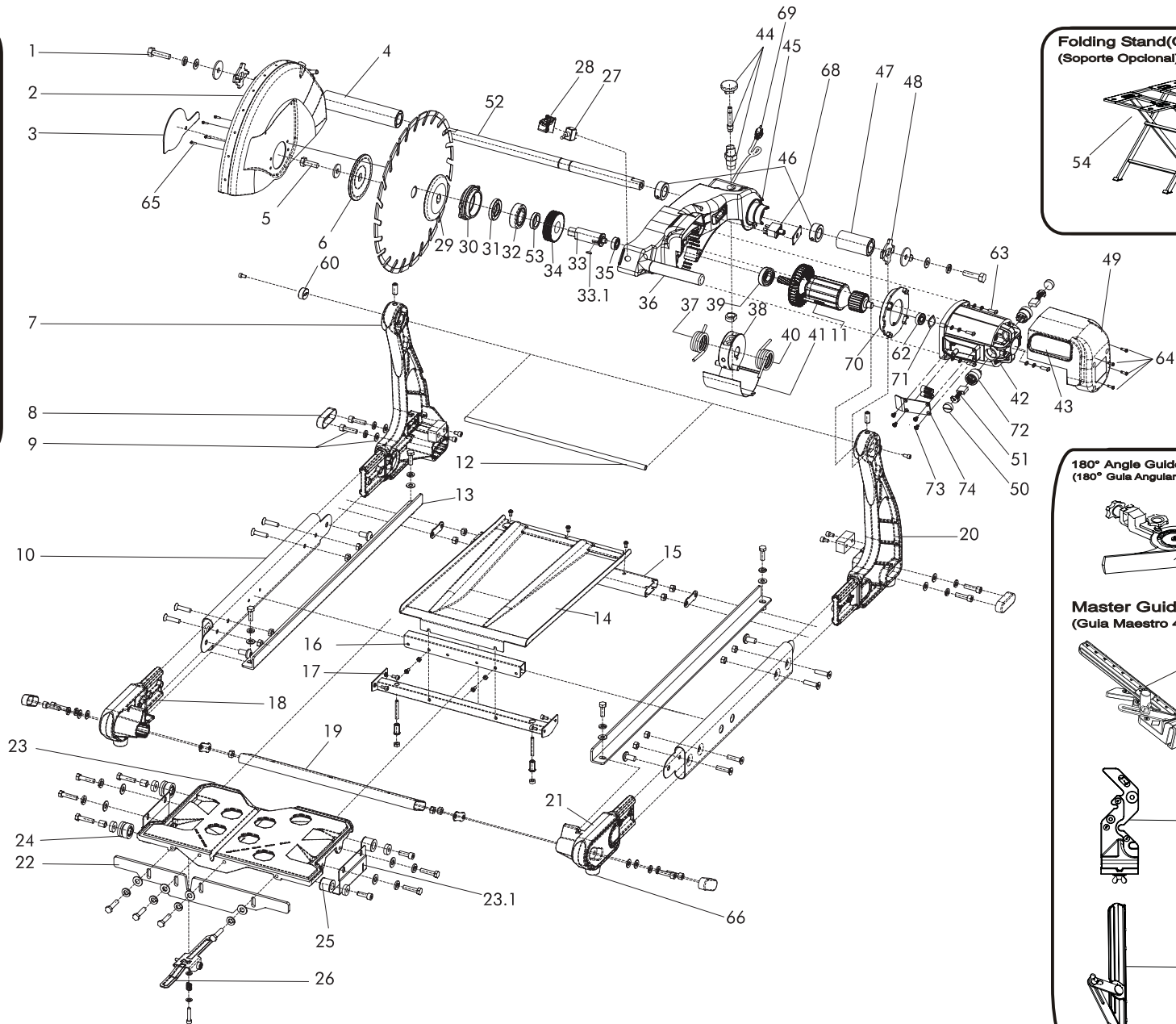

Folding Stand (Optional)
(Soporte Opcional)

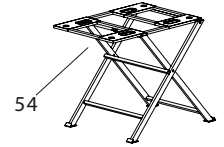

54

180° Angle Guide (Optional)
(180° Guía Angular Opcional)

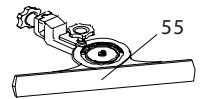

55

Master Guide 45° / 90°
(Guía Maestro 45° / 90°)

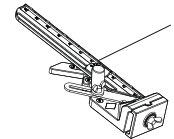

56

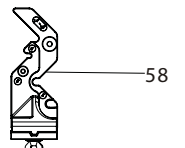

58

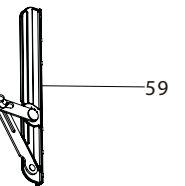

59