

SPE12E SUPER

Operating Manual

This manual is provided to persons purchasing an SPE machine and may not be reproduced in part or full without written permission of SPE International Ltd.

This manual provides the basic information required and is only to be used as a guideline. The SPE machines are manufactured and covered by SPE design registrations granted and pending. SPE International Ltd reserves the right to alter the equipment design and specification as required without notice.

The SPE product range is subject to amendment and improvement as a result of on going research



Honeyholes Lane, Dunholme, Lincoln LN2 3SU, England
Tel: +44 (0) 1673 860709 Fax: +44 (0) 1673 861119
Email: sales@spe-int.com

MACHINE DESCRIPTION

The **12E** series is developed generally for use in non hazardous areas. The machine is electrically driven with its own integral hydraulic system which operates forward and reverse drive of the machine.

The cleaning operation is performed by abrasive being thrown at high velocity against the surface to be cleaned. The throwing action is achieved through centrifugal force where a wheel with paddle type blades attached radial is revolved at a continuous shaft speed of 5000 rpm when using mains power at 50hz. Onto this wheel abrasive is fed in such a manner that it travels along the radial length of the blades and is then thrown off in a high velocity stream at the surface to be cleaned, thus efficiently blast cleaning the work surface. The energy put into the abrasive is sufficient to enable it to rebound from the work service. This rebound (kinetic energy) is used to recover the abrasive for re-use. The machine is designed so that the blast wheel is throwing abrasive at an inclined angle relative to the work surface. This means that after striking the work surface the abrasive rebounds at a similar angle into the reclaim duct, which directs it back into the hopper for re-use. Assisting with this reclaim cycle the air flow created by the dust collector enters the machine through a brush screen at the rear of the cabinet, flows across the work surface, up the reclaim duct, through the separator, into the dust collector and through the fan in to the atmosphere.

Abrasive is contained within the machine at the work surface level by seals at the front, a brush screen across the air intake at the rear and manganese and urethane seals at each side.

IMPORTANT NOTE - All equipment must be kept dry and not be used in wet conditions

IDENTIFICATION OF MAJOR COMPONENTS

The **SPE 12E** machine is assembled from several major components. It is essential that the operator becomes familiar with the names and functions of these separate components before attempting to carry out servicing procedures.

MAIN HOUSING

The main housing is the frame of the machine. Externally all other major components are attached to it and internally wear liners and all blast wheel components are fitted.

ABRASIVE STORAGE HOPPER

The hopper contains the abrasive.

SEPARATOR

Within this component which is fixed above the abrasive storage hopper the flow of abrasive and dust laden air is separated. It is constructed in such a way that as the air flow passes through it the speed flow is reduced. This results in the heaviest particles which are the steel abrasive falling out of the flow into the storage hopper for re-use whilst the lighter dust and debris stay with the air flow and pass through the separator on their way into the dust collector.

EXHAUST FAN ON THE DUST COLLECTOR

This component creates total air flow through the machine. Air is allowed into the machine through an aperture at the bottom of the back plate of the housing and then flows across the work surface, up the reclaim zone, through the separator, into the dust collector and then out through the exhaust fan.

DRIVE WHEELS

In conjunction with the front castor the left and right drive wheels are the machines means of support.

ELECTRICAL PANEL

Contains all the electrical equipment and the starter button for the blast motor and hydraulic pump motor.

DRIVE

The drive is an independent hydraulic system contained within the 'V' of the cabinet. It has its own oil tank. There is a simple on/off switch on the electrical panel to operate this motor. The flow of oil through the valve and the motor are governed by a flow control regulating the amount of oil which is directed to the wheel motors which then governs the speed of the motor whether in the forward or reverse position.

DIRECTIONAL CONTROL VALVES

These control the direction of the flow of hydraulic power to the drive wheel motors. The control has a three position function: forward, reverse and neutral.

Left and right controls are independent of each other giving instant forward or reverse precise steering control. If both controls are in reverse position the machine drives in reverse. If one control is in forward position and the other is in reverse position the machine will turn on centre point. Thus by using directional control valves through their independent forward, neutral and reverse range the machine can be manoeuvred precisely.

SPEED CONTROL VALVE

This controls the quantity of flow of hydraulic power through the directional control valves to the drive wheel motors. Rotating the speed control valve in an anti-clockwise direction decreases the flow and this decreases the speed of the machine in whatever direction the directional controls are set. Rotating the speed control valve in a clockwise direction increases the directional speed of the machine from stop to full speed. Therefore by using the speed control valve the forward/reverse speed of the machine is precisely controlled.

ABRASIVE FEED CONTROL LEVER

The abrasive feed control lever operates the butterfly valve in the feed spout between the abrasive storage hopper and the blast wheel. Forward is closed and as the lever is pulled backwards the butterfly valve is opened allowing abrasive to travel onto the blast wheel in a progressive controlled fashion.

ABRASIVE FEED CONTROL CAGE ADJUSTMENT

The control cage governs the point at which abrasive is put onto the blast wheel. Any particles fed on to a revolving wheel (such as is fitted to the SPE machine) will be thrown off this wheel in a downward direction from this point. Therefore with SPE equipment where abrasive must be thrown off downwards it follows the abrasive must be fed onto the wheel in an upwards direction. This will be set to an approximate position when the machine leaves the factory but as the cage wears it will be necessary to adjust the position of the cage to maintain optimum efficiency and production speed. The position of the cage should also be checked prior to any blasting operation.

ABRASIVE FEED CONTROL CAGE

The cage is a flanged sleeve with an opening in it. The abrasive flows through the centre of the sleeve and out of the opening into the blast wheel. The flange on the cage locates in the cage retaining ring welded to the machine housing. Turning the cage within its housing adjusts the position where the abrasive is put on to the blast wheel.

To find out where the machine is throwing its most concentrated abrasive pattern the following procedures should be followed with the machines positioned on a steel surface.

1. Check that the notch in the flange of the control cage is in its correct position (the notch indicates the position of opening in the cage sleeve which cannot be seen when the cage is assembled into the machine).
2. With the machine ready for blasting, open the abrasive control lever and load wheel. Without moving the machine allow this blasting operation to continue for approximately one minute.



3. Stop the abrasive flow and move the machine forward until the blasted area is accessible. With both hands feel the temperature of the blasted area. Caution the surface may become too hot and burn if left to run too long. The point which has received the most concentration of abrasive will be considerably warmer. An even temperature left to right indicates the control cage is correctly positioned. If the left side is the warmest then the cage needs to be moved in a clockwise direction looking from the front of the machine. If the right side is the warmest then the control cage needs to be moved in an anti-clockwise direction.

ABRASIVE FEED CONTROL CAGE FITTED IN POSITION

To make the cage adjustments, make sure the blast wheel motor is turned off and the blast wheel has stopped turning. Loosen the set of screws locking the control cage and move the cage in the desired direction, but no more than 1/4" (6mm). Then tighten the locking screws and start up the blast wheel and check the blasting pattern as in 2 and 3 above. This process is to be repeated until an even temperature across the blast pattern is achieved.

EYE PROTECTION

It is advisable for the operator and assistant to wear goggles even though the quantity of abrasive lost from the machine is very small.

EAR PROTECTION

It is advisable that ear protection is worn by both the operator and the assistant.

BLASTING PROCEDURE

The way a blasting job is carried out is often dictated by the shape and priorities of areas and the specification of the customer. However, all jobs will be carried out quicker if thought is given as to how the job is going to be tackled. Each owner/operator of SPE equipment should have the experience to adapt to a work method which suits him and the following points are the only ones which must be taken into consideration.

STEEL SURFACES

Steel tank surfaces are assembled from steel plates continuously welded together to meet the final dimensions of a tank. Therefore, a top or bottom always has a series of continuous welds across it in one direction (welds on the long side of the plate) and a series of intermittent welds across it (welds on long side of plate) and at right angles to the continuous welds (weld on short side of plate) both in the same direction. To achieve cleaning to the highest specifications (SA 2.5) it is essential that the blasting machine runs along in line with these welds.

In the case of large tanks where no dust collection systems is being used and assuming that the area to be blasted is the floor of a tank. The power supply will be placed as close to the manhole as possible. The machine will then be placed inside the tank via the same manhole and on completion of re-building, the machine will be placed in the desired position to begin blasting. The flexible ducting used on tank floor operations will then be laid out and connected up to the machine and taken to the outside of the tank where it will be connected to the dust collector. In a case where the machine is too far inside the tank to enable the single exhaust fan on the dust collector to function correctly it would then become necessary to introduce a booster fan placed not more than 120 feet from the machine in the line of flexible ducting. The ducting is led outside the tank and connected to the dust collector.

CONCRETE SURFACES

Blasting procedures to remove contaminates and/or paints from concrete surfaces are basically the same as those for cleaning steel, except that every operation must be carried out at a higher speed this alone dictates that the operator must be experienced.

Other differences are:-

1. Abrasive Feed It is recommended that abrasive feed to the blast wheel be kept low, between 10 and 12 amps, when the operation commences. This will give the operator an opportunity to get used to the relatively high forward speed necessary to make sure the concrete surface is not damaged.
2. Turning Whilst negotiating 180 degrees turn at the end of each blasting run the abrasive fed must be turned off otherwise during the turning process some areas under the machine will become over-cleaned causing possible damage to the concrete surface.
3. When commencing a blasting run the abrasive feed control must be operated at the same time as the speed control to ensure the forward motion of the machine commences immediately the abrasive starts to flow. If the machine stands still whilst the abrasive is thrown the concrete surface will be damaged.
4. Because quantities of debris removed from the concrete surfaces are considerable the dust pan which is below the dust arrestor must be emptied at short intervals. The dust collector must have stopped operating before removing the dust pan.

START UP PROCEDURE

1. First check the power supply is available and connected. This equipment must be protected at source by a 30 MA residual current circuit breaker.
2. Check to see that the hydraulic oil is at the correct level on the site level gauge located on the side of the hydraulic reservoir.
3. To rotate the blast motor press the green 'start' button adjacent to the blast motor label. Once the motor has attained the normal revolutions per minute the electrical trip system will operate fully after approximately 10 seconds and then the motor will run on 6 to 7 amps.
4. The large capacity fan which sits on top of the dust collector unit is operated by red and green 'on/off' buttons respectively. These are situated on the control panel. This fan needs to be in operation the whole time the machine is running. Without this fan in operation the machine will not function. The compressor and the pulsation unit must be started to clean the dust collector filters.
5. Press the green starter button to engage the hydraulic pump motor. This button is adjacent to the pump motor label. The pump is now operational and is already pumping oil to the control systems.

THE MACHINE IS NOW READY TO OPERATE.

START BLASTING OPERATION

1. Check that all electric motors are rotating in the correct direction. The method of manufacture ensures that if one motor is correct then all are correct.
2. Put one/two sacks (approx. 60 lbs / 25 kg) of abrasive into the abrasive storage hopper through the access door on the top of the separator.
3. The speed of the machine should then be judged and set by the operator prior to slowly pulling the abrasive feed control lever backwards. This will allow the abrasive to flow onto the blast wheel which will cause pressure to increase in the electric circuit. Continue to pull backwards on the abrasive feed control lever until the amp meter indicates a steady reading of approximately 15 amps. The machine is now throwing abrasive at the work surface and the machine is efficiently cleaning.

In practice it will be found that the work surfaces being blasted will vary from area to area and that the forward speed of the machine will have to be adjusted to suit varying conditions. The amounts of abrasive being fed to the blast wheel can also be adjusted to suit conditions.

4. Steer the machine with the directional control valves over the work surfaces varying the speed to produce the required blasting standard until the job is complete.

Whilst the blasting operation is being performed, the abrasive is contained within the machine at work surface level on both sides of the machine by seals that bear upon the surface under pressure applied by a spring plate above the seals

STOP BLASTING OPERATION

The blasting operation can be stopped using the following procedures in strict order:-

1. In one simultaneous operation push the abrasive control lever forward to cut the supply of shot to the blast wheel - pull the two hydraulic control leavers back to neutral position.
2. Press the red button controlling the blast wheel motor. This will stop the motor.
3. Press the red button controlling the pump. This will stop the pump.

BLAST WHEEL REVERSING PROCEDURE WHEN FITTED

1. Stop all electrical motors and isolate electrical supply to the equipment.
IMPORTANT the blast motor must have stopped turning.
2. Turn the reversing switch in the control panel to the opposite position it has been used (ie): 1 or 2, F or R.
3. Loosen the cage retaining set studs and tap cage around using a hammer and drift to opposite position (ie: mark in cage pointing to No.1 mark on the blast cabinet move to No.2)
4. Tighten up control cage retaining studs
5. Check the cage pointer and position are at the same number as the electrical reversing switch in the control panel
6. Using normal start up procedure ensure the blast pattern is correct

DAILY AND PERIODIC MAINTENANCE

Prior to any maintenance all electrical isolation must be carried out of all moving parts.

DAILY MAINTENANCE

The machine has only one wheel which requires lubrication and that is the front pivot wheel. The wheel requires two pumps with a grease gun daily.

OIL

Machine oil Grade H129/HM46

Compressor Oil Grade 30 DIN 51506

Hydrovane oil grade SAE40 DIN51506 or Red Force 2000

PERIODIC CHECKS FOR WEAR

If the machine is being used every day an inspection to assess wear taking place to the blast wheel blades and liners must be carried out every day. To carry out the inspection proceed as follows:-

1. Make sure the power unit is stopped and isolate the electrical supply
2. The machine can be tipped backwards and an inspection of the blades and liners can be made from underneath.

BLAST WHEEL BLADES

Wear will take place in the form of grooves worn into the blades along the path taken by abrasive from the centre of the blast wheel outwards. Wear grooves are acceptable until 90% of the blade thickness has been worn away. When this point is reached replace **ALL** the blades as a set.

FRONT URETHANE SEALS

Wear occurs through exposure to abrasive on the inside and by continually bearing on the work surface. Wear will be indicated by the increasing amount of abrasive left in trails on each side of the machine and the high velocity abrasive escaping forward of the machine

TO REPLACE FRONT SEAL SYSTEM

The seal system comprises of three separate urethane elements of differing depth and width. This is to ensure that a good fit is maintained between the side seals at both sides and the working surface at the bottom. Seals are located in a seal box across the front of the cabinet and are clamped in place by a bolt and plate system.

To obtain access to front seal system:-

1. Make sure power unit is stopped
2. Allow the machine to tip backwards until rear of the blast wheel motor rests on the work surface. This will lift the front of the machine and give access to the front seal locating box.
3. Unscrew the bolts across front seal locating box. This releases the clamp system holding the seals in place. Pull the worn seals out of the locating box.
4. Fit new seal section each interspersed with a steel strip. Tighten clamp and set screws.
5. Start up and commence work.

REAR BRUSH SEAL

Seal comprises of a single brush strip located in the seal box across the rear of the cabinet and clamped in place by two locking screws.

TO REPLACE REAR SEAL BRUSH

1. Unscrew the two locking screws and pull out the worn brush seal.
2. Fit new brush seal into the seal box and tighten the locking screws.

BLAST WHEEL BLADES AND IMPELLER REMOVAL

Wear takes place to these components with use.

To replace worn components:-

1. Make sure the power unit is stopped and isolate electrical supply.
2. Remove feed spout assembly
3. Remove the bolts holding the housing top cover and remove the cover exposing the blast wheel, blades etc.
4. Remove the two sets of screws holding the control cage and withdraw the cage from machine.
5. Prevent the blast wheel from turning by placing the lever between the blades from the top. Unscrew the hexagon headed screw from the centre of the impeller and remove.
6. Tap fingers of the impeller with a soft mallet until the impeller becomes loose avoiding the impeller fingers (tapered bottom section of the impeller locks the blast wheel blades in position). Then remove the impeller. This action will release the blades. The blades become tight in their slots after use and a hammer and bar is required to release the blades from their location slots.

TO REPLACE BLAST WHEEL BLADES

1. Prior to replacing blades make sure all dust etc is removed if possible by compressed air supply before fitting.
2. One by one fit blades. When all the blades are tapped into position the impeller can be fitted.
3. To fit impeller - notice there are notches cut into the lower tapered edge of the impeller and these locate with formations on the end of the blast blades.

4. Replace hexagon headed fixing screw and spring washer into the centre of the impellor and turn down tight. Tap fingers of the impellor with a soft mallet to ensure that the impellor is locating correctly.
5. Spin the blast wheel by hand to check by sight that the impellor is running true (any run out usually means that the impellor is not correctly located).
6. Finally, tighten the hexagon headed screw by placing bar between blast wheel and cabinet to stop rotation and then making sure the hexagon headed impellor fixing screw is really tight.
7. Replace the abrasive control cage (with notch uppermost) and control cage locking screws. At this stage rotate the blast wheel by hand to make sure there is nothing restricting or catching during rotation. Any such fault must be located and corrected.
8. Replace the housing top cover and fixing bolts.
9. Replace the feed spout assembly

Note: The blast wheel blades are supplied as balanced sets of seven. For this reason they must not be replaced as a single item or mixed with other sets of blades.

FAULT FINDING

1. DECREASED FLOW OF ABRASIVE

- a. Check there is sufficient abrasive in the hopper.
- b. Dump shot and check for obstructions on the screen in the hopper (usually paint flakes) or in the butterfly valve in the feed chute. To dump the abrasive open abrasive valve with the blast motor in a slow run or wind down speed.

2. MACHINE IS TRAILING/LEAVING EXCESSIVE AMOUNTS OF ABRASIVE BEHIND

- a. Check the dust collector is working correctly and efficiently
- b. Check that one or both side seals are not stuck/jammed up when fitted with manganese side seals.
- c. Check the fan is working on the dust collector at the correct rotation - 3 phase only.
- d. Check under machine and examine that the urethane seals are all in position and are not worn.
- e. Check blades, cage, impellor and liners are not excessively worn.
- f. Check the cage is in the correct position, if not adjust accordingly.

3. MACHINE DUMPS ALL ABRASIVE OR DUMPS OCCASIONALLY

- a. Check all items in 2 above.
- b. Check that the working surface is dry and is not contaminated with oil deposits etc.
- c. If the machine has dumped abrasive and after the hopper has been refilled make sure no abrasive is still under the machine blast area on the floor when re-starting to blast or the machine will not reclaim.
- d. If the machine occasionally dumps the abrasive when heavy blasting or exposing aggregates on concrete then slow the forward speed of the machine down and decrease the amount of abrasive being thrown down by the wheel to allow for the separation system to cope with the amount of debris being removed from the surface.

4. MACHINE SUFFERS REDUCTION IN BLASTING POWER

- a. Check all items above. If all are OK there must be a reduction in revs under load. Check the drive belts from the blast motor to the blast wheel.

5. NO SUPPLY OF POWER TO MACHINE

- a. If using a generator, check the panel fuses and circuit breaker switch is in the working position.
- b. If using the mains, check the fuses on the electrical supply.

6. POWER TO THE MACHINE BUT AN ELECTRICAL FAULT

FAULT

CHECK LIST

MAIN MOTOR

- | | | | |
|----|----------------------|----|--|
| 1. | No indicator lamp on | a. | 380v or 415v supply on, correct voltages on all phases |
| | | b. | MCB tripped |
| | | c. | Loose connections |
| | | d. | Test lamp and transformer |

- | | | | |
|----|--------------------------|----|---------------------------------------|
| 2. | Blast motor not starting | a. | Stop button not released |
| | | b. | Refer to List 1 then check following |
| | | c. | Over load tripped out |
| | | d. | Rotor has free movement on the motor. |
| | | e. | Motor connections |
| | | f. | Contactor main contact points burnt |
| | | g. | MCB tripped |

- | | | | |
|----|-------------------------------------|----|------------------------------------|
| 3. | Motor starts trips out on overload. | a. | Refer to List 1 check a,b & c |
| | | b. | Refer to List 2 check a,b,c, d & e |
| | | c. | Check test motor winding |

- | | | | |
|----|-------------------------|----|-------------------|
| 4. | Contactor not operating | a. | Test Timer units |
| | | b. | Contactor coils |
| | | c. | Loose connections |

FAN HYDRAULIC PUMP

- | | | | |
|----|--------------------|----|---|
| 5. | Motor not starting | a. | 380v or 440v supply on correct voltage on all phases |
| | | b. | MCB tripped |
| | | c. | Loose connections |
| | | d. | Overload trips out, check following:-
Rotor has free movement on the motor |
| | | e. | Motor connections |
| | | f. | Contactor - Contact points burnt |
| | | g. | Motor winding |

DUST COLLECTOR UNIT

These units are mobile and remote from the machines thus giving a high manoeuvrability to the SPE machine and are capable of dealing with high volumes of debris being removed.

OPERATION OF UNIT

Dust laden air is drawn by the exhaust fan into the cabinet to the filtration cartridges (filters), clean air is then exhausted through the fan to the atmosphere.

Dust filtration units are cleaned by blowing compressed air into them from the inside thus creating negative pressure on the external surface of filters allowing dust collected to fall into dust storage pan at the bottom of the cabinet.

The electronic pulse controller is fully automatic and requires no maintenance. The board and solenoids are 100v AC supplied by a transformer fitted within the panel. A facility is provided to enable the interval of the pulse and the duration of each valve to be varied to suit the characteristics of the compressor. The interval between the pulse should be approximately 7/8 seconds.

The duration of the pulse should be set so the compressor is just able to rebuild the pressure to the relief valve setting just before the 7/8 second interval is reached.

The relief valve on the compressor should be set at approximately 100 psi.

BASIC MAINTENANCE

ROUTINE INSPECTION

To maintain the optimum performance of the dalmatic filters a routine inspection should be made to minimise down time in the event of the malfunction of the equipment particularly on continuous performance applications. Any abnormal change in pressure absorbed across the filter elements indicates a change in operating conditions and a fault to be rectified. A prolonged stoppage of compressed air will cause an excessive build up of dust on the filter elements with consequent loss of suction.

After the fault has been rectified resumption of compressed air cleaning will return the filter to normal efficiency although it may be necessary to operate the Dalmatic Controller in still air conditions for a short period to dislodge the accumulated dust before putting the filter into operation.

To clear the filter elements switch off the main fan only and allow the pulse controller to perform several complete cleaning cycles before switching off the compressor etc.

DAILY/WEEKLY SERVICING SCHEDULE

A record should be kept of all pressure checks to aid speedy diagnosis of faulty operation.

1. Open the valve at the bottom of the moisture separator bowl and allow the collected water to drain off. Then close the valve. Drain tanks daily
2. Sealing - Check the dust seals on all joints for damage or ageing and ensure that they are properly seated. This is particularly important where the unit is located outside or in wet atmosphere to prevent entry of water. Faulty seals must be replaced.
3. Moisture separator - Isolate the compressed air supply then remove and clean the filter element.
4. Filter elements - Remove each filter and check the general condition of the filter. Clean each filter using a vacuum cleaner. If the dust is of an abrasive nature it is advisable to examine the elements more frequently. Filters showing holes must be replaced.
5. Jet tubes - check the tubes are clean and the jet orifices are clear.
6. Air manifold - Remove the drain plug and air inlet connections and clean out any accumulated sludge. Check the pressure relief valve for correct operation.
7. Compressor unit - Filter unit to be inspected daily and to be replaced on a weekly. Oil level to be checked daily and to be changed on a monthly basis

BASIC FAULT FINDING

These are three main faults which may occur.

1. Part loss of suction
2. Total loss of suction
3. Dust in the clean air outlet.

Service engineers should rectify any faults they may find during fault tracing, eg: Loose terminals , perished hoses etc.

LIGHT EMITTING DIODE (LED) INDICATION

- a. If the LED lights up then the electrical circuit should be operating satisfactorily
- b. If the LED is not operating, disconnect all the common output leads (ie: one per solenoid valve) from the PCB output terminal strip. Switch on and check for LED indication
- c. If it fails to light up, replace the fuse and check again
- d. If it still fails to light up, the PCB needs to be replaced



ASSISTANT INSTRUCTIONS

Normally the crew for the SPE machine consists of one trained operator and a trainee/assistant.

Whilst blasting operation is being performed, the assistant must carry out the following duties:-

1. Watch the hose being pulled by the machine to make sure it does not snag on any projection which might damage the hoses.
2. Assist by making sure there is sufficient free hose whilst the operator is carrying out 180 degree turn at each end of the blasting run.
3. Keep work area tidy by sweeping any abrasive scattered into the next run to be taken by the machine, where it will be picked up by the machine and re-used.
4. Generally assist with setting up the equipment by checking the oils, re-fuelling power unit etc.



SPE12E SUPER
Operating Manual

Spare Parts Breakdown

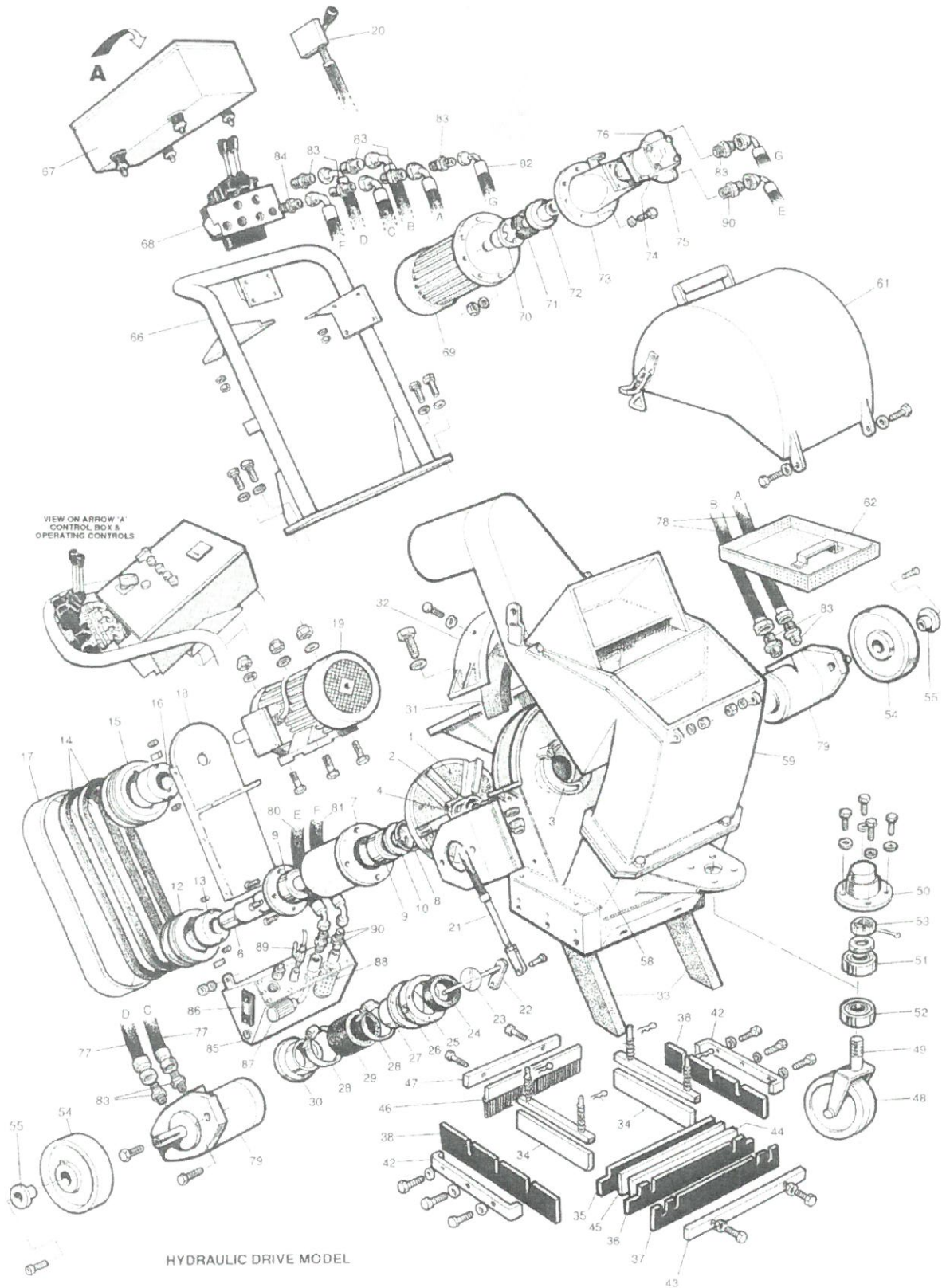

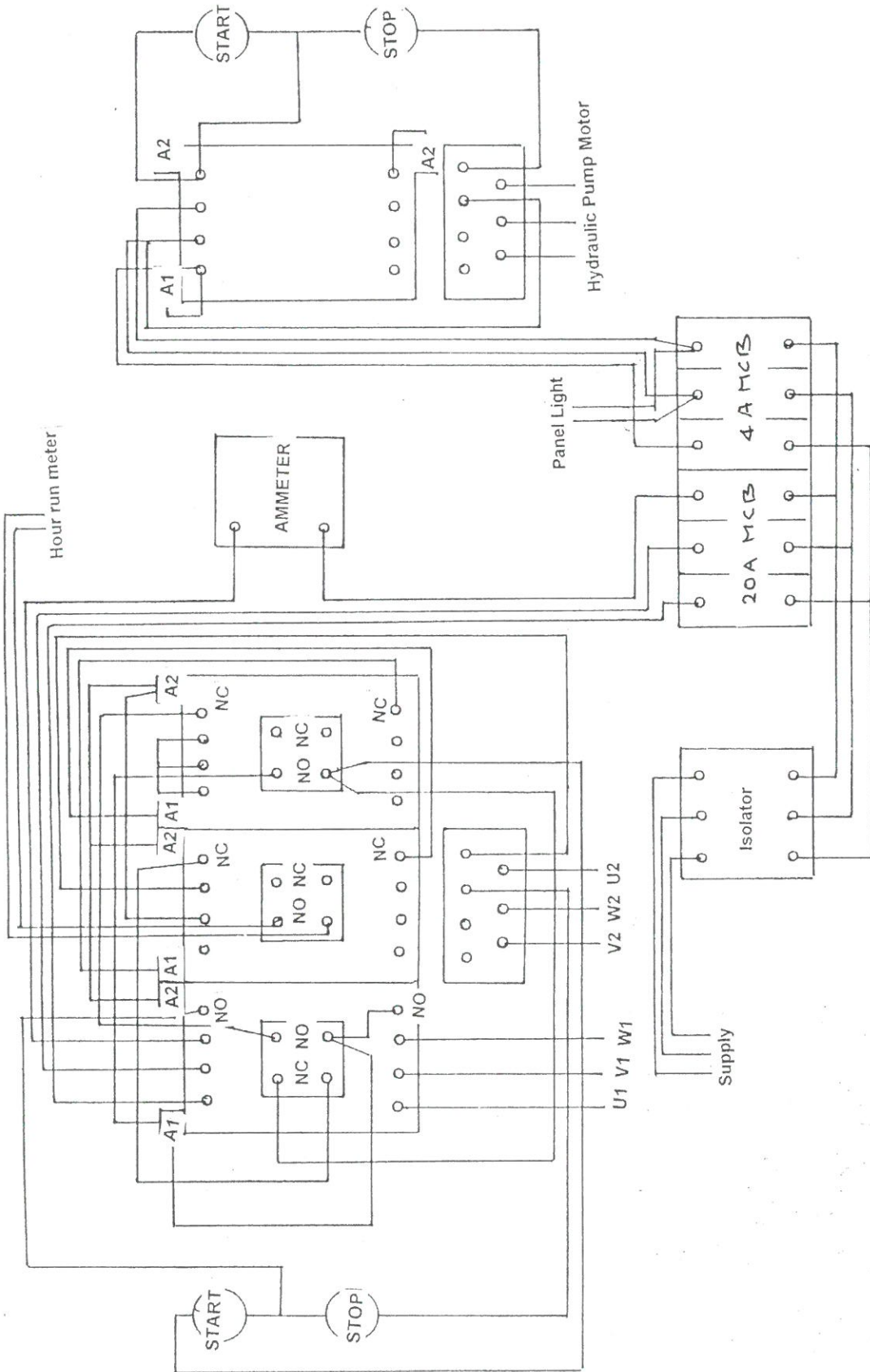

<u>Fig No.</u>	<u>Part No.</u>	<u>Description</u>	<u>Fig No.</u>	<u>Part No.</u>	<u>Description</u>
1	08000/12	Blast Wheel	50	07022	Hub
2	08001	Blast Wheel Blades (7 per set)	51	07021	Bearing Upper
3	08002/12	Control Cage	52	07032	Bearing Lower
4	08003/12	Impellor	53	07033	Castleated Nut
5	08004/12	Impellor Bolt & Spring Washer	54	07034	Drive Wheel (2)
6	08006/12	Blast Shaft	55	07035	Retaining Hub (2)
7	08032/12	Bearing Housing	56	09048	RH Wheel Motor
8	08033/12	Circlip	57	09049/12	LH Wheel Motor
9	08034/12	Bearing (2)	58	07000	Main Body
10	08035/12	Retaining Plate (Front)	59	07002/12	Separator & Hopper Assy
11	08036/12	Retaining Plate (Rear)	60	07036	Baffle
12	08029	Pulley (Blast Shaft)	61	07037	Separator Cover
13	08037	Taper Lock	62	07038	Grille
14	08028	Drive Belt (2)	63	07039	Handle
15	08038	Pulley (Blast Motor)	64	09050	Electric Drive Control Panel
16	08039/12	Taper Lock	65	09051	Enclosure (Transform)
17	08040	Belt Guard	66	07040	Handle
18	08041	Belt Guard Base Plate	67	09025	Control Panel
19	09019	Blast Motor	68	09010	Steering & Speed Control Valve
20	08042	Shot Valve Control Lever	69	09023	Hydraulic Pump Motor
21	08043	Control Cable	70	09052 /12	Motor Coupling
22	03025	Shot Valve Spindle	71	09053/12	Coupling Spider
23	08044	Shot Valve Butterfly	72	09054/54	Pump Coupling
24	08045	Shot Valve Liner	73	09055	Bell Housing
25	08046	Shot Valve Body	74	09042	Hydraulic Pump
26	08047	Oilite Bush (2)	75	09056	Port Connector (Inlet)
27	08031/12	Feed Spout (Hopper End)	76	09057	Port Connector (Outlet)
28	08048/12	Hose Clip (2)	77	09013	Hydraulic Hose (2) (R/H Wheel Motor)
29	08049/12	Shot Tube	78	09014	Hydraulic Hose (2) (L/H Wheel Motor)
30	08030/12	Feed Spout (Cage End)	79	09009	Wheel Motor (2)
31	08010	Hood Liner (Cast Manganise)	80	09015	Hydraulic Hose (Tank to Pump)
32	08050	Hood Liner Cover	81	09016	Hydraulic Return Hose (Valve to Tank)
33	08008	R/H Side Liner	82	09017	Hydraulic Hose (Pump to Valve)
34	08009	L/H Side Liner	83	09058	½" B.S.P.M-M Adaptor (10)
35	08011/12	Steel Side Seal (2) c/w Tension Bar, Spring and Clip	84	09059	½"x¾" B.S.P.M-M Adaptor
36	08012	Inner Front Seal	85	09060	Hydraulic Tank
37	08013	Intermediate Front Seal	86	09007	Sight Level Guage
38	08014	Outer Front Seal	87	09006	Filter (In Tank Suction)
39	08015/12	Side Skirt Seal (2)	88	09011	Diffuser (In Tank Return)
40	07015/12	Side Skirt Retaining Bar (2)	89	09008	Tank Breather Tap
41	07016	Front Seal Retaining Bar (Outer)	90	09061	¾" B.S.P.M-M Adaptor (3)
42	08052	Inner Seal Retaining Bar (Drilled)			
43	08053/12	Inner Seal Retaining Bar (Plain)			
44	08017	Rear Brush			
45	08054	Rear Brush Retaining Bar			
46	07018/12	Front Wheel			
47	07019/12	Stub Axle Assy			



SPE12E SUPER
Operating Manual

SPE12DC **Spare Parts Breakdown**

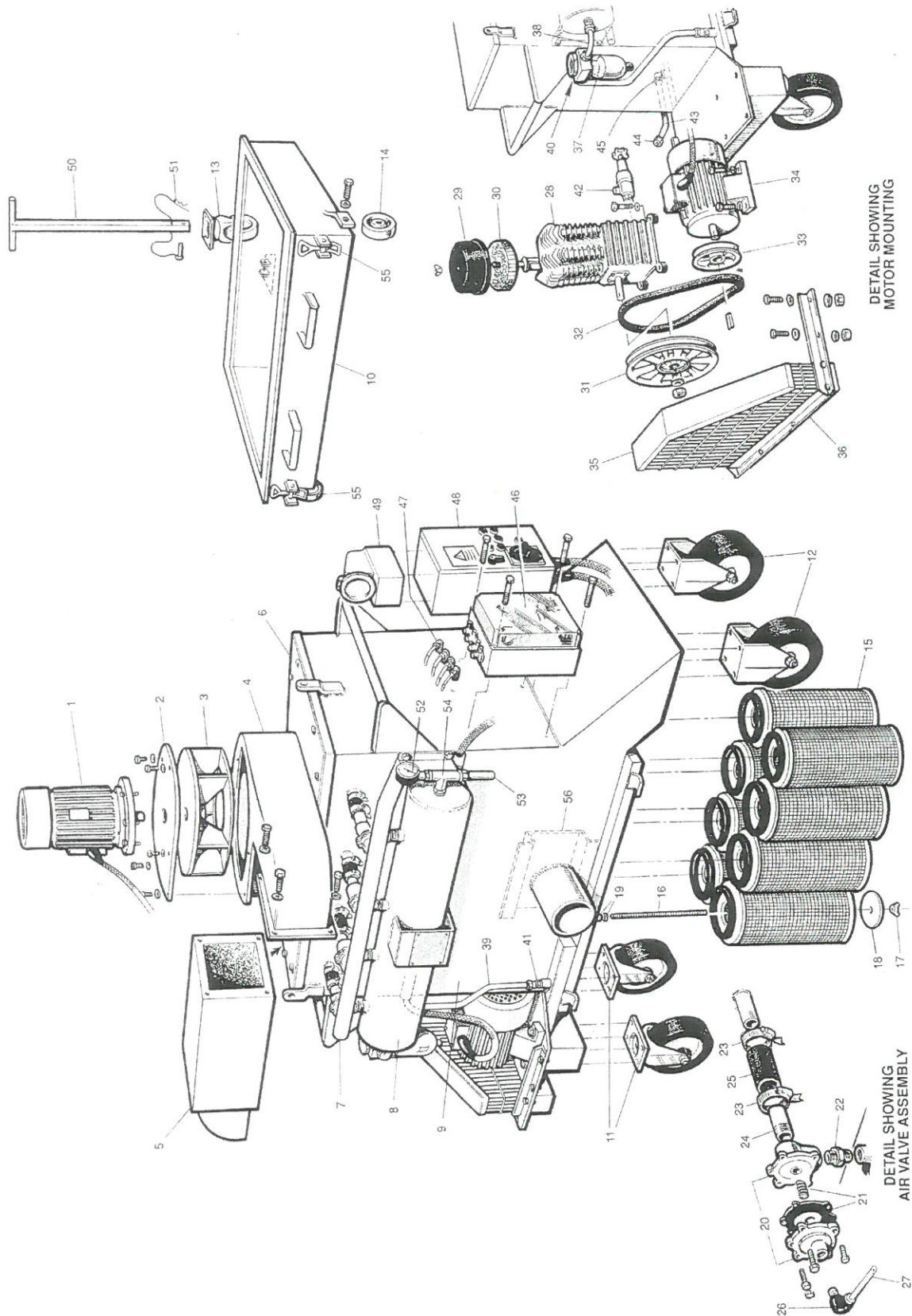

DETAIL SHOWING
MOTOR MOUNTING

DETAIL SHOWING
AIR VALVE ASSEMBLY

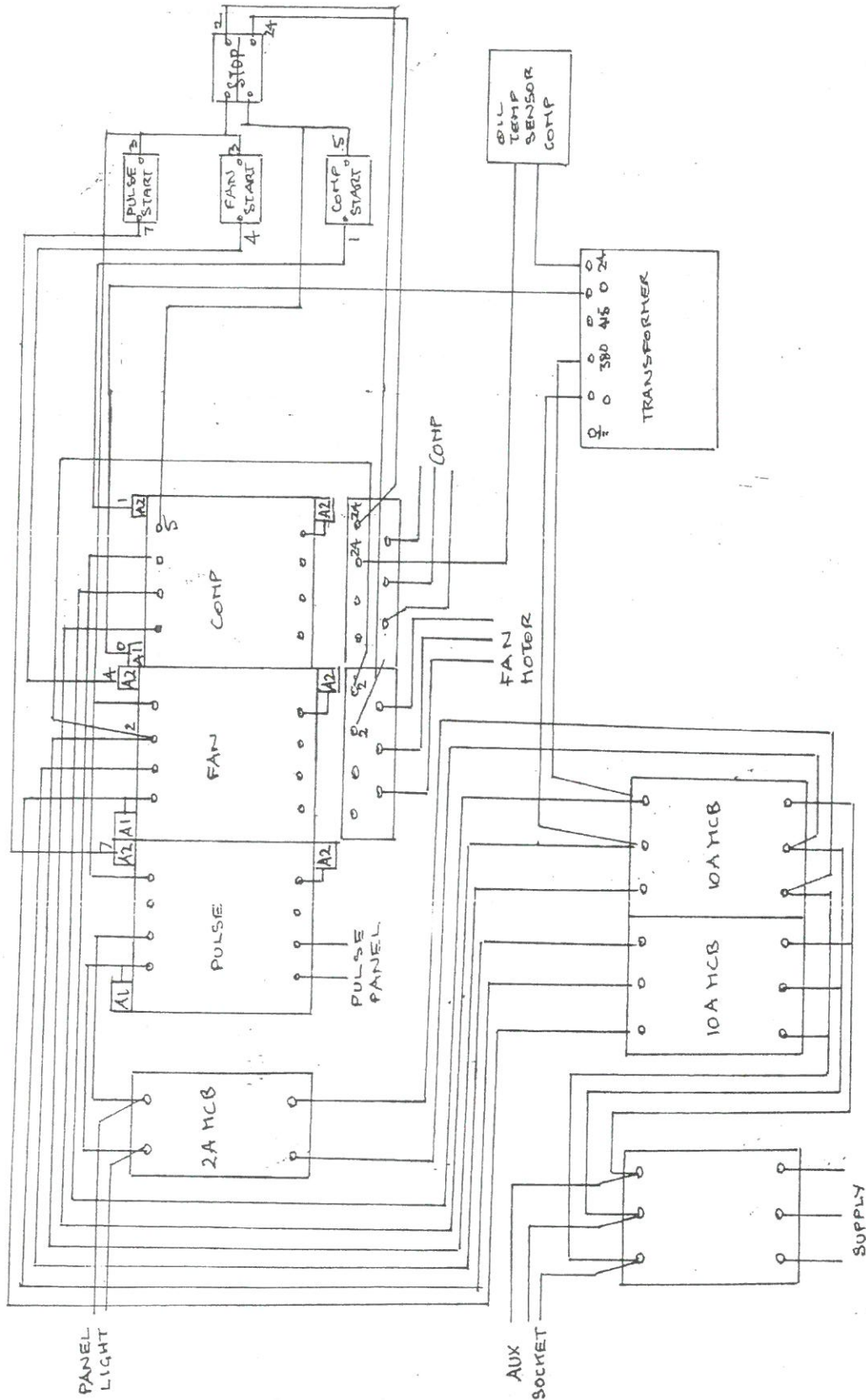

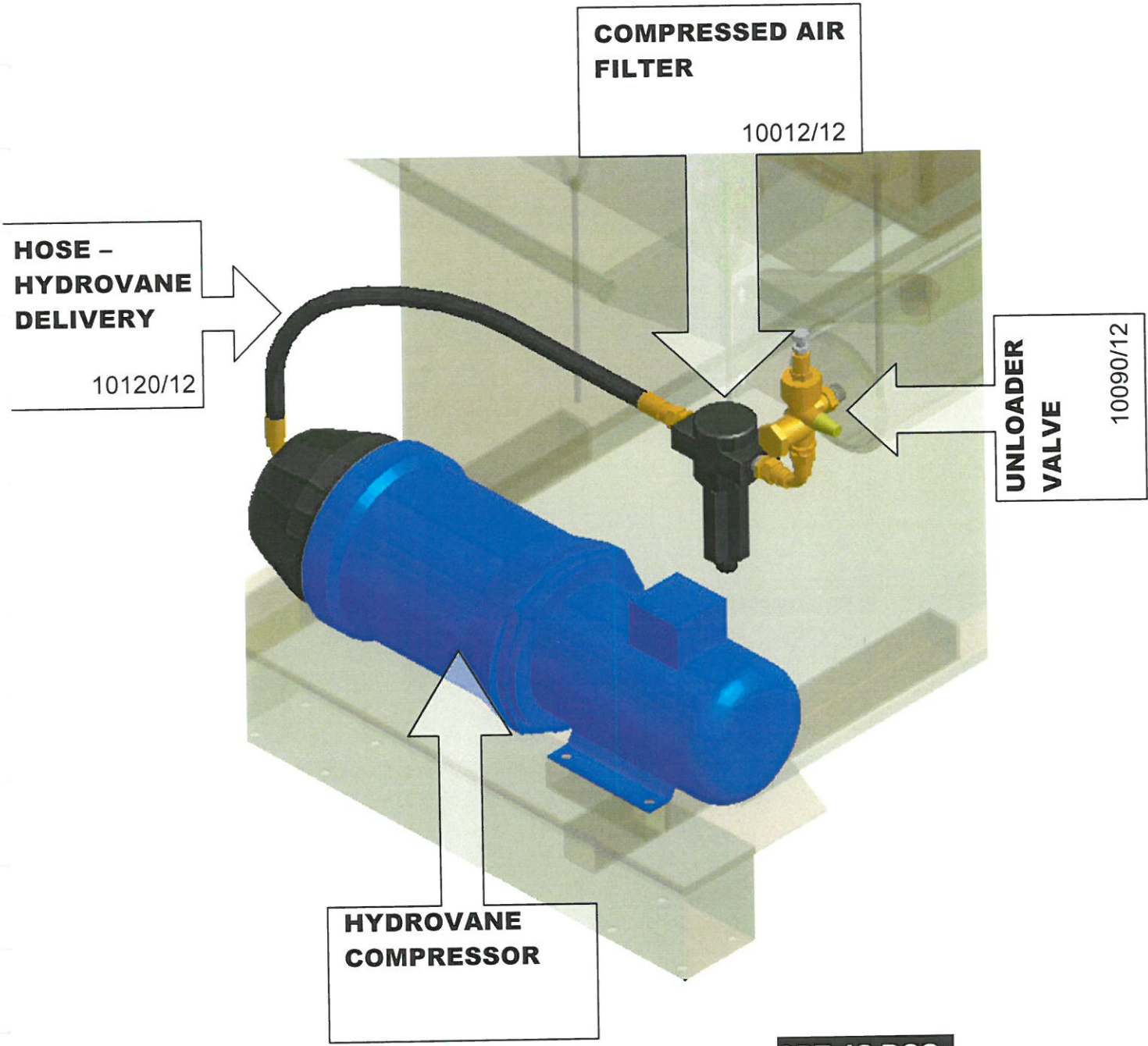

SPE 12 DCCs
Hydrovane Adaptation

<u>Fig No</u>	<u>Part No</u>	<u>Description</u>	<u>Fig No</u>	<u>Part No</u>	<u>Description</u>
1	10059	Fan Motor	29	10080	Air Filter Assy
2	01031	Fan Casing Top Plate	30	10081	Filter Element
3	10058	Impellor	31	10082	Flywheel
4	10057	Fan Casing	32	10063	Drive Belt
5	10065	Silencer	33	10083	Pulley
6	10066	Lid	34	10062	Compressor Motor
7	10067	Guard	35	10084	Guard Upper
8	10068	Air Receiver	36	10085	Guard Lower
9	10069	Main Body	37	10012	Compressed Air Filter
10	10004	Dust Tray	38	10086	Elbow
11	10050	Castor Wheel (2)	39	10087	Copper Pipe
12	10051	Fixed Wheel (2)	40	10088	Fitting (Pipe to Filter)
13	10052	Castor Wheel (2)	41	10089	Fitting (Pipe to Tank)
14	10053	Fixed Wheel (2)	42	10090	Unload Valve
15	10056	Filter Element (8)	43	10091	Copper Pipe
16	10070	Threaded Rod (8)	44	10092	Fitting (Pipe to Valve)
17	10071	Wing Nut (8)	45	10088	Fitting (Pipe to Tank)
18	10072	Flat Washer (8)	46	10054	Pulse Panel
19	10073	Hex Nut (16)	47	10093	Push-in Connector (4)
20	10036	Diaphragm Valve (4)	48	10055	Electric Control Panel
21	10037	Valve Repair Kit	49	10094	Electric Socket
22	10074	M-M Adaptor (4)	50	10095	Handle
23	70075	Hose Clip (8)	51	10096	Pin and Clip Assy
24	10076	Hose Connector (4)	52	10097	Pressure Gauge
25	10077	Hose (4)	53	10013	Pressure Relief Valve
26	10078	Push-in-Connector (4)	54	10098	Tee Piece
27	10079	Semi Rigid Piping	55	10064	Over Centre Clip (4)
28	10061	Compressor Pump	56	10099	Internal Baffle Plate

SPECIFICATION SHEET



The SPE 12E Super is a medium size Autoblaster machine suitable for all applications of floor surface preparation.

Mainly used for the preparation of concrete floors but equally effective on steel surfaces. The machine is electrically driven with forward and reverse drive being infinitely variable. The dust collection unit as with larger machines has continuous reverse air jet filtration cleaning. Recognised in the industry as the modern fast versatile environmental dust free means to dry abrasive cleaning and texturing of horizontal or slightly inclined surfaces. This eliminates mess normally associated with hand blasting. Leaves an ideal surface for coatings and overlays to be applied. Abrasive and debris is contained to prevent hazardous working and environmental pollution.

Features:

- Blast unit constructed of manganese steel.
- Dust collector fitted with integral compressor and reverse air jet pulsation system to allow continuous working
- Blasting width can be reduced for line removal and weld inspection.
- Self propelled variable speed drive allows complete operator control.
- Grill fitted into lower separator hopper unit assembly to eliminate foreign objects being allowed into the blastwheel causing damage.
- Capable of using upto S550 abrasive.
- Fully machined blastwheel support bearing assembly (eliminates bearing problems and automatically self aligns blastwheel components).
- Blastwheel can be rotated in both directions (Optional extra)
- Can be dismantled to pass through a 600mm access hole in storage tanks.

Applications:

- Removal of old coatings.
- Exposing aggregates.
- Providing non-slip surfaces.
- Removing rubber deposits.
- Laitence removal on new concrete floors.
- Light texturing for thin coatings.
- Steel preparation to SA3 standard.
- Storage tanks roofs and floors.
- Ship decks.
- Steel plates.
- Foot bridges.

Specification 12ES Blast Machine

Type	Electric 3 Phase
Part No	SPE 12ES
Std Motor Hp (higher optional available)	10
Voltage	380/415
Cycles	50/60
Cleaning Width (mm)	305
Machine Dimensions (mm)	
Width	480
Height	1200
Length	1180
Weight (kg)	320

Specification 12ES Dust Collector

Type	Electric 3 Phase
Part No.	SPE 12 D/C
Voltage	380/415
Cycles	50/60
Machine Dimensions (mm)	
Width	800
Height	1600
Length	1730
Weight (kg)	350



RECORD OF NOISE AND VIBRATION ASSESSMENT

Manufacturer: Blaster
 Type: SPE12ES
 Model No. Free Running
 Operation : Acoustic Associates
 HAV Note:

HAND-ARM VIBRATION

Frequency Weighted Energy Equivalent Accelerations ($a_{h,w}$)

Measurement Position	Acceleration (m/s^2)			
	X axis	Y axis	Z axis	Vector Sum
Handle	0.78	0.75	0.70	1.29

NOISE LEVELS

Sound Power Level (L_{WA})

L_{WA} at Octave Band Centre Frequency (Hz)								Sound Power Level L_{WA}
63	125	250	500	1000	2000	4000	8000	
61.6	73.4	86.3	105.7	94.7	94.4	84.1	74.2	106.3

Operator's Ear

$L_{Aeq,T}$ at Octave Band Centre Frequency (Hz)								Overall Level ($L_{Aeq,T}$)	L_{Peak} dB(C)
63	125	250	500	1000	2000	4000	8000		
40.8	56.3	72.7	88.8	79.7	74.4	64.9	53.8	88.9	101.3



WARRANTY

The standard warranty period of this equipment is **12 months** from the date below in accordance with the company Conditions of Sale (copy attached).

<i>Warranty start date:</i>	As despatch date
<i>Model:</i>	SPE12E Super
<i>Serial no:</i>	
<i>Customer name:</i>	
<i>Customer Address:</i>	

<i>Manufacturer:</i>	SPE International Ltd
	Honeyholes Lane
	Dunholme
	Lincoln
	LN2 3SU
	England
<i>telephone:</i>	+44 (0) 1673 860709
<i>fax:</i>	+44 (0) 1673 861119
<i>Email:</i>	sales@spe-int.com
<i>Web site:</i>	www.spe-int.com



WARRANTY

The standard warranty period of this equipment is **12 months** from the date below in accordance with the company Conditions of Sale (copy attached).

<i>Warranty start date:</i>	As despatch date
<i>Model:</i>	SPE12DC
<i>Serial no:</i>	
<i>Customer name:</i>	
<i>Customer Address:</i>	

<i>Manufacturer:</i>	SPE International Ltd
	Honeyholes Lane
	Dunholme
	Lincoln
	LN2 3SU
	England
<i>telephone:</i>	+44 (0) 1673 860709
<i>fax:</i>	+44 (0) 1673 861119
<i>Email:</i>	sales@spe-int.com
<i>Web site:</i>	www.spe-int.com



DECLARATION OF CONFORMITY

WE
SPE INTERNATIONAL LTD

OF
Honeyholes Lane
Dunholme
Lincoln
LN2 3SU

DECLARE that under our sole responsibility for the supply/manufacture of the product

(Description/name) **SPE12E Autoblast Machine**

(Model/type) **SPE12E Super**

to which this declaration relates is in conformity with the following standards and other normative documents following the provisions of Directive 2006/42/EC.

A handwritten signature in black ink, appearing to read 'B. Jacklin'.

.....
Brian Jacklin – Technical Manager
SPE INTERNATIONAL LTD

DECLARATION OF CONFORMITY

WE
SPE INTERNATIONAL LTD

OF
Honeyholes Lane
Dunholme
Lincoln
LN2 3SU

DECLARE that under our sole responsibility for the supply/manufacture of the product

(Description/name) **SPE12DC Dust Collector**

(Model/type) **SPE12DC**

to which this declaration relates is in conformity with the following standards and other normative documents following the provisions of Directive 2006/42/EC.



.....
Brian Jacklin – Technical Manager
SPE INTERNATIONAL LTD

The quotation overleaf and any order placed following such quotation are subject to the following conditions of sale in which SPE International Limited is referred to as the "Company".

1. Validity of quotation

No order received from a customer by the Company shall constitute a contract until accepted in writing by the Company.

2. Prices

Prices quoted by the Company are firm for 30 days only or until previously withdrawn. Unless otherwise stated all prices are exclusive of any applicable Value Added Tax for which the customer shall be additionally liable to the Company.

3. Delivery

Delivery periods and dates are given in good faith but are not the subject of any warranty or condition and time shall not be of the essence of the contract in these respects. No liability will attach to the Company if delivery periods or dates are not met for any reason whatsoever.

4. Payment

Save as may otherwise be agreed in writing the customer shall pay the price in full on or before the estimated delivery date whereupon the Company shall raise a receipted invoice. Each invoice includes an Overdue Account Levy of 5% of the total invoice value inclusive of VAT. Subject to payment in full being made on or before the due date a sum equal to the Overdue Account Levy shall be credited to the customer's account with the Company. Until such time as payment in full has been made the Company shall be under no obligation to allow or effect of any goods to the customer.

5. Warranty

The Company warrants that all goods supplied by it will correspond to their specifications and will be free from defects in materials or workmanship for a period of 12 months from the date of delivery. The Company's obligation in the event of a breach of this warranty is limited to the repair or replacement of any defective goods which shall be returned at the cost and expense of the customer to the Company. This warranty is given in lieu of all the other warranty or conditions expressed or implied (whether by statute or otherwise) and is subject to the following conditions:-

5.1 Claims must be notified in writing to the Company within seven days from the date of delivery or (where the defect is not apparent on reasonable inspection) as soon as practicable after discovery of the defect.

5.2 The Company shall be under no liability in respect of any defect in the goods arising from any drawing, design or specification supplied by the customer.

5.3 The Company shall be under no liability if the defect or failure in the reasonable opinion of the Company arises from wilful damage or misuse, negligence by the customer or any third party. Failure to follow the Company instructions, usage of non-recommended parts and materials, alteration or repair of the goods without the prior approval of the Company or non-recommended maintenance.

5.4 The Company shall be under no liability if the price for the goods has not been paid by the due date for payment.

5.5 The above warranty does not extend to:-

5.5.1 Parts, materials or equipment not manufactured by the company in respect of which the customer shall be entitled only to the benefit of any such warranty or guarantee as is given by the manufacturer to the Company.

5.5.2 Any component part of the goods or associated parts coming into contact with abrasive elements or dust within surface Preparation equipment.

5.5.3 Fair wear and tear of moving parts within the goods.

5.6 Except in the case of death or personal injury caused by the Company negligence, the Company shall not be liable for any consequential loss or damage (whether for loss of profit or otherwise) or other claims for consequential compensation.

6. Carriage

Packing, carriage and insurance charges in respect of delivery of the goods to the customer will be charged to the customer at cost to the company.

7. Damage in Transit

The company does not accept any liability for loss or damage to the goods while in transit to the customer.

8. Risk

The risk in the goods shall pass to the customer on delivery to the customer or (if earlier) when possession of the goods is taken by a carrier for delivery to the customer.

9. Force Majeure

The Company shall not be liable to the customer or be deemed to be in breach of any contract with the customer by reason of any delay in performing or any failure to perform any obligation of the Company obligation in relation to the goods if the delay or failure was due to force majeure or to any other cause beyond the Company's reasonable control.

10. Reservation of Title

The goods sold under these conditions shall remain the absolute property of the Company and legal title in the goods shall remain vested in the Company until payment in full of all amounts invoiced or due to the Company in respect of the goods. If the customer shall enter into liquidation have a winding up order made against it or have a Liquidator, receiver, administrator or administrator receiver shall be appointed over its assets, income or any part thereof before the property in the goods has passed in accordance with this condition the Company shall be entitled immediately after giving notice of its intention to repossess any goods to enter upon the premises of the customer with such transport as may be necessary and to repossess any goods to which it has title under this condition. No liquidator, receiver, administrator or administrative receiver of the customer shall have authority to sell goods to which the Company has title without the prior written consent of the Company.

11. Insolvency of Customer

If the customer being a body corporate, shall pass a resolution or suffer an order of the Court to be made for winding – up, or if a Receiver, Administrator or Administrative Receiver shall be appointed or, being an individual or partnership, shall suspend payment, propose or enter into any composition or arrangement with his or their creditors, or have a bankruptcy order made against him or them, then the Company shall have the right, without prejudice to any other contract with the customer, not to proceed further with the contract and shall be entitled to charge for work already carried out (whether completed or not) and for goods and materials already purchased for the customer such charge to be an immediate debt due from the customer.

12. Patent Rights, etc

The acceptance of a quotation includes the recognition by the customer of the Company under any patents, trademarks, registered designs or other intellectual property rights relating to the goods and the customer undertakes that patent numbers, trademarks or other trade markings on goods supplied shall not be obliterated, altered or defaced.

13. Applicable Law

These conditions shall be governed by and construed in accordance with English law and parties acknowledge and accept the exclusive jurisdiction of the English Courts.