



Bartell Morrison Inc.  
375 Annagem Blvd.,  
Mississauga, ON, Canada  
L5T 2A7  
Toll Free (N.A.): 1 866 501 1683  
Local: +1 905 364 4200  
Fax: +1 905 364 4201

# *PARTS* *MANUAL* **PREDATOR POLISHER/GRINDER**

P-3200



**ORIGINAL  
LANGUAGE**

Doc. # PB-B11025  
Orig. Rel. - 02/2011  
Curr. Rev. - 01  
Rev. Date - 07/2012

**Bartell Morrison Inc.**  
**375 Annagem Blvd.**  
**Mississauga, Ontario, Canada**  
**L5T 3A7**  
**Toll Free (N.A.): (866) 501-1683**  
**Phone: (905) 364-4200**  
**Facsimile: (905) 364-4201**  
**www.bartellmorrison.com**

**Bartell Morrison (USA) LLC**  
**25 Industrial Drive,**  
**Keyport, New Jersey, USA**  
**07735**  
**Toll Free: 888-999-1570**  
**Phone: (732) 566-5400**  
**Facsimile: (732) 566-5444**  
**www.bmiamerica.com**

**ORIGINAL LANGUAGE PARTS MANUAL FOR  
 PREDATOR POLISHER/GRINDER**

© 2010 *Bartell Morrison Inc.*

No part of this work may be reproduced or transmitted in any form or by any means, electronic or mechanical, including photocopying and recording, or by any information storage or retrieval system without the prior written permission of Bartell Morrison Inc. unless such copying is permitted by federal copyright laws.

Address inquiries or reference permissions care of:

Bartell Morrison Inc.,  
 375 Annagem Blvd.,  
 Mississauga, Ontario,  
 Canada, L5T 3A7

Revision	Date	Description	Approved by.
0	02/2011	Initial release	RL
01	07/2012	Drum assembly part number update.	AL

# PARTS BOOK

## P-3200

### TABLE OF CONTENTS

1. GRINDER FINAL ASSEMBLY	4
2. GRINDER HANDLE ASSEMBLY	6
3. CONTROLS & INVERTER BOX	8
4. DRUM DRIVE UNIT ASSEMBLY	10
5. DRUM ASSEMBLY	12
6. DRUM HOUSING ASSEMBLY	14
7. BELT TENSIONER ASSEMBLY	14
8. BEARING ASSEMBLY	16
9. CUTTER HEAD ASSEMBLIES	16
10. DRUM ASSEMBLY	18
11. CUTTER HEAD (INSERTED) ASSEMBLY	20
12. DRIVE PULLEY ASSEMBLY	22
13. IDLER PULLEY ASSEMBLY	22
14. FLOATING HEAD ASSEMBLY	24
15. RIGID HEAD ASSEMBLY	26
16. HOLDER ASSEMBLY	26

# PARTS LIST 1

## P-3200

### GRINDER FINAL ASSEMBLY

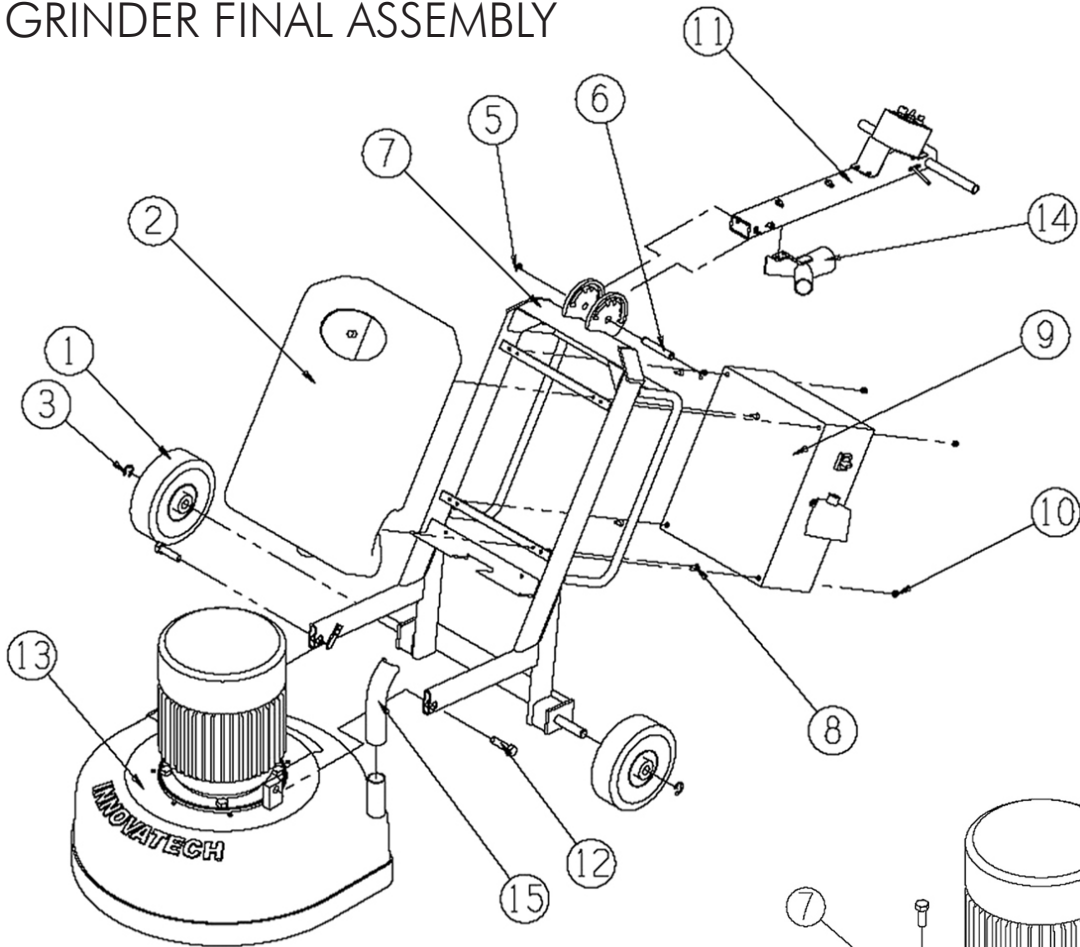

Fig. 1 - Grinder Assembly Complete

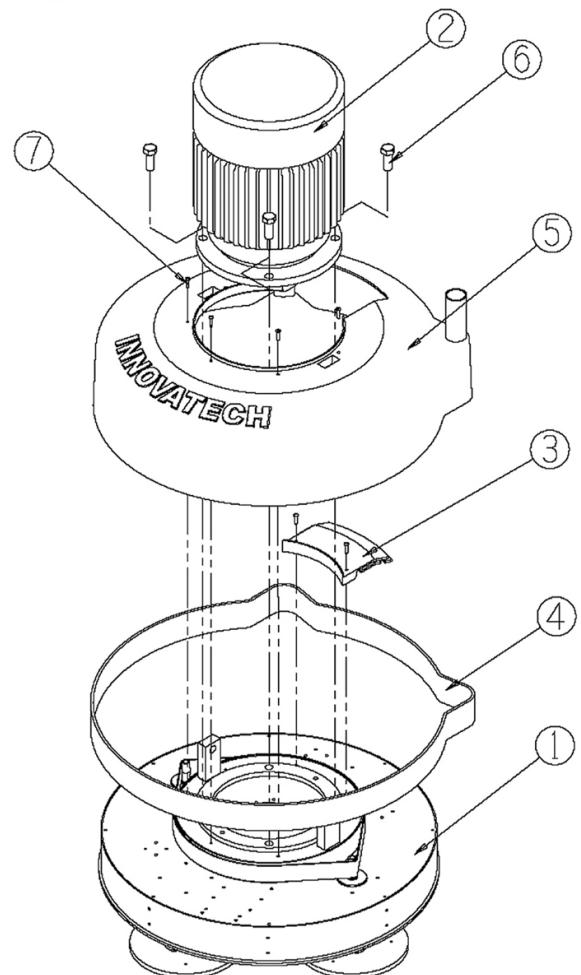

Fig. 2 - Grinder Head Assembly

# PARTS LIST 1

## P-3200

### GRINDER FINAL ASSEMBLY

Fig. 1 - Grinder Assembly Complete

ITEM NO.	PART NO.	DESCRIPTION	QTY.	REMARK
1	85069	WHEEL	2	
2	85212	WATER TANK	1	
3	10091	LYNCH PIN,3/16"	2	
5	10092	RETAINING CLIP,E-STYLE,7/8"	2	
6	85070	HANDLE HINGE PIN	1	
7	85301	FRAME	1	
8	10382	FHMS,5/16"-8X3/4"	4	
9	85213	INVERTER BOX	1	
10	10383	NUT,NYLOCK,3/8-16 THREADS	4	
11	85214	HANDLE ASSEMBLY	1	
12	10384	HANDLE ASSY	2	
13	85302	GRINDER HEAD	1	
14	85060	VACUUM TEE	1	
15	85059	VACUUM HOSE, 2"DIA	2	

### GRINDER HEAD

Fig. 2 - Grinder Head Assembly

ITEM NO.	PART NO.	DESCRIPTION	QTY.	REMARK
1	85303	DRUM DRIVE ASSEMBLY	1	
2	85215	MOTOR, 15HP, 1800RPM, 230/460V	1	
3	85216	GRINDER COVER	1	
4	85272	SPLASH GUARD	1	
5	85217	GRINDER COVER ASSEMBLY	1	
6	10399	HHCS, 3/4"-10X2"	4	
7	10098	HHCS, 1/4"-20X1-1/4"	7	

# PARTS LIST 2

## P-3200

### GRINDER HANDLE ASSEMBLY

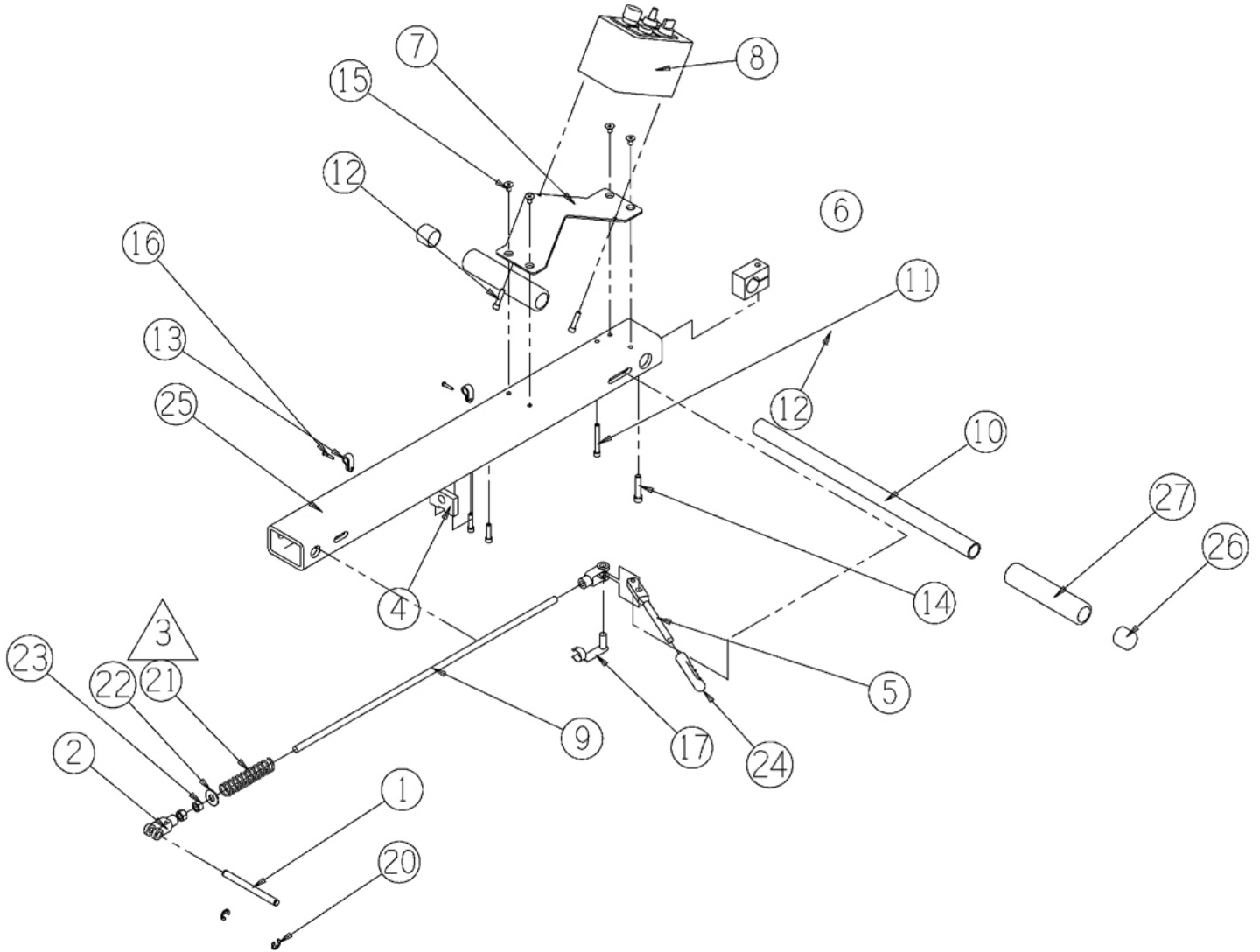

Fig. 3 - Grinder Handle Assembly

# PARTS LIST 2

## P-3200

### GRINDER HANDLE

Fig. 3 - Grinder Handle

ITEM NO.	PART NO.	DESCRIPTION	QTY.	REMARK
1	85218	HANDLE LOCK ROD	1	
2	85219	YOKE END	2	
3	85220	HANDLE	1	
4	85221	SPRING TENSION BLOCK	1	
5	85222	QUICK CHANGE LEVER	1	
6	85304	HANDLE GRIP CLAMP	1	
7	85063	CONTROL BOX MOUNT	1	
8	85157	[POWER] CONTROL BOX	1	
9	85223	THREADED ROD, 3/8"-24UNF x 2 3/4"	1	
10	85224	HANDLE GRIP	1	
11	10385	SHCS, 1/4"-20UNC x 2" LG	1	
12	10386	SHCS, 1/4"-20UNC x 1" LG	4	
13	85064	CABLE STRAP, 1/2"	2	
14	10387	SHCS, 3/8"-16UNC x 1-1/2" LG	1	
15	10388	FHSCS, 1/4"-20UNC x 1/2" LG	2	
16	10389	PHSCS, #8-32UNFX3/4"	1	
17	85274	CLEVIS SPRING PIN	1	
20	10390	RETAINING RING, E-STYLE, 3/8" DIA	1	
21	85225	SPRING, 7/8" OD x 4" LONG	1	
22	10905	WASHER, 3/8"	1	
23	10398	NUT, 3/8"-24UNF	3	
24	85275	GRIP COVER, 3/8" DIA	1	

# PARTS LIST 3

## P-3200

### CONTROLS & INVERTER BOX

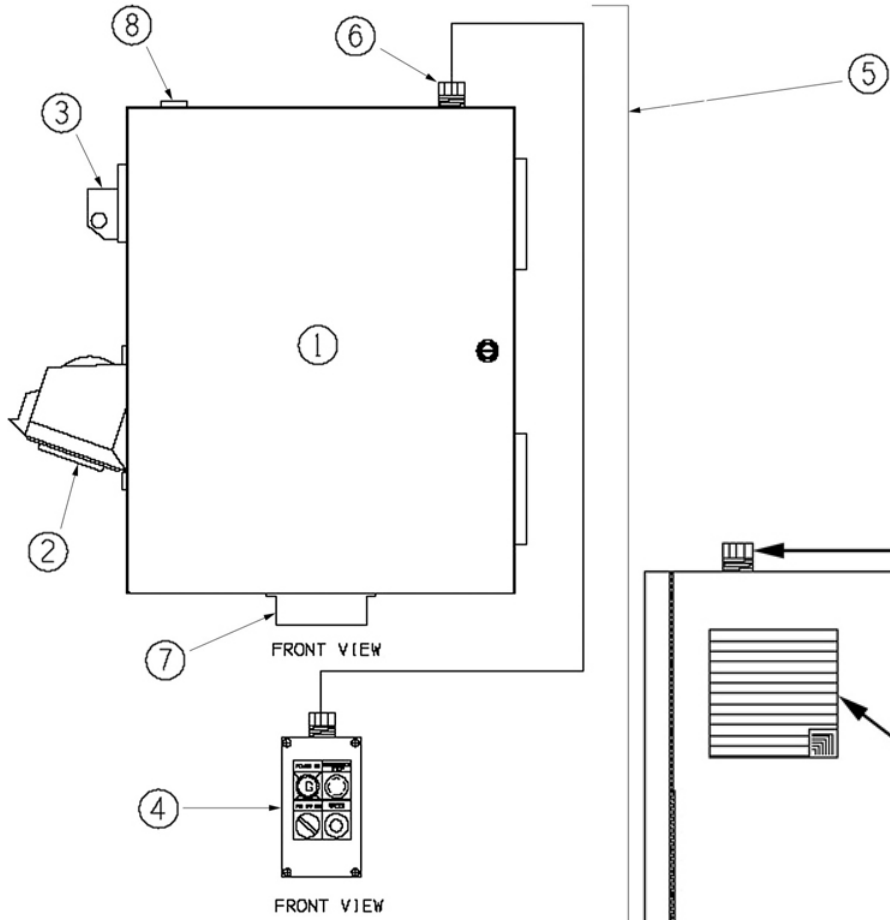

Fig. 4 - Controls & Inverter

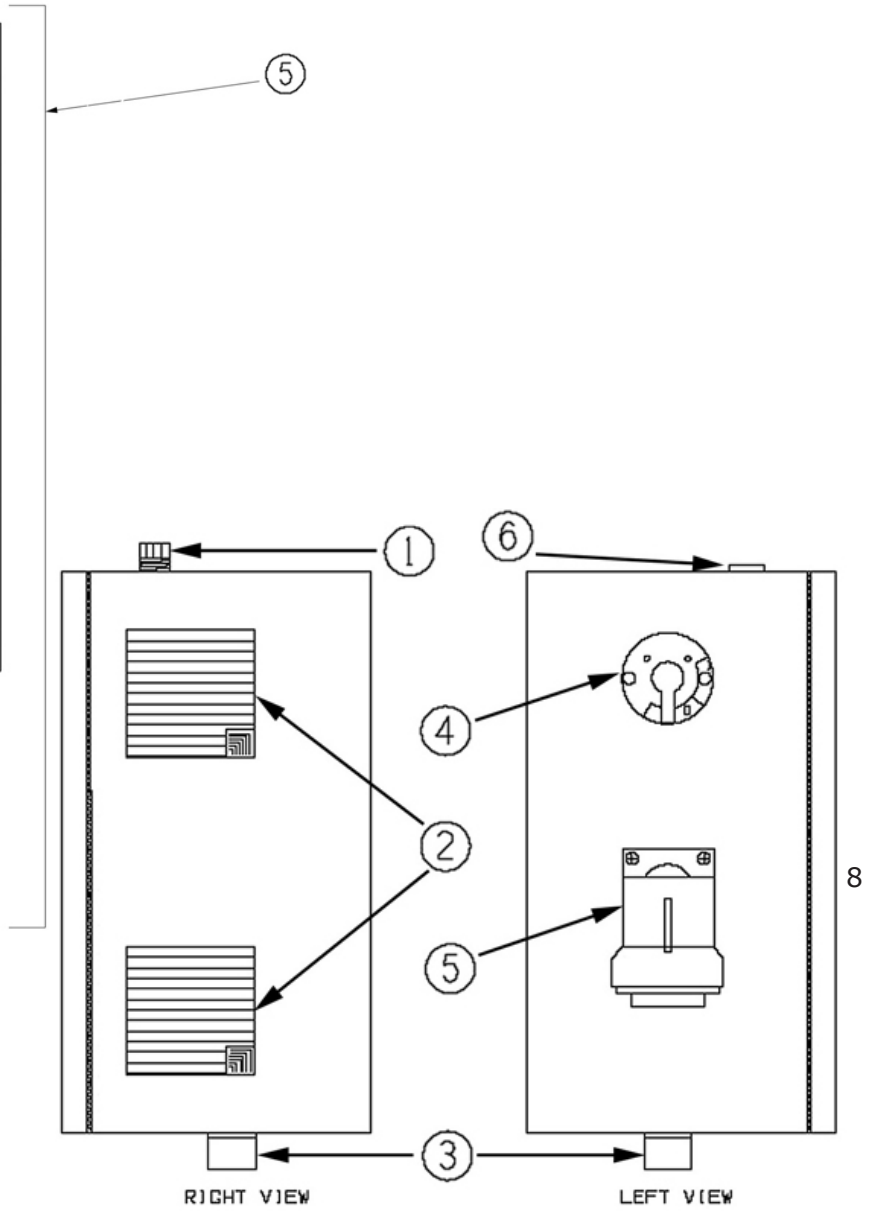

Fig. 5 - Inverter Side Views

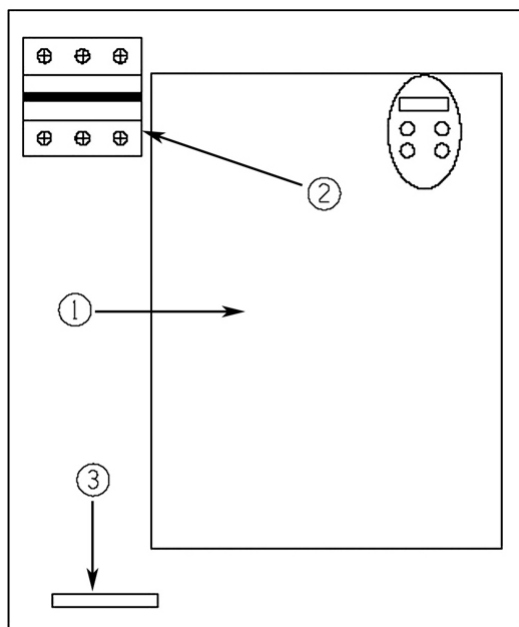

Fig. 6 - Inverter Backpan



# PARTS LIST 3

## P-3200

### CONTROLS AND INVERTER BOX

Fig. 4 - Controls & Inverter

ITEM NO.	PART NO.	DESCRIPTION	QTY.	REMARK
1	85213	STEEL ENCLOSURE	1	
2	85226	480 VOLT FLANGED INLET	1	
3	85227	ON/OFF SWITCH/CIRCUIT BREAKER	1	
4	85157	CONTROL BOX	1	
5	85228	COMPLETE INVERTER BOX W/ INVERTER AND CONTROL BOX	1	
6	85276	WIRE STRAIN RELIEF	1	
7	85162	QUICK DISCONNECT	1	
8	85159	HOUR METER	1	

### CONTROLS AND INVERTER BOX

Fig. 5 - Inverter Side Views

ITEM NO.	PART NO.	DESCRIPTION	QTY.	REMARK
1	85229	CONTROL BOX WIRE STRAIN RELIEF	1	
2	85230	COVER VENT	2	
3	85162	INVERTER TO MOTOR CONNECTION RING	1	
4	85227	ON/OFF SWITCH	1	
5	85226	480 VOLT FLANGED INLET	1	
6	85159	HOUR METER	1	

### INSIDE INVERTER BOX

Fig. 6 - Inverter Backpan

ITEM NO.	PART NO.	DESCRIPTION	QTY.	REMARK
1	85231	INVERTER	1	
2	85227	ON/OFF SWITCH/CIRCUIT BREAKER	1	
3	85305	BUS BAR	1	

# PARTS LIST 4

## P-3200

### DRUM DRIVE UNIT ASSEMBLY

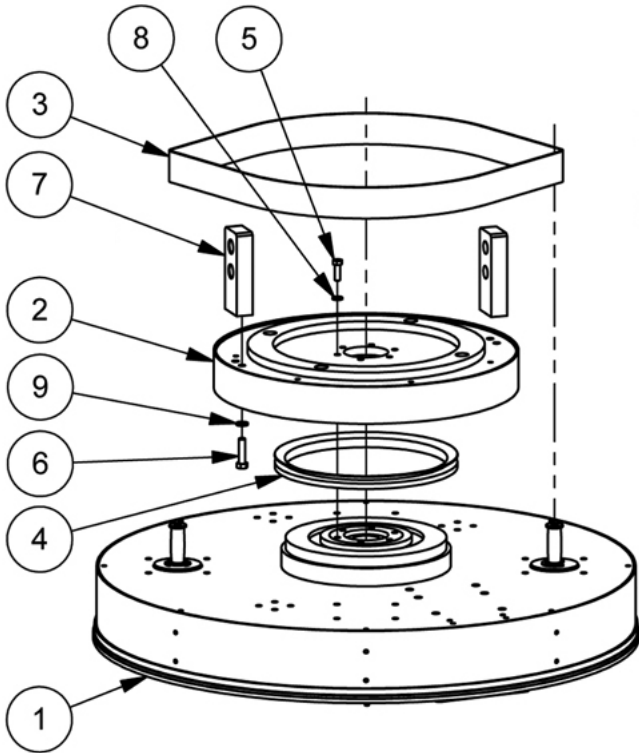
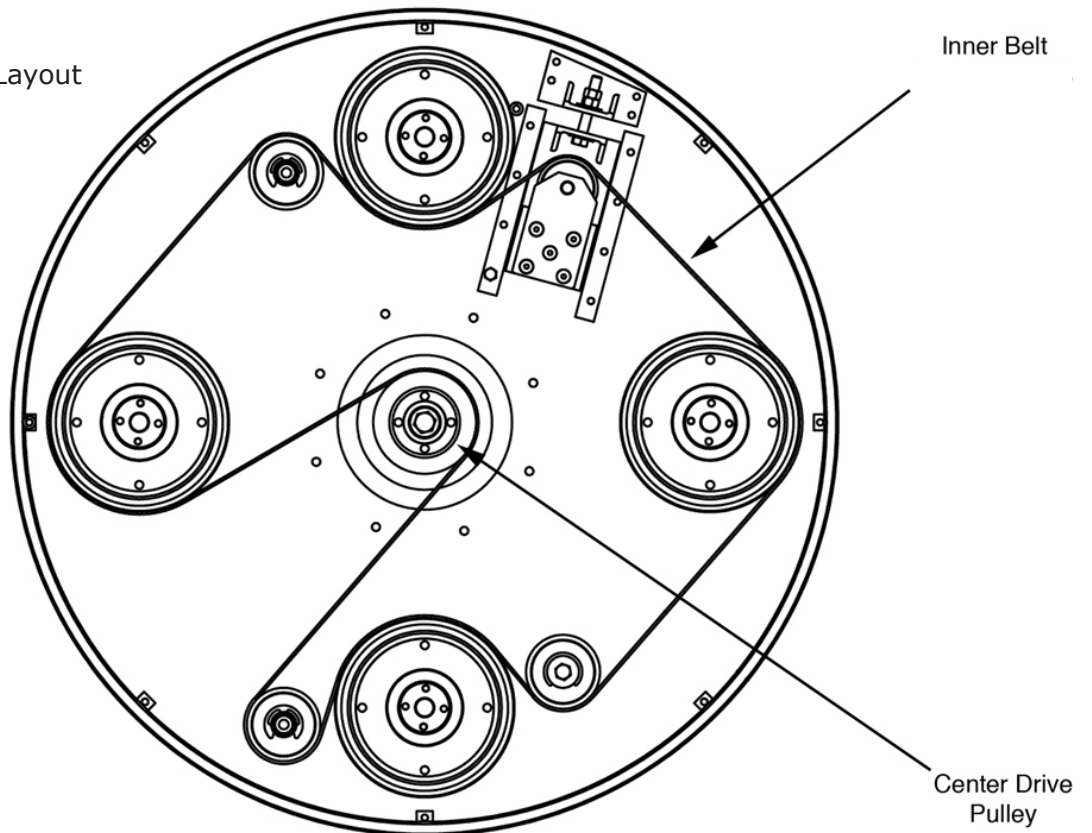

Fig. 7 - Drum Drive Unit Assembly

Fig. 8 - Drive Belt Routing Layout



ATTENTION: BELT'S GREY COLORED SIDE TO FACE TOWARD CENTER DRIVE PULLEY.

# PARTS LIST 4

## P-3200

### DRUM DRIVE UNIT

Fig. 7 - DRUM DRIVE UNIT ASSEMBLY

ITEM NO.	PART NO.	DESCRIPTION	QTY.	REMARK
1	85312	DRUM ASSEMBLY	1	
2	85232	MOTOR BASE ASSEMBLY	1	
3	85233	BELT, 1-7/8" W X 59-3/4" L	1	
4	10391	V-RING SEAL, 225ID X 25MM W	1	
5	10199	HHCS, 5/16"-18UNC x 1" LG	6	
6	10099	HHCS, 3/8"-16UNC x 1 1/2" LG	4	
7	85234	POST, 1 X 2 X 5" LONG	2	
8	10402	WASHER, FLAT, 5/16"	6	
9	10902	LOCKWASHER, 3/8"	4	



# PARTS LIST 5

## P-3200

### DRUM ASSEMBLY

Fig. 9 - DRUM ASSEMBLY

ITEM NO.	PART NO.	DESCRIPTION	QTY.	REMARK
1	85090	IDLER ASSEMBLY	3	
2	85235	TENSIONER SLIDING TRACK	2	
3	85236	BEARING ASSEMBLY	1	
4	10355	NUT, 3/8"-16UNC	2	
5	981120	WASHER (SAE), 3/8"	1	
6	85237	TENSIONER STATIONARY ANCHOR	1	
7	85238	TENSIONER SLIDING UNIT ASSEMBLY	1	
8	85239	PULLEY (CENTER DRIVE) ASEMBLY	1	
9	10521	LOCKWASHER, 1/4"	10	
10	50316	HHCS, 1/4"-20UNC x 1" LG	4	
11	10356	HHCS, 5/16"-18UNC x 3/4" LG	52	
12	30181	HHCS, 3/8"-16UNC x 3/4" LG	3	
13	10905	WASHER, 3/8"	6	
14	12418	NUT, 1/4"-20UNC	4	
15	85240	BELT	1	
16	85241	DRUM TOP/BOTTOM PLATE	1	
17	10963	HHCS, 1/4"-20UNC x 3/4" LG	6	
18	85242	CUTTER HEAD PULLEY ASSEMBLY (FLANGED)	1	
19	85243	CUTTER HEAD PULLEY ASSEMBLY (INSERTED)	1	
20	85244	CUTTER HEAD PULLEY ASSEMBLY - CAST UNIT	2	
21	10402	WASHER, FLAT, 3/8"	56	

# PARTS LIST 6

## P-3200

### DRUM HOUSING ASSEMBLY

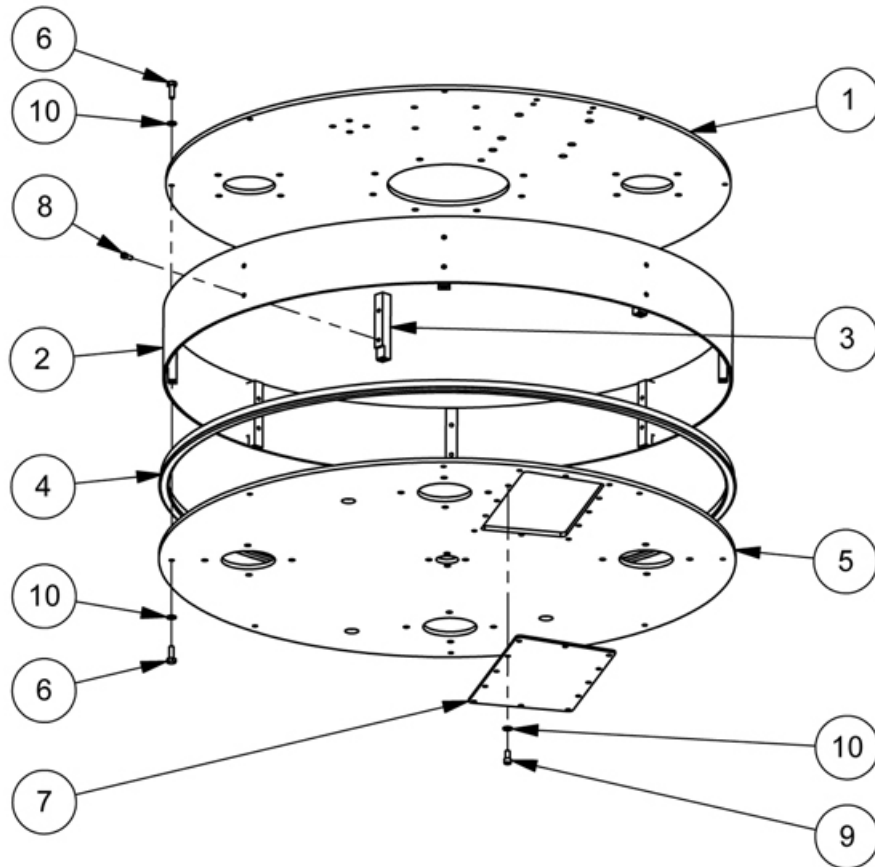

Fig. 10 - Drum Housing Assembly

### BELT TENSIONER ASSEMBLY

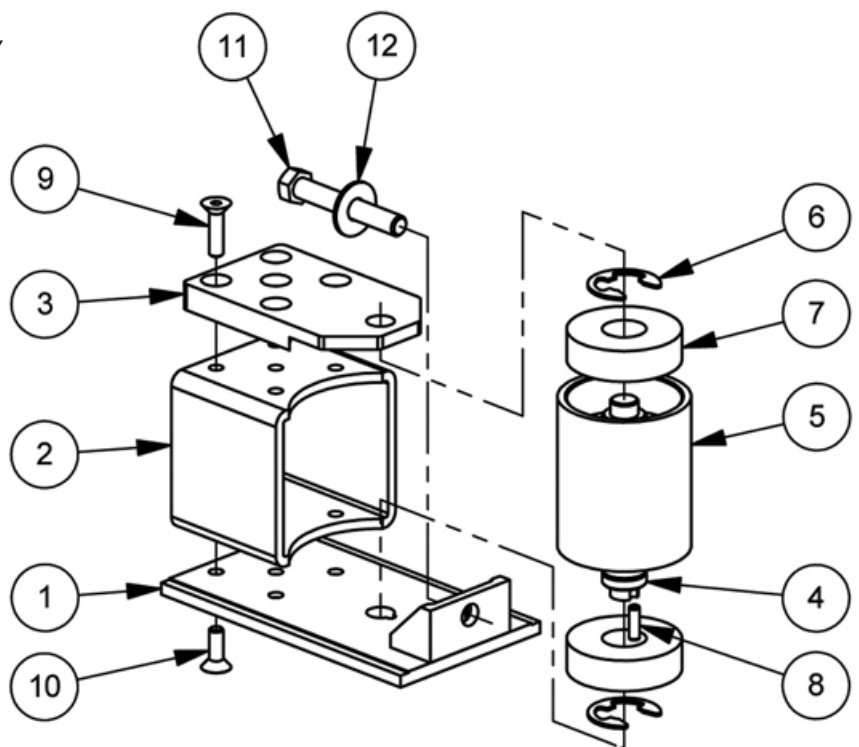

Fig. 11 - Belt Tensioner Assembly

# PARTS LIST 6

## P-3200

### DRUM ENVELOPE

Fig. 10 - DRUM ENVELOPE ASSEMBLY

ITEM NO.	PART NO.	DESCRIPTION	QTY.	REMARK
1	85245	DRUM TOP PLATE	1	
2	85246	DRUM SIDE WALL	1	
3	85099	SPACER BAR	8	
4	85128	SEAL (EDGE TRIM)	1	
5	85249	DRUM BOTTOM PLATE	1	
6	10963	HHCS, 1/4"-20UNC x 3/4" LG	16	
7	85250	COVER PLATE (TENSIONER ACCESS HOLE)	1	
8	10358	SHCS, #10-24UNC x 1/2" LG	16	
9	10359	SHCS, 1/4"-20UNC x 1/2" LG	12	
10	10521	LOCKWASHER, 1/4"	28	

### TENSION SLIDING UNIT

Fig. 11 - TENSION SLIDING UNIT ASSEMBLY

ITEM NO.	PART NO.	DESCRIPTION	QTY.	REMARK
1	85251	TENSIONER SLIDING BASE	1	
2	85252	TENSIONER HEIGHT SUPPORT BLOCK	1	
3	85253	TENSIONER TOP PLATE	1	
4	85133	SHAFT, 0.787 DIA	1	
5	85134	IDLER, 2-3/8"DIA X 7/8" DIA. SHAFT	1	
6	10092	RETAINING RING, E-STYLE, 7/8"DIA	2	
7	10362	BEARING, 20ID X 52OD X 15 H	2	
8	10363	DOWEL PIN, 3/6"DIA X 5/8 LONG	1	
9	10373	FHHCS, 1/4"-20UNC x 1" LG	5	
10	10361	FHCS, 1/4"-20UNC x 3/4" LG	5	
11	10260	HHCS, 3/8"-16UNC x 2 1/2" LG	1	
12	981120	WASHER, FLAT, SAE, 3/8"	1	

# PARTS LIST 7

## P-3200

### BEARING ASSEMBLY

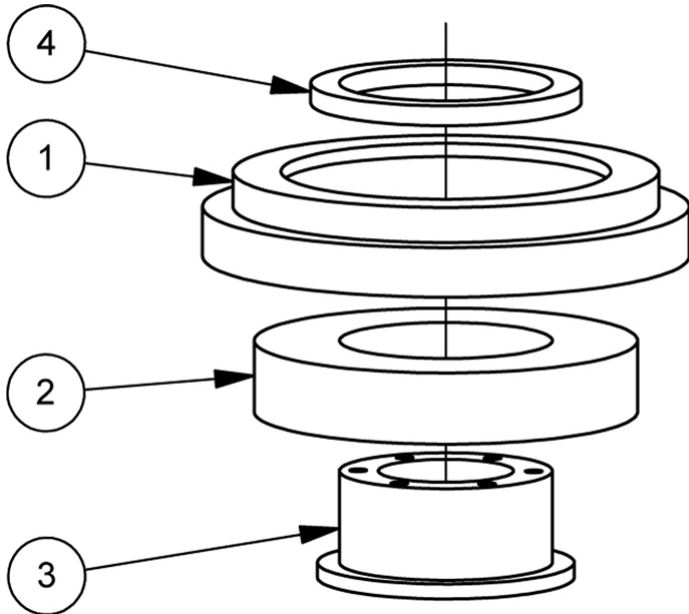

Fig. 12 - Bearing Assembly

### CUTTER HEAD ASSEMBLIES

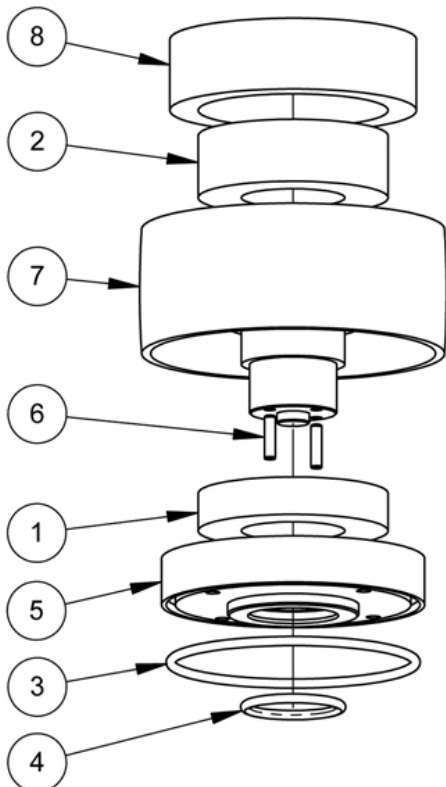

Fig. 13 - Cutter Head Pulley Assembly



# PARTS LIST 7

## P-3200

### BEARING ASSEMBLY

Fig. 12 - BEARING ASSEMBLY

ITEM NO.	PART NO.	DESCRIPTION	QTY.	REMARK
1	85254	BEARING HOUSING (ROTATING DRUM CONNECTION, OUTER HOUSING)	1	
2	10394	BEARING, 110ID X 200OD X 38H MM	1	
3	85255	BEARING HOUSING (ROTATING DRUM CONNECTION, INNER HOUSING)	1	
4	10395	SPACER RING, 4.332ID X 5.4OD X 3/8"	1	

### CUTTER HEAD PULLEY ASSEMBLY

Fig. 13 - CUTTER HEAD PULLEY ASSEMBLY

ITEM NO.	PART NO.	DESCRIPTION	QTY.	REMARK
1	10365	BEARING, 60ID X 110OD X 22H MM	1	
2	10366	BEARING, 60ID X 110OD X 36.5H MM	1	
3	10377	O-RING, 5-3/8"X5-3/4"ODX3/16"W	1	
4	10378	O-RING, 2"IDX2-3/8"ODX3/16"W	1	
5	85138	BEARING HOUSING (CUTTER HEAD, BOTTOM)	1	
6	10379	DOWEL, PIN, 1/4"DIA X 1"LONG	2	
7	85139	CUTTER HEAD PULLEY - CAST UNIT	1	
8	85256	BEARING HOUSING (CUTTER HEAD, TOP)	1	



# PARTS LIST 8

## P-3200

### CUTTER HEAD PULLEY ASSEMBLY

Fig. 14 - FLANGED TOP PULLEY

ITEM NO.	PART NO.	DESCRIPTION	QTY.	REMARK
1	85141	CUTTER HEAD PULLEY (W/FLANGED TOP PULLEY) - CAST UNIT	1	
2	10366	BEARING, 60ID X 110OD X 36.5H MM	1	
3	10365	BEARING, 60ID X 110OD X 22H MM	1	
4	10380	WOODRUFF KEY, 3/8" DIA X 1/16"THK	1	
5	10367	O-RING, 1-1/4"ID X 1-5/8"OD X 3/16"W	1	
6	10368	V-RING SEAL, 45ID X 9H MM	1	
7	10369	RETAINING RING, E-STYLE, 1"	1	
8	10377	O-RING, 5-3/8"ID X 5-3/4"OD X 3/16"W	2	
9	10378	O-RING, 2ID X 2-3/8OD X 3/16"W	1	
10	85138	BEARING HOUSING (CUTTER HEAD, BOTTOM)	1	
11	85257	BEARING HOUSING (CUTTER HEAD, W/ TOP PULLEY PROVISION)	1	
12	85143	COVER DISC (DUST SEAL), 2.75" DIA	1	
13	10379	DOWEL PIN, 1/4"DIA X 1"LONG	2	

# PARTS LIST 9

## P-3200

### CUTTER HEAD (INSERTED) ASSEMBLY

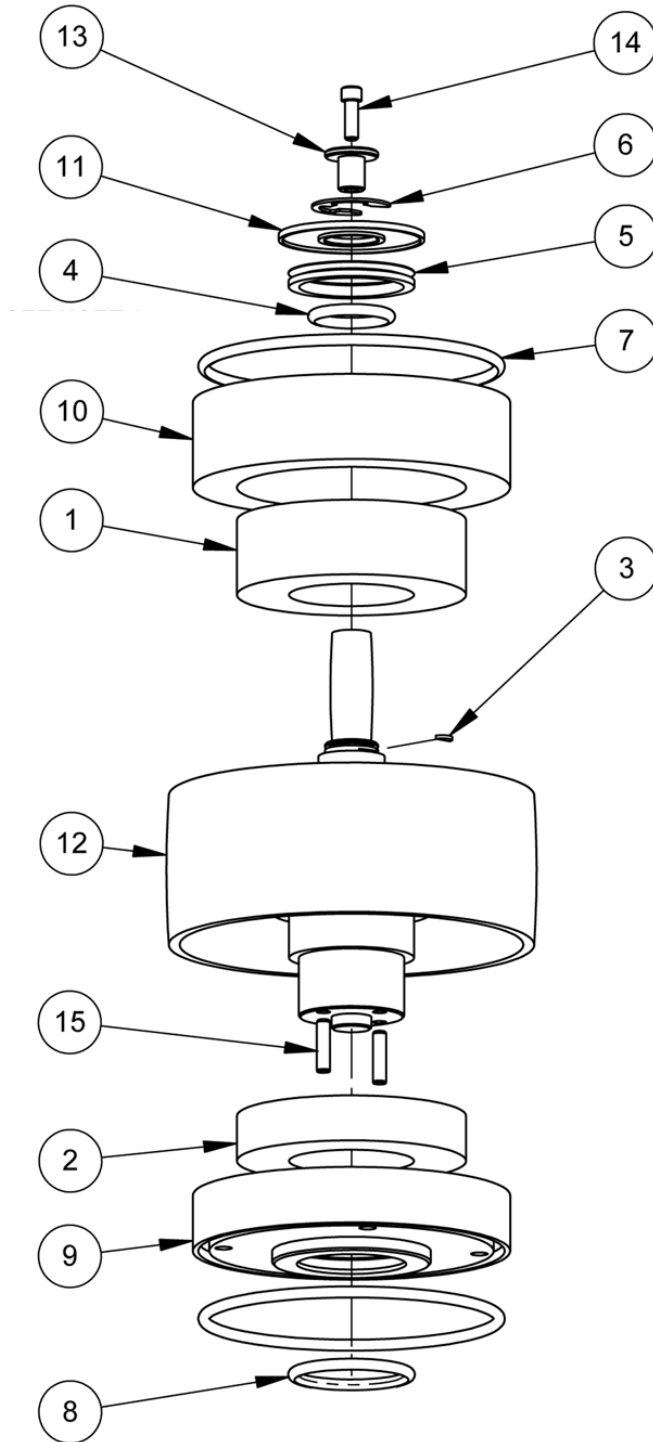

Fig. 15 - Cutter Head (Inserted) Assembly

# PARTS LIST 9

## P-3200

### CUTTER HEAD PULLEY ASSEMBLY

Fig. 15 - INSERT-FLANGED TOP PULLEY

ITEM NO.	PART NO.	DESCRIPTION	QTY.	REMARK
1	10366	BEARING, 60ID X 110OD X 36.5H MM	1	
2	10365	BEARING, 60ID X 110OD X 22H MM	1	
3	10380	WOODRUFF KEY, 3/8"DIA X 1/16"THK	1	
4	10367	O-RING, 1-1/4"ID X 1-5/8"OD X 3/16"W	1	
5	10368	V-RING SEAL, 45ID X 9H MM	1	
6	10369	RETAINING RING, E-STYLE, 1"	1	
7	10377	O-RING, 5-3/8"X5-3/4"ODX3/16"W	2	
8	10378	O-RING, 2IDX2-3/8"ODX3/16"W	1	
9	85138	BEARING HOUSING (CUTTER HEAD, BOTTOM)	1	
10	85257	BEARING HOUSING (CUTTER HEAD, W/ TOP PULLEY PROVISION)	1	
11	85143	COVER DISC (DUST SEAL, 2.75"DIA	1	
12	85144	CUTTER HEAD PULLEY (W/ NON-FLANGED TOP PULLEY) - CAST UNIT	1	
13	85145	FLANGE INSERT (FOR TOP DRIVE PULLEY)	1	
14	10213	SHCS, 1/4"-20X3/4"	1	
15	10379	DOWEL PIN, 1/4"DIA X1"LONG	2	

# PARTS LIST 10

## P-3200

### DRIVE PULLEY ASSEMBLY

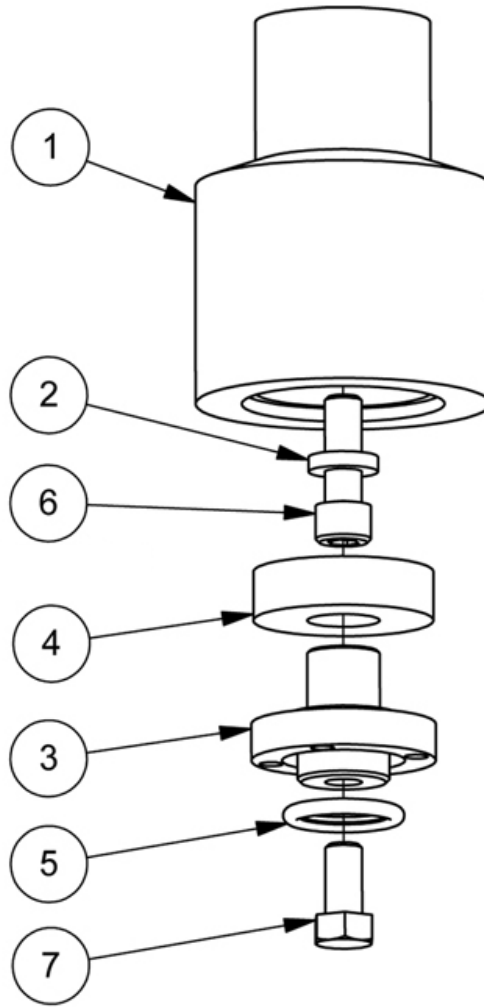

Fig. 16 - Drive Pulley Assembly

### IDLER PULLEY ASSEMBLY

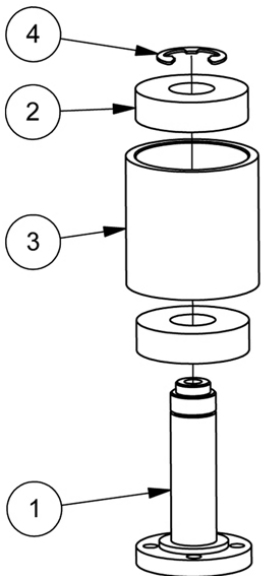

Fig. 17 - Idler Pulley Assembly

# PARTS LIST 10

## P-3200

### PULLEY ASSEMBLY

Fig. 16 - CENTER DRIVE

ITEM NO.	PART NO.	DESCRIPTION	QTY.	REMARK
1	85277	PULLEY (CENTER DRIVE), 4"DIA	1	
2	85206	WASHER, (CUSTOM MADE), 5ID X 0.94OD X 0.2" THK	1	
3	85146	SHAFT (CENTER DRIVE PULLEY SUPPORT)	1	
4	10370	BEARING, 25ID X 62OD X 17H MM	1	
5	10367	O-RING, 1-1/4ID X 1-5/8OD X 3/16"W	1	
6	10097	SHCS, 1/2-13UNC x 1 1/2" LG	1	
7	10371	HHCS, 1/2-13UNC x 1" LG	1	

### IDLER ASSEMBLY

Fig. 17 - IDLER ASSEMBLY

ITEM NO.	PART NO.	DESCRIPTION	QTY.	REMARK
1	85148	SHAFT (FOR MAIN DRIVE IDLER), 0.984"DIA	1	
2	10370	BEARING, 25ID X 62OD X 17H MM	2	
3	85149	IDLER (SLEEVE ROLLER), 2-7/8"DIA X 2-7/8"H	1	
4	10369	RETAINING RING, E-STYLE, 1"	1	

**PARTS LIST 11**  
**P-3200**

**FLOATING HEAD ASSEMBLY**

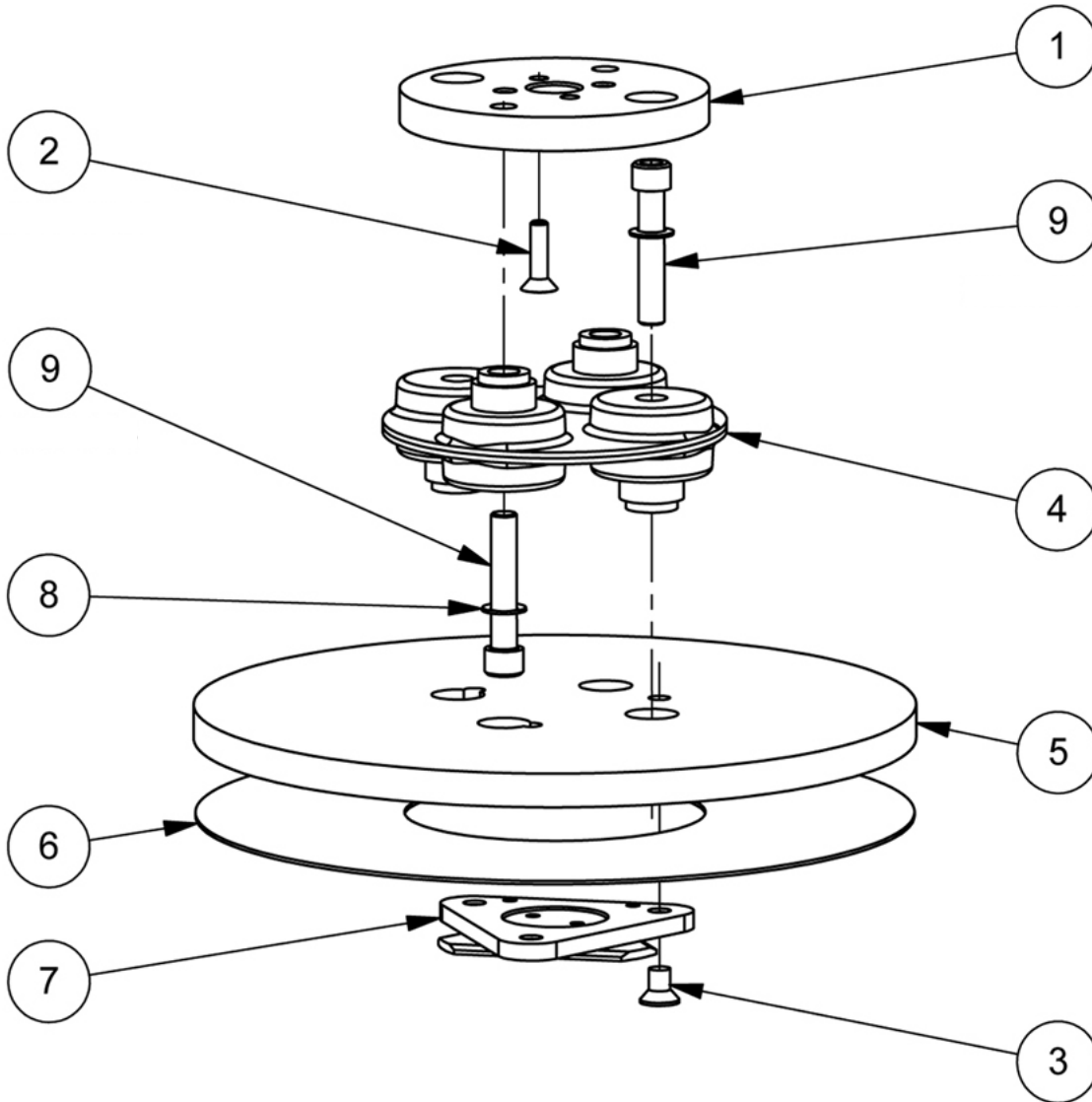

Fig. 18 - Floating Head Assembly



# PARTS LIST 11

## P-3200

### CUTTER HEAD FLOATING UNIT

Fig. 18 - CUTTER HEAD FLOATING UNIT ASSEMBLY

ITEM NO.	PART NO.	DESCRIPTION	QTY.	REMARK
1	85306	CUTTER HEAD FLOATING HEAD TOP PLATE	1	
2	10373	FHSCS, 1/4"-20X1"	2	
3	10374	FHSCS, 5/16-18X1/2"	3	
4	85307	FLEXIBLE COUPLING	1	
5	85308	CUTTER HEAD FLOATING HEAD BOTTOM PLATE	1	
6	85309	VELCRO MAT, 10-1/2"OD X 4-3/8"ID X 0.05"THK	1	
7	85262	CUTTER HEAD TRIANGLE HOLDER ASSEMBLY	1	
8	11442	WASHER, BELLEVILLE, 0.413ID X 0.630OD	4	
9	10371	SHCS, 3/8"-24X2"	4	

# PARTS LIST 12

## P-3200

### RIGID HEAD ASSEMBLY

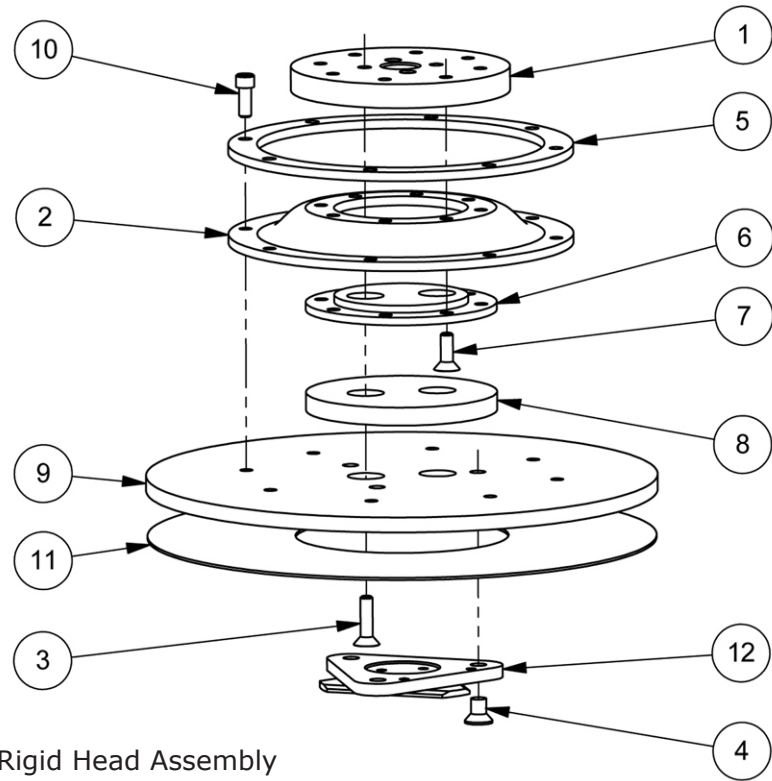

Fig. 19 - Rigid Head Assembly

### HOLDER ASSEMBLY

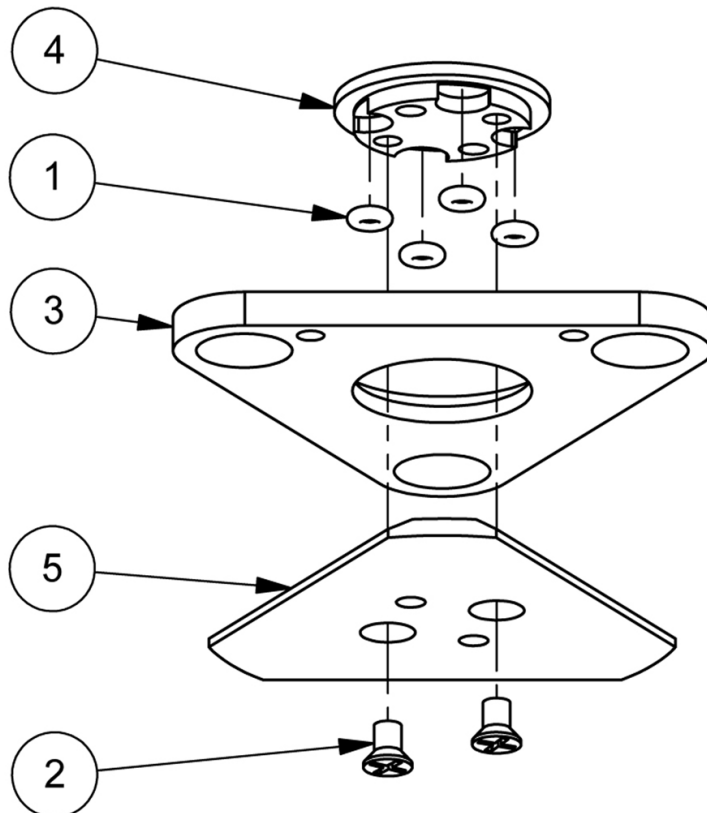

Fig. 20 - Holder Assembly

# PARTS LIST 12

## P-3200

### CUTTER HEAD RIGID HEAD UNIT

Fig. 19 - CUTTER HEAD RIGID HEAD UNIT ASSEMBLY

ITEM NO.	PART NO.	DESCRIPTION	QTY.	REMARK
1	85258	CUTTER RIGID HEAD TOP PLATE	1	
2	85310	CUTTER HEAD POLYCORD DISCS	1	
3	10373	FHSCS, 1/4"-20X1"	2	
4	10374	FHSCS, 5/16"-18X1/2"	3	
5	85259	CUTTER HEAD RIGID HEAD POLYCORD RING	1	
6	85260	CUTTER HEAD RIGID HEAD POLYCORD HUB	1	
7	10361	FHSCS, 1/4"-20X3/4"	8	
8	10396	CUTTER HEAD RIGID HEAD RUBBER SPRING DISC	1	
9	85261	CUTTER HEAD RIGID HEAD BOTTOM PLATE	1	
10	10397	SHCS, 1/4"-20X5/8"	8	
11	85309	VELCRO MAT, 10-1/2"OD X 4-3/8"ID X 0.05"THK	1	
12	85262	CUTTER HEAD TRIANGLE HOLDER ASSEMBLY	1	

### CUTTER HEAD TRIANGLE HOLDER ASSEMBLY

Fig. 20 - CUTTER HEAD TRIANGLE HOLDER ASSEMBLY

ITEM NO.	PART NO.	DESCRIPTION	QTY.	REMARK
1	10376	O-RING, 1/8"ID X 5/16"ODX3/32"W	4	
2	10381	FHSCS, #10-24X5/16"	2	
3	85263	TRIANGLE HOLDER BASE	1	
4	85155	TRIANGLE HOLDER CENTER ROTATOR	1	
5	85264	TRIANGLE HOLDER HOLD-DOWN	1	





**BARTELL MORRISON INC.**

375 Annagem Blvd.  
Mississauga, Ontario, Canada  
L5T3A7

Toll Free: 866-501-1683

Local: 905-364-4200

Fax: 905-364-4202

[www.bartellmorrison.com](http://www.bartellmorrison.com)

**BARTELL MORRISON (USA) LLC.**

25 Industrial Drive.  
Keyport, New Jersey, USA  
07735

Toll Free: 888-999-1570

Local: 732-566-5400

Fax: 732-566-5444

[www.bmiaamerica.com](http://www.bmiaamerica.com)

