

iQ Power Tools Repair Manual iQMS362

Table of Contents

IQMS362 DISASSEMBLY	3
Blade Removal	3
Blade Guard Removal	5
Arbor Assembly Removal	9
Control Module Disassembly	11
Saw Motor Disassembly and Removal	15
Saw Motor Stator Disassembly and Removal (Original Stator)	17
Saw Motor Stator Disassembly and Removal (Updated Stator)	19
Saw Mount Disassembly and Removal	23
Support Arm Disassembly and Removal	29
Support Arm Removal and Disassembly	31
Vacuum Motor Removal	33
Vacuum Brushes Removal (Original Version)	35
Vacuum Brushes Removal (Updated Version)	39
Vacuum Suction Inlet Removal	41
Filter Removal	43
Table Shock Removal	45
IQ362 ASSEMBLY	49
Table Shock Installation	49
Vacuum filter Installation	53
Vacuum suction Installation	55
Vacuum Motor brushes Installation/Replacement (Early Version)	57
Vacuum Brushes Installation (New Version)	61
Support Arm Assembly and Installation	63
Pivot Arm Assembly and Installation	67
Saw Motor Armature Installation	75
Saw Motor Stator Assembly (Original Version)	77
SAW STATOR ASSEMBLY AND INSTALLATION	81
Control Module Installation and Assembly	85
Arbor Assembly Installation	89
Guard Guide Rail Assembly and Installation	93
Blade Installation	99
IQMS362 ADJUSTMENTS	101
Sliding Table Upper and Lower Roller Check and Adjustments	101
Sliding Table Travel Check and Adjustments	109
Pivot Arm Squareness Check and Adjustments	115
Table Louver and Vacuum Suction Clearance Check and Adjustment	121
Vacuum and Seal Check	123
WIRING DIAGRAM	125

iQMS362 DISASSEMBLY

Blade Removal

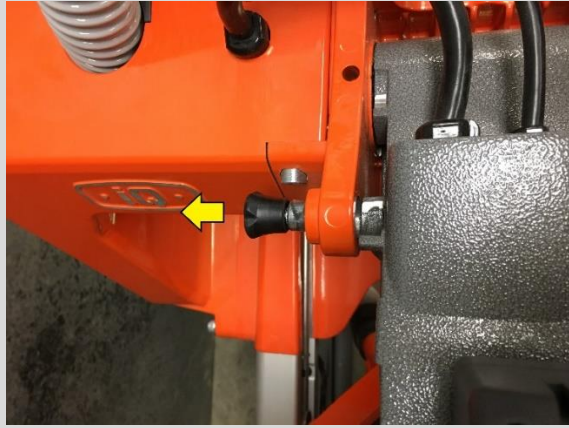

1. Raise the gear housing by pulling out the lock pin while pushing down on the gear housing.



2. Using the Allen wrench provided, loosen the 2 outside blade guard screws



3. Lift the outside blade guard to expose the blade and the blade hex screw.



4. Depress the spindle lock button on the motor



5. loosen hex nut using the Allen wrench provided.
6. Remove the blade hex nut and outer blade flange and the blade.

Blade Guard Removal



1. Disconnect the vacuum hose



2. Remove the outer blade guard cover



3. Remove the inner blade flange

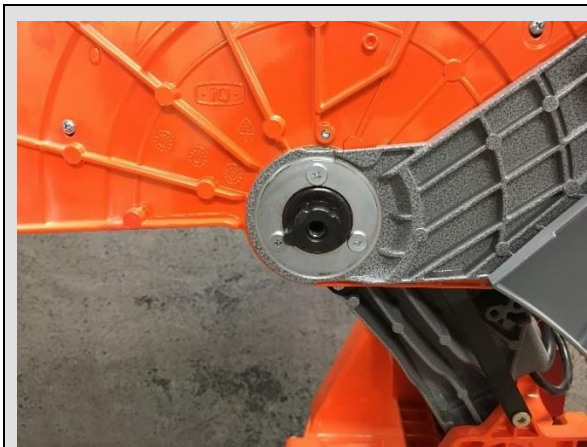

4. Remove the blade shaft assembly ring retaining screws



5. and remove the inner dust guard retaining plate



6. Remove the inner dust guard

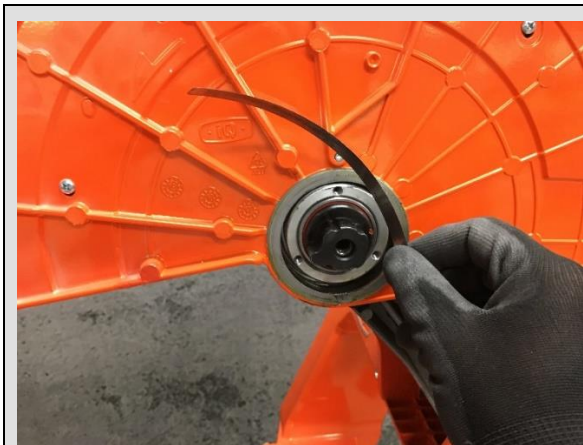

7. NOTE: Beware of 2 wear washers between inner dust guard and inner blade guard



8. Remove the blade guard link arm screw.



9. Rotate the inner blade guard 90 degrees counter clockwise (left) to clear the inner blade guard guide rail.

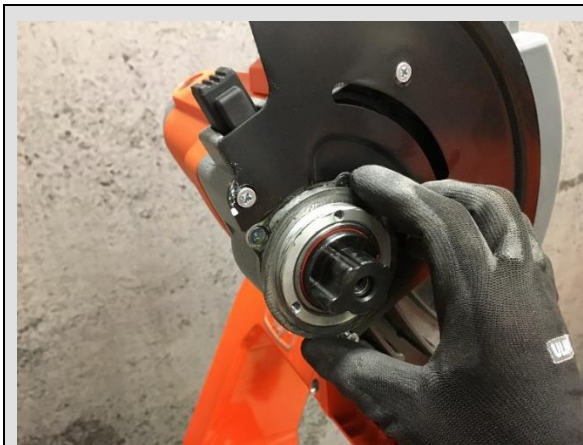

10. Remove the inner washer (spacer)



11. Remove the blade guard guide rail blade guard guide rail by removing the retaining screws.

Arbor Assembly Removal

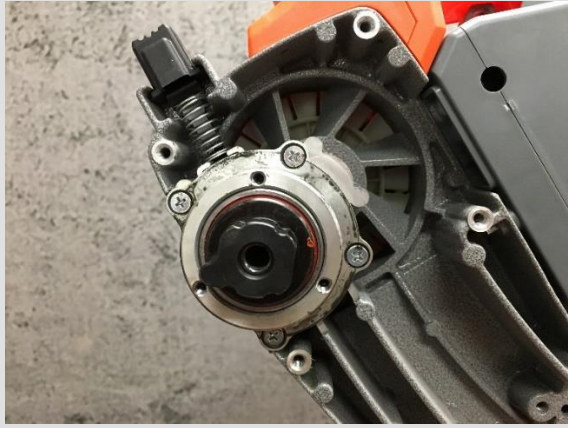

1. Remove the blade shaft assembly retaining screws

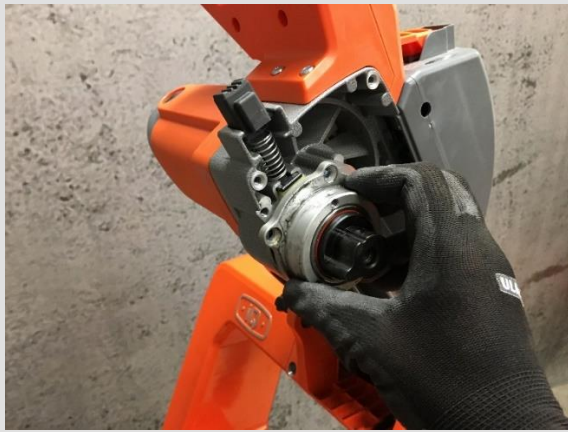

2. Rotate the blade shaft assembly lock assembly left to right while pulling to remove from the housing.



3. Remove the Spindle Lock, button and compression spring

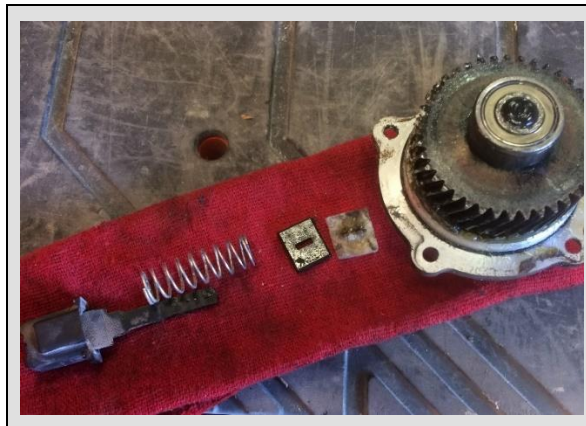

NOTE: Once removed you should have:

- The spindle lock and button
- Compression spring
- Seal pad
- Felt seal
- Blade shaft assembly

Control Module Disassembly



1. Remove Control Module Retaining Screws

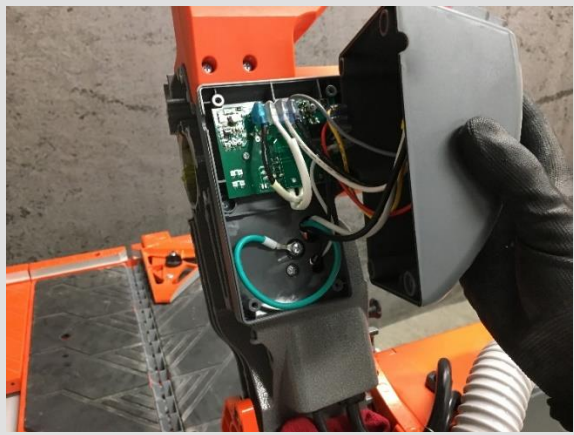

2. Lift cover and disconnect electrical wires from the Circuit Board



3. Disconnect all the connections on the Circuit board



4. Remove the motor power leads from the On/Off switch (normally Black and White)

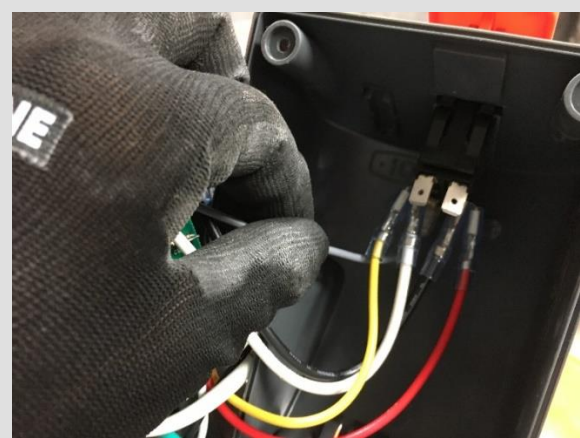

5. Disconnect the grey wire from the On/Off switch



6. Remove the control module cover.

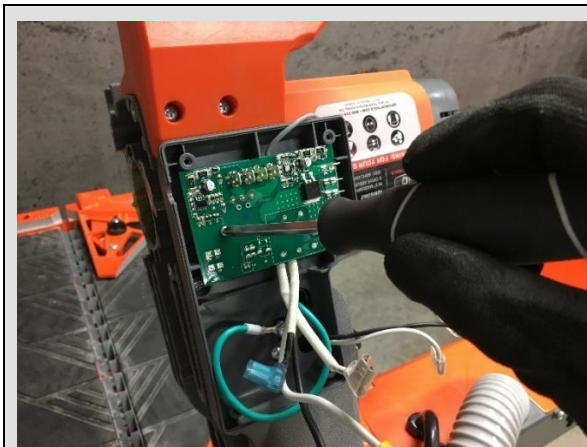

7. Remove the Circuit Board retaining screw and remove the circuit board.



8. Remove Ground Wire Retaining Screw



9. Remove Control Module mounting screws

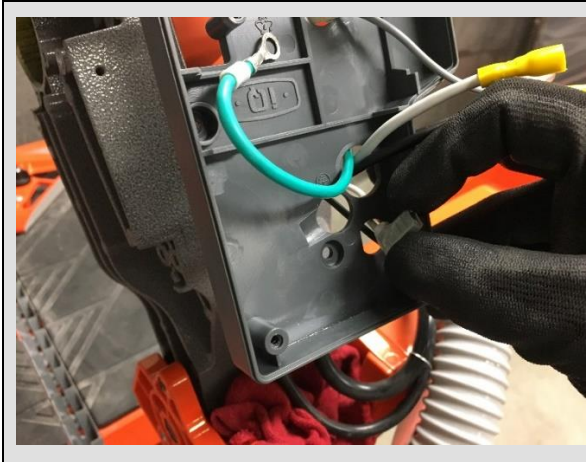

10. Route the wires through the opening at the bottom of the base of the control module

Saw Motor Disassembly and Removal



1. Lower and lock the gear housing in the down (Cutting) position.



2. Remove Saw Motor brush covers



3. Remove Saw Motor Brushes



4. Remove Saw Motor retaining screws
NOTE: There are a total of 4 screws, one on each corner.



5. Remove the saw motor housing assembly with the stator



6. Remove the armature from the gear housing

Saw Motor Stator Disassembly and Removal (Original Stator)



1. Remove saw motor end cover screws and remove end cover



2. Disconnect saw motor brush connectors



3. Route the stator wires through the saw motor housing assembly



4. Loosen and remove the saw motor stator retaining screws

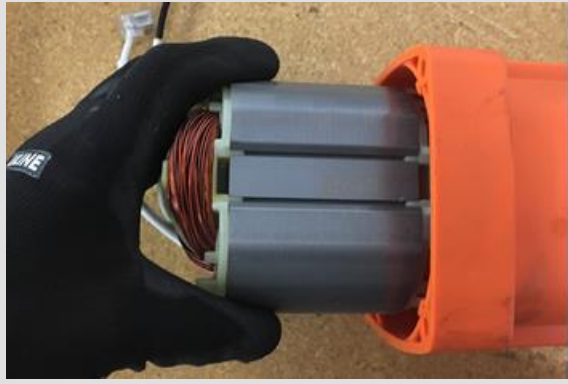

5. Remove the saw motor stator



6. Remove the saw motor brush wire and connector



7. Remove the rubber bushing

Saw Motor Stator Disassembly and Removal (Updated Stator)



1. Remove the saw motor end cover retaining screws



2. Remove the saw motor end cover

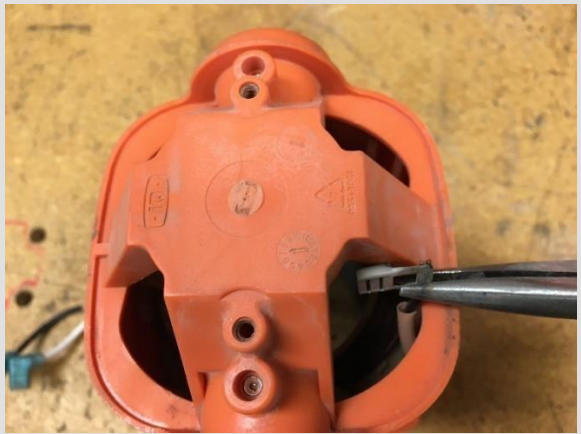

3. Disconnect the stator brush connectors from the brush connectors



4. Route the stator conductors through the saw motor stator case



5. Remove the stator retaining screws



6. Remove the stator from the saw motor case



7. Remove the rubber bushing



8. Check the saw motor case to ensure the armature bearing bushing has been removed

Saw Mount Disassembly and Removal

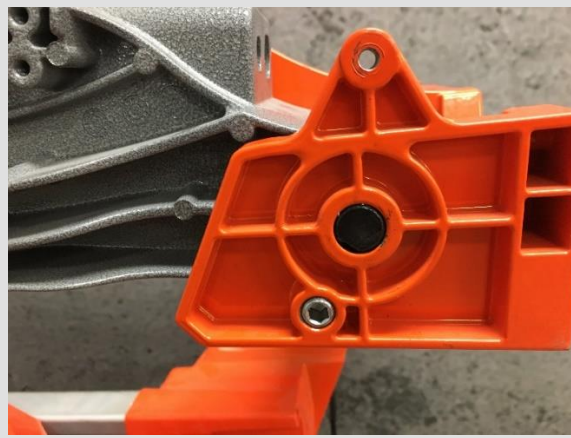





1. Remove the motor pivot mount lock nut



2. Raise the gear housing to the open position



3. Remove the power cord clamp from beneath the gear housing

	<p>4. Lower and gear housing to the cutting position</p>
	<p>5. Using strain relief grommet pliers, compress the strain cord grip and pull straight out to remove.</p>
	<p>6. pull the wires out of the gear housing</p>
	<p>7. Remove the cord grip from the power cords</p>



8. Remove the support arm cover retaining screws

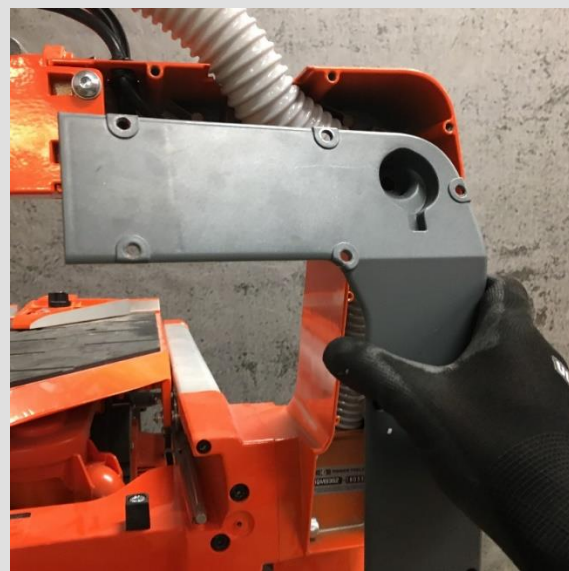

9. Remove the support arm cover



10. Remove the saw motor power cable cord clamp



11. Disconnect the vacuum hose end fitting from the vacuum

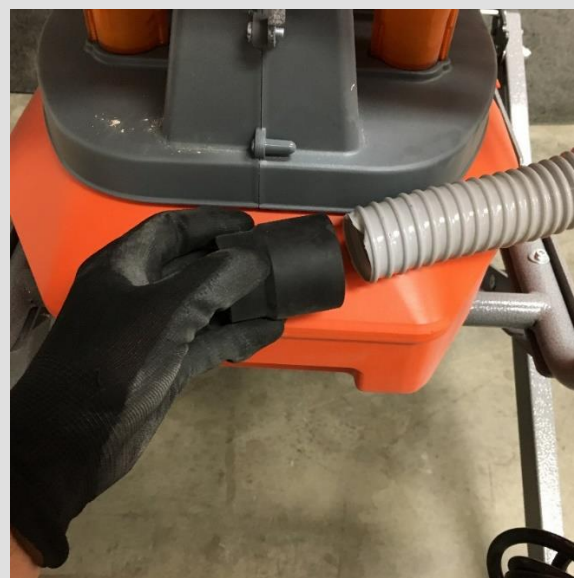

12. Remove the vacuum hose end fitting from the hose



13. Remove the vacuum hose through the support arm



14. Remove the vacuum motor power cord clamp

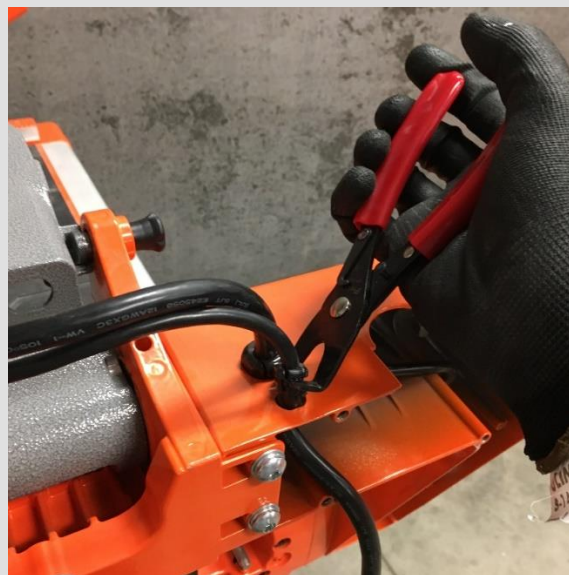

15. Using strain relief pliers, remove the cord grip.

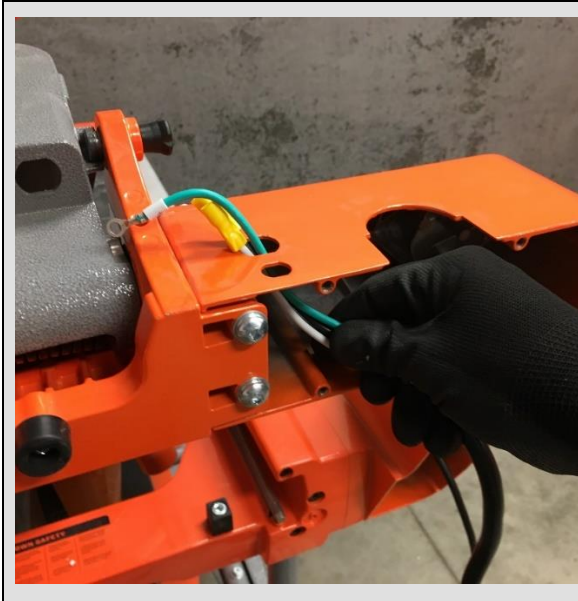

16. Route the saw motor power cable through the opening.

Support Arm Disassembly and Removal



1. Raise the gear housing fully to relieve tension on the spring.



2. Loosen the adjustment screw to remove tension from the arm.



3. Remove the support arm screws



4. Hold the support arm while loosening the adjustment screw until the support arm is fully removed.



5. Lay the gear housing and motor pivot mount on a work bench so the pin has room beneath it. Tap the pin out



6. Remove the gear housing from the pivot mount assembly



7. Remove the bushing from inside the spring coil.

Support Arm Removal and Disassembly



1. Disconnect the vacuum power cord.



2. Remove the support arm hex head screws and remove the support arm



3. Remove the vacuum cord clamp

Vacuum Motor Removal



1. Unlock sliding table



2. Remove sliding table



3. Remove vacuum power cord clamps



4. Unscrew vacuum screws and remove vacuum

Vacuum Brushes Removal (Original Version)



1. Unscrew vacuum motor cover screws



2. Lift vacuum motor cover



3. Pry plastic outer cover over tabs



4. Remove plastic cover

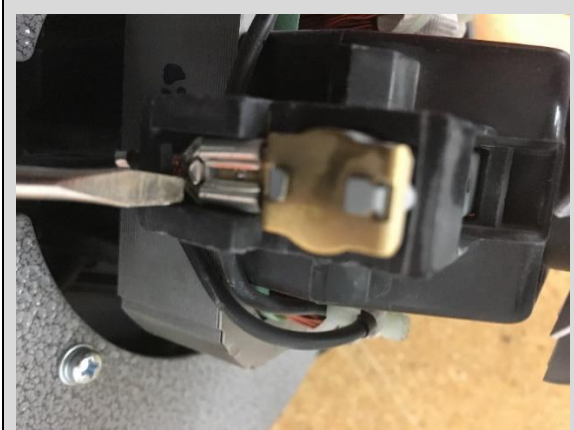

5. Depress vacuum motor brush connector with a small screw driver



6. Slide connector out

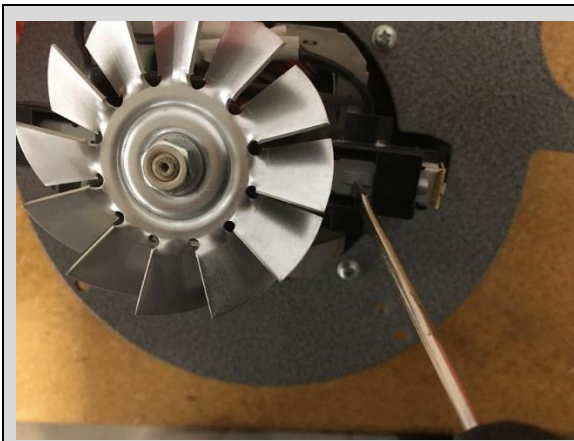

7. Depress the locking tab on the side of the vacuum motor brush housing.



8. With a set of pliers, grab the flat side of the brush case. The brush case will require some force to pull out



9. Remove the brush case with carbon brush completely

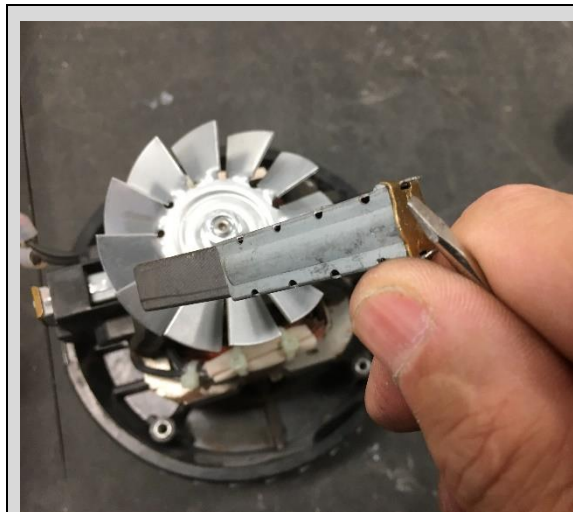

10. Lift the tabs that are securing the brush connector to the brush case



11. Separate the brush connector from the brush case



12. Pull the brush from the brush case.

Vacuum Brushes Removal (Updated Version)



1. Remove vacuum motor end cap.



2. Lift the brush holders up to gain access to the brushes.

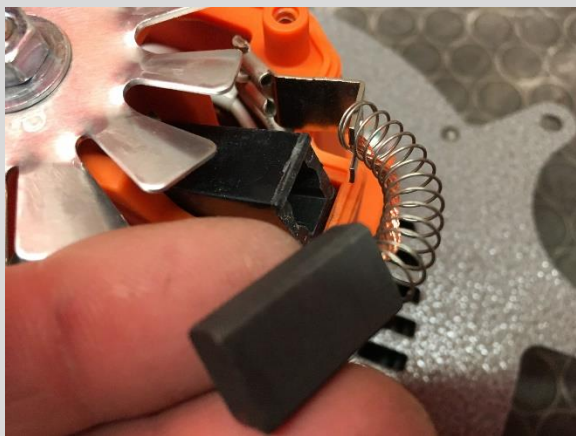

3. Remove the brushes from the brush holders.

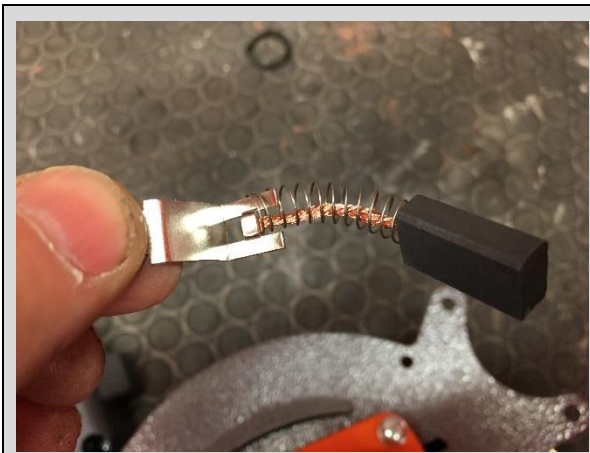

4. Disconnect the brushes and replace.

Vacuum Suction Inlet Removal



1. Secure the hex nut while loosening the Allen screw. Once loose, completely remove the screw.



2. Tighten the nut and screw so that the screw spins freely with little play.

Filter Removal



1. Agitate the filter by spinning it 3 times



2. Remove the filter spin knob



3. Remove the filter cover retaining screws and remove cover



4. Remove the filter



5. Check the filter tab

Table Shock Removal



1. Remove the iQMS362 lower frame assembly from the stand assembly

Disassembly order is

1. Stand assembly locking mechanism area
2. Side opposite of locking mechanism
3. Stand assembly crossmember







2. Remove the stand assembly end cap



3. Remove the locking mechanism retaining nut



4. You should have
 - a. A nylock nut
 - b. A flat washer
 - c. A plastic washer

	<p>5. Remove the retaining nut from the side opposite the locking mechanism</p>
	<p>6. Remove the upper cross arm</p>
	<p>7. Using the upper cross arm as leverage, pull the upper cross arm locking mechanism bolt from the upper shock retainer</p>
	<p>8. Remove the stand assembly cross connect bolt</p>



9. Remove the cross connect bushing. Pay attention to how it is installed





10. Pull the shock out







11. Remove the 2 spacers for the upper shock mount from inside the arm

IQ362 ASSEMBLY

Table Shock Installation

	1.
	2. Slide the shock into the arm with the cylinder in first followed by the extension rod.
	3. Insert the spacers so 1 is on either side of the shock extension rod
	4. The spacer – shock extension – spacer should be visible from the slot

	<p>5. Verify the upper shock bolt is tightly installed on the upper support arm and 2 flat washers are in place after the locking mechanism</p>
	<p>6. Slide the upper support arm upper shock bolt thru the slot going thru the spacer – shock extension -spacer</p>
	<p>7. Install the plastic washer, followed by the flat washer then by the nylock nut</p>
	<p>8. Loosely tighten the locking mechanism retaining nut</p>



9. Install the cross-member spacer.
Verify the cavity is facing outward.



10. Align the lower shock mount hole with the cross connect

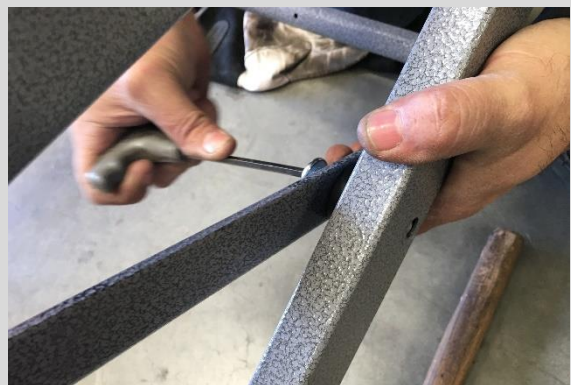

11. Using an Allen wrench, insert the cross connect bolt thru the inner cross member – spacer – outer cross member.



12. Remove the upper cross arm



13. Remove the retaining nut from the side opposite the locking mechanism



14.

Vacuum filter Installation



1. Apply lubricant and Insert filter in filter housing

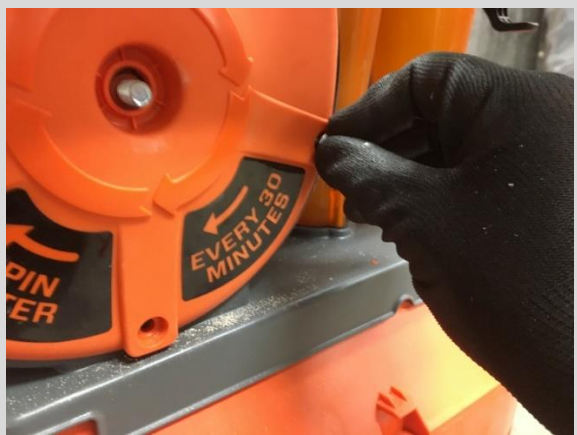

2. Install filter housing Cover



3. Install filter handle

Vacuum suction Installation



1. Insert screws and tighten jamb nut on screw until tight but both screw and nut spins freely.



2. Mount vacuum inlet on top of vacuum and screw into vacuum assembly. Ensure there is enough space, so the rolling table will clear.

Vacuum Motor brushes Installation/Replacement (Early Version)

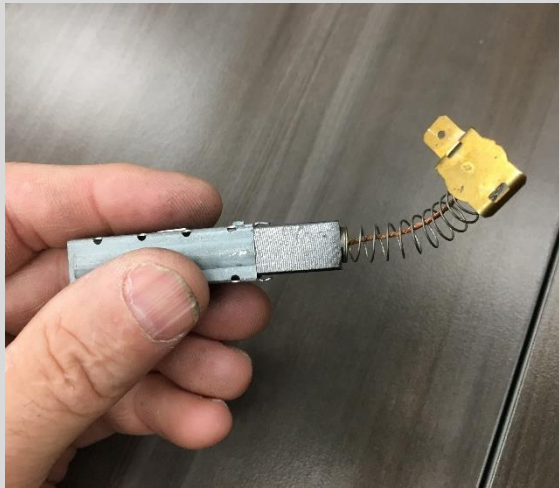

1. Slide the carbon brush into the metal case

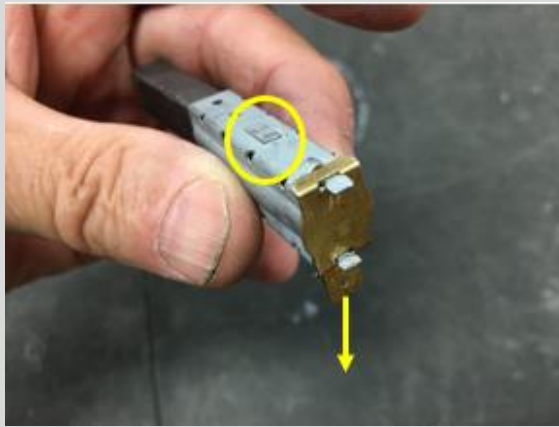

2. With the locking tab facing UP, place the brush connector on to the case with the connection facing opposite the locking tab

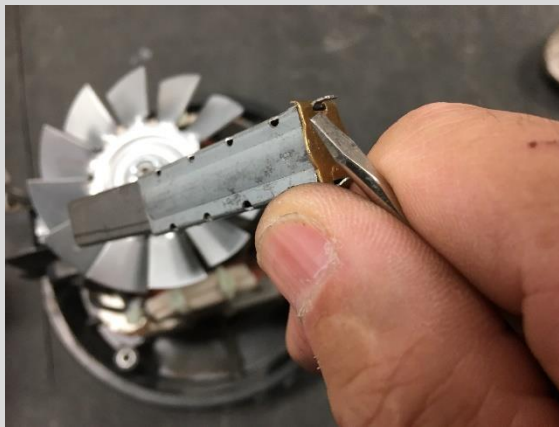

3. Lock the brush connector onto the case by folding the locking ears onto the connector

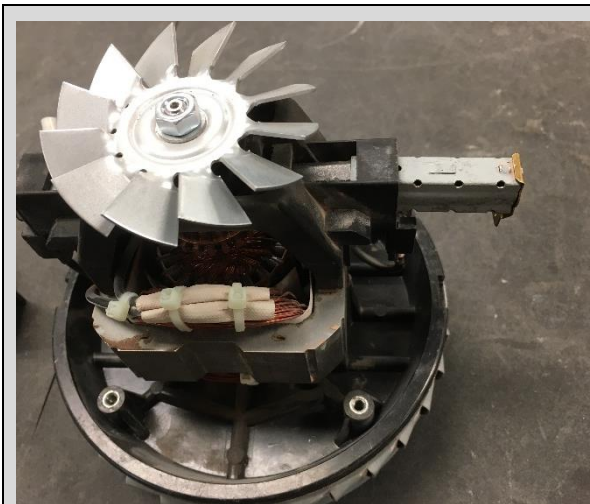

4. Slide the case with brush into the vacuum motor



5. Slide the vacuum motor brush until the locking tab is in the locked position.



6. Slide the vacuum motor brush connection through the slot and connect to the brush



7. Install the plastic cover



8. Install Vacuum Motor Outer Cover



9. Install vacuum Motor on to the vacuum housing



10. Route vacuum motor power cord and secure to table with plastic holders

Vacuum Brushes Installation (New Version)

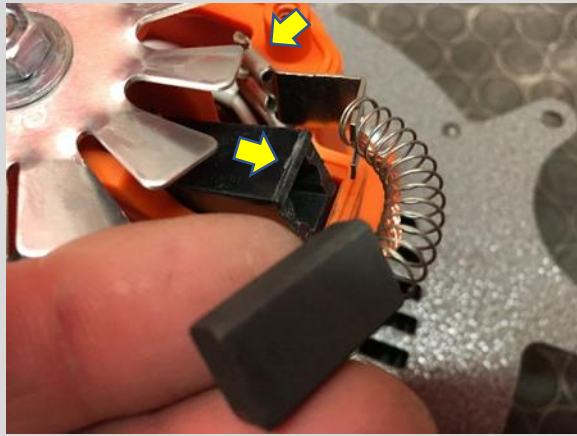

1. Connect the vacuum brush to the connectors and insert into the vacuum brush holders.



2. Lower the brush holders up to secure the brushes in place.



3. Install the vacuum end cover

Support Arm Assembly and Installation



1. Mount support arm to the table frame



2. Route the saw motor power cord through the support arm



3. Route the vacuum motor power cord through the support arm

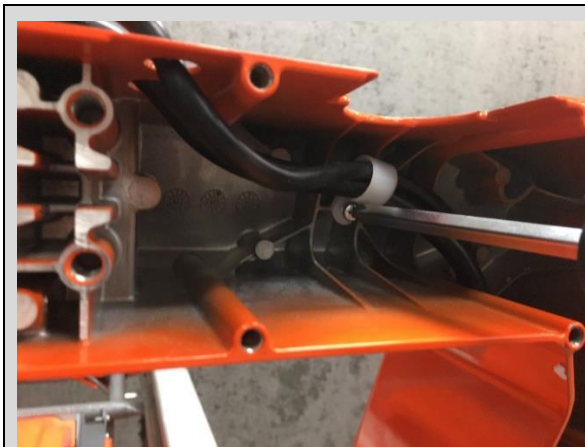

4. Secure the saw and vacuum motor power cord to the support arm with a cord clamp



5. Route vacuum hose



6. Install vacuum hose end connection



7. Connect vacuum hose to vacuum suction

Pivot Arm Assembly and Installation



1. Insert the torsion spring sleeve into the torsion spring



2. Set the torsion spring and sleeve into the gear housing and position into the motor pivot mount.



NOTE: Ensure the spring is relaxed, with no tension and the spring ends are in their perspective slots on the motor pivot mount



3. Slide the pivot shaft through the motor pivot mount and torsion spring sleeve. Tap with a soft head hammer



4. Insert the adjustment screw into the slot on the support arm



5. Position the motor pivot mount with the gear housing into the support arm and tighten the adjustment screw to allow the motor pivot arm to slide into position



6. Loosely tighten the motor pivot mount screws to the support arm



7. Verify the pivot shaft is flush with the outer face of the motor pivot mount



8. Insert and tighten the pivot shaft set screw in the motor pivot mount

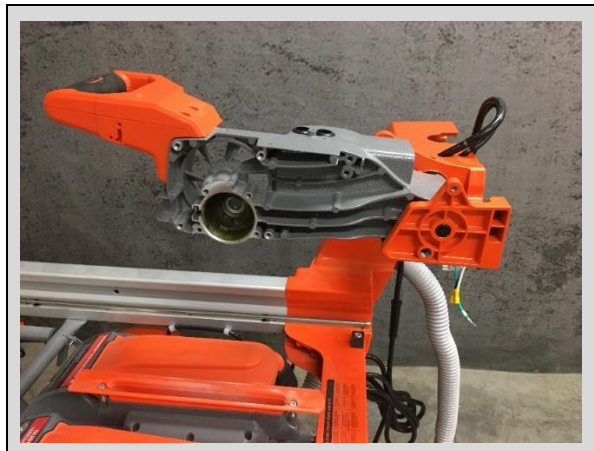

9. Lower and lock the gear housing in the down/cutting position

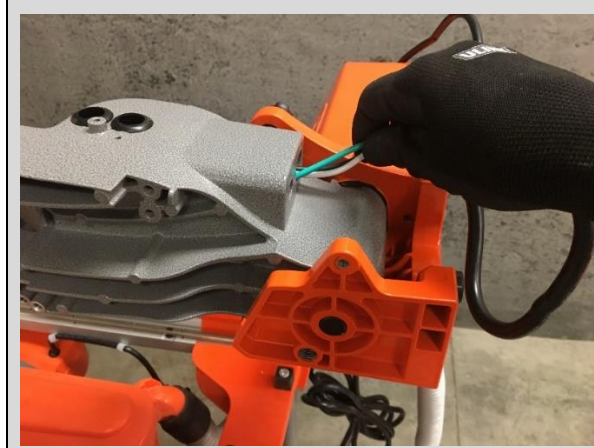

10. Route the saw motor power cord into the saw motor side of the gear housing back



11. Route the vacuum power cord into the blade side of gear housing back

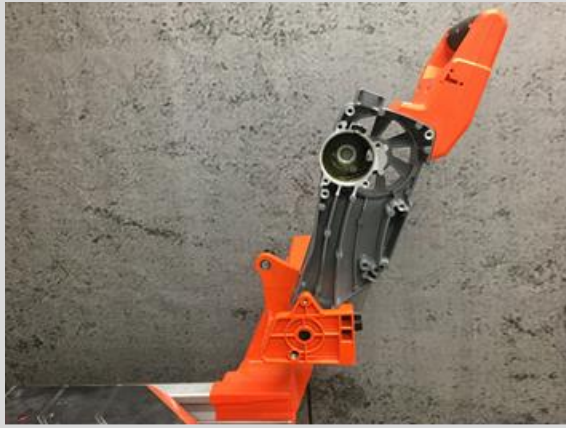

12. Unlock and raise the gear housing to the fully open position



13. Route the vacuum motor power cord through the lower opening of the gear housing top



14. Route the saw motor power cord through the upper opening of the gear housing top

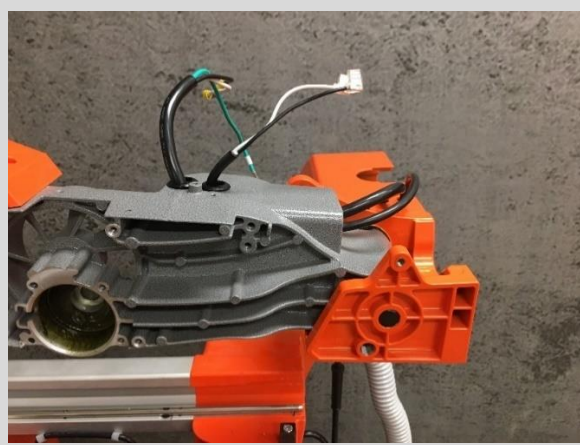

15. Lower and lock the gear housing to the cutting position both the saw and vacuum power cord should be protruding

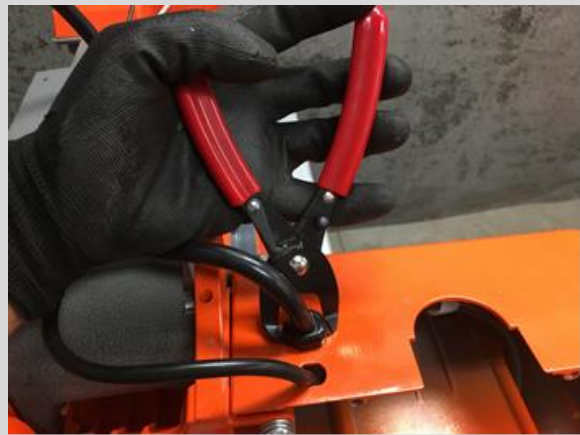

16. Using relief strain pliers, install the cord grips on the saw power cord into the support arm

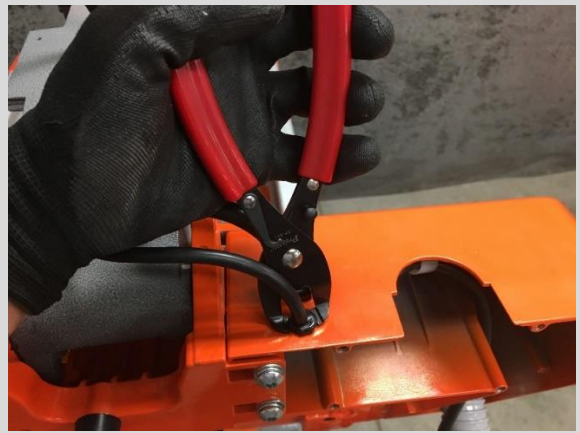

17. Install the cord grips on the vacuum power cord on the support arm

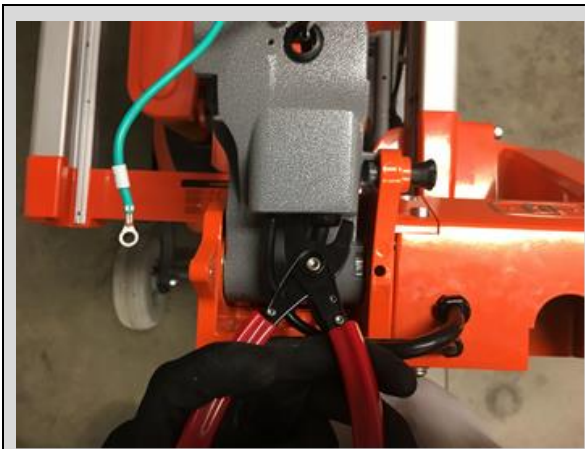

18. Install the cord grips on the saw motor power cord on the gear housing

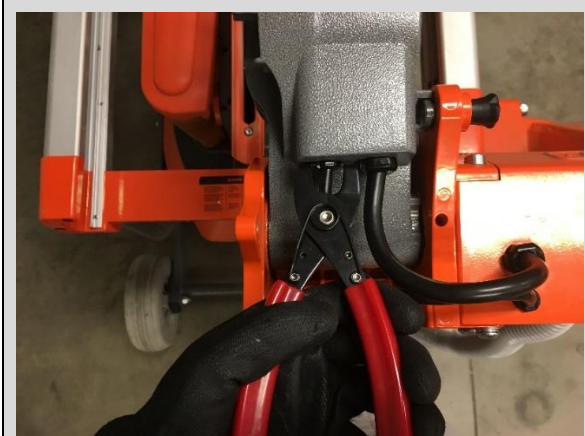

19. Install the vacuum power cord on the gear housing



20. Secure both the saw and vacuum power cord under the gear housing with a cord clamp

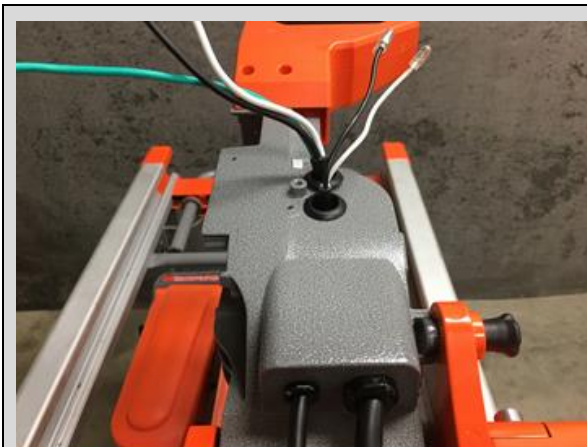

NOTE: the saw motor and vacuum power cords should have just a small portion of the protective jacket exposed once all the cord grips and cord clamps have been installed.

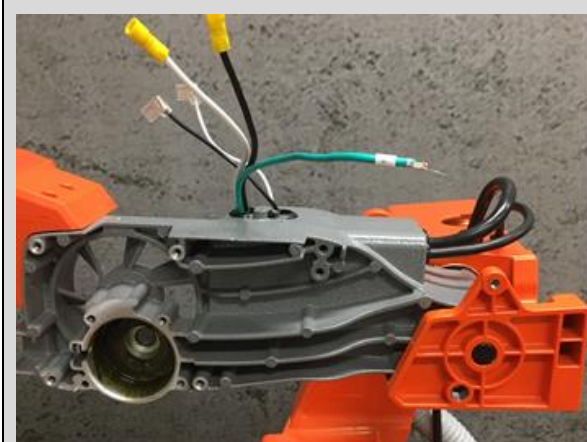

NOTE: in this picture, notice that just the colored conductors are visible above the gear housing



21. Lower the gear housing to the cutting position and install the set screw in the motor pivot mount

Saw Motor Armature Installation

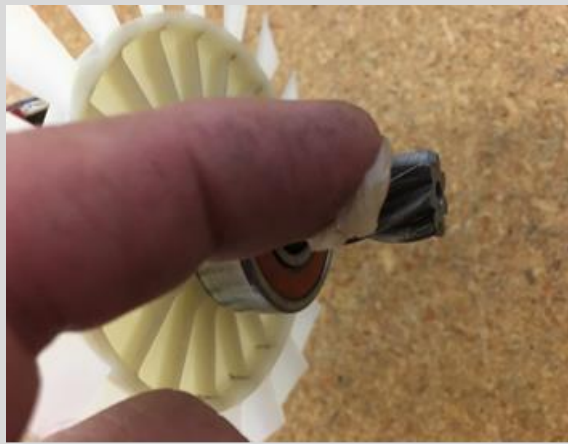

1. Apply general purpose grease on the armature output shaft end



2. Insert the armature output shaft into the gear housing



3. Install the rubber bushing on the armature end bearing

Saw Motor Stator Assembly (Original Version)



1. Route the saw motor brush WHITE JUMPER in the saw motor housing and connect to the brush connector

NOTE: The WHITE JUMPER connector/wire will not be required when installing the NEW Style STATOR



The OLDER version of the iQMS362 Stator looked like the picture with BLACK input and GRAY Brake Output and a single connector for one of the brushes. It needed a WHITE Jumper Wire for return to connect to the PCB.



The NEW version of the iQMS362 Stator has a BLACK Input and WHITE Return along with a connector for EACH Brush.

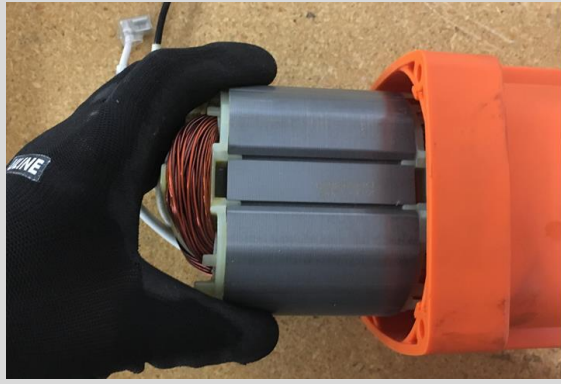

4. Carefully slide the saw motor stator into the saw motor housing

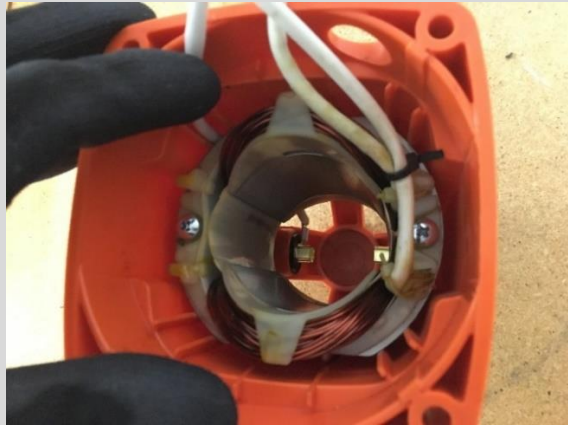

5. Secure the stator to the saw motor housing



6. Route the brush connector and the stator conductors through the saw motor housing assembly



7. Slide the assembled saw motor housing and stator over the armature and flush with the gear housing



8. Secure the saw motor housing assembly on to the gear housing with screws on all corners



9. Insert the Saw Motor Brushes



10. Install the Saw Motor brush covers

SAW STATOR ASSEMBLY AND INSTALLATION



The OLDER version of the iQMS362 Stator looked like the picture with BLACK input and GRAY Brake Output and a single connector for one of the brushes. It needed a WHITE Jumper Wire for return to connect to the PCB.



The NEW version of the iQMS362 Stator has a BLACK Input and WHITE Return along with a connector for EACH Brush.



1. Insert the stator into the plastic motor case. The winding wires should line up with the hole provide on the plastic case



2. Secure the stator with the retaining screws



3. Route the stator wires through the opening provided



4. Attach the brush conductors located on the rear end of the motor case



5. Install the motor case end cap

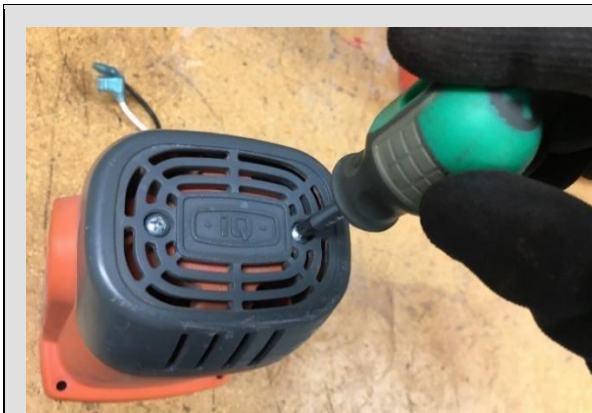

6. Secure the motor end cap with retaining screws



7. Slide the stator and plastic motor case over the armature



8. Secure the motor case and stator with retaining screws

Control Module Installation and Assembly

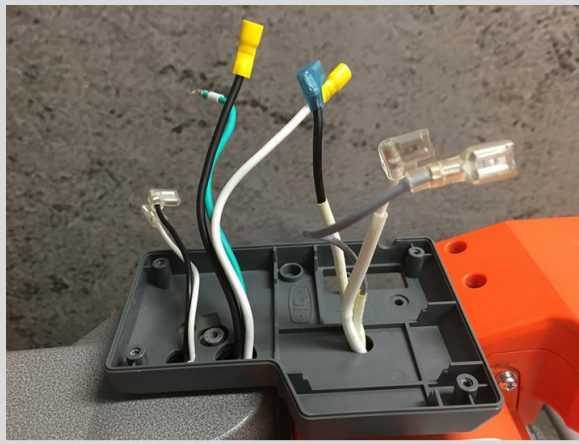

1. Route the saw motor and vacuum motor conductors through the control module base

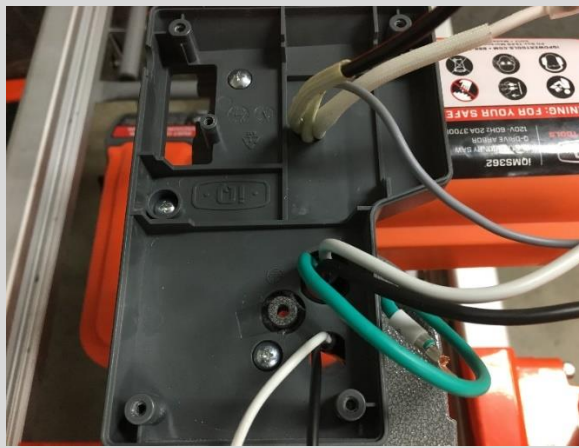

2. Secure the control module base to the gear housing



3. Attach the saw motor ground wire to the gear housing

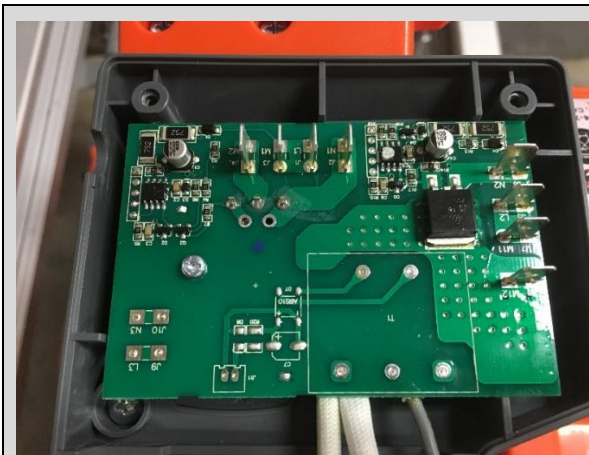

4. Install the printed circuit board in the control module base



5. Connect the saw motor and vacuum power cord connections to the printed circuit board

NOTE: VERIFY CONNECTIONS WITH ELECTRICAL DIAGRAM



6. Connect electrical connections to the ON/OFF switch

NOTE: VERIFY CONNECTIONS WITH ELECTRICAL DIAGRAM



7. Place control module cover

Arbor Assembly Installation



1. Apply general purpose grease to the blade shaft assembly output gear



2. Ensure the gear housing pocket for the blade shaft assembly is free of debris



3. Slide the blade shaft assembly



4. Slide the felt seal and the seal pad into the gear housing slot



5. Slide the spindle lock and button into the compress spring and install into the gear housing



6. Rotate the blade shaft assembly so that it lines up with the gear housing



7. Apply Medium (BLUE) Loctite on the screws to secure the blade shaft assembly on to the gear housing



8. Secure the blade shaft assembly on to the gear housing



9. Rotate the blade assembly shaft by hand to verify it rotates freely. Verify the Armature fan blades also rotate

Guard Guide Rail Assembly and Installation



1. Apply Medium (BLUE) Loctite on the screws to secure the guard guide rail on to the gear housing



2. Secure the guard guide rail on to the gear housing

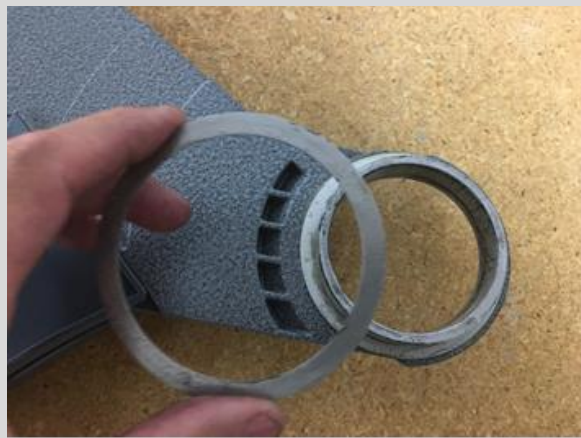

3. Place the washer on the inner dust guard



4. Place the inner blade guard inner blade guard into the inner dust guard



5. Insert the wear washer between the inner blade guard and the inner dust guard

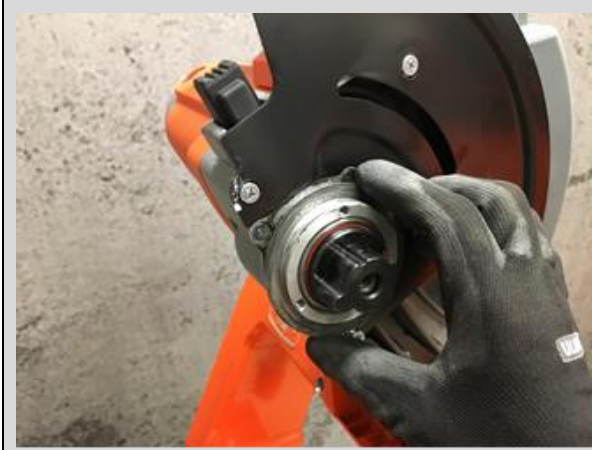

6. Place the washer on the blade shaft assembly



7. Position the inner blade guard and inner dust guard into the blade shaft assembly



8. Route the guard guide rail into the inner blade guard guide rail



9. Rotate both the inner blade guard and inner dust guard 90 degrees so it rides in the guide rail



10. Insert the wear washer between the inner dust guard and the blade shaft assembly

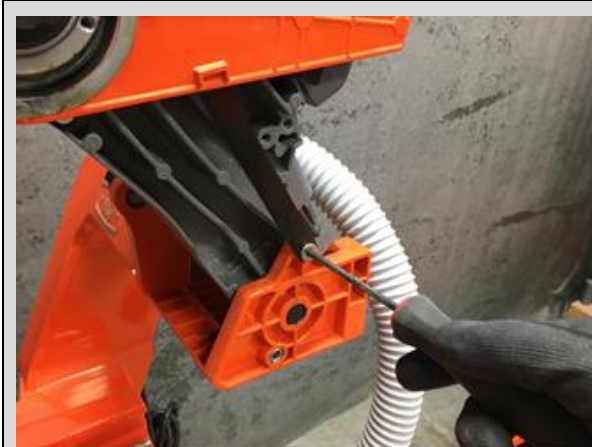

11. Attach the guard link arm to the motor pivot mount



12. Place the blade shaft assembly retaining plate and secure with retaining screws



13. Route the vacuum hose in the support arm



14. Insert the saw power cord into the support arm cover



15. Secure the saw power cord with the cord clamps



1. Connect the vacuum hose on to the inner dust guard

Blade Installation



1. Install the inner blade flange



2. Install the iQ Masonry Blade



3. Install the outer blade flange and blade Lock Nut



4. Install the outer blade cover



5. Close the outer blade cover

IQMS362 ADJUSTMENTS

Sliding Table Upper and Lower Roller Check and Adjustments



1. Remove the sliding table from the track and lay it on the stand with the rollers facing up

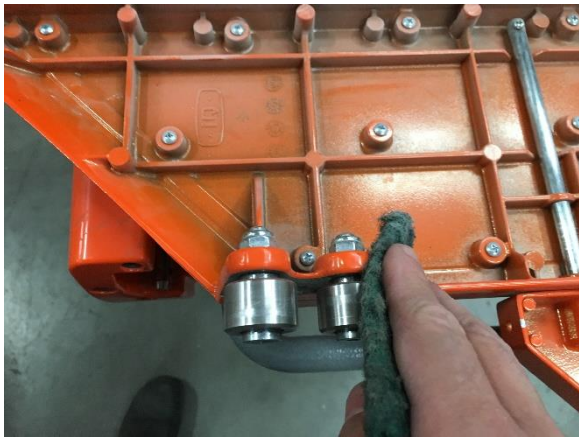

2. Clean the rolling table wheels with Scotch Brite



3. Clean the table track with Scotch Brite



4. Wipe the table track with a lightly damp cloth



5. Insert the sliding table back into the saw stand

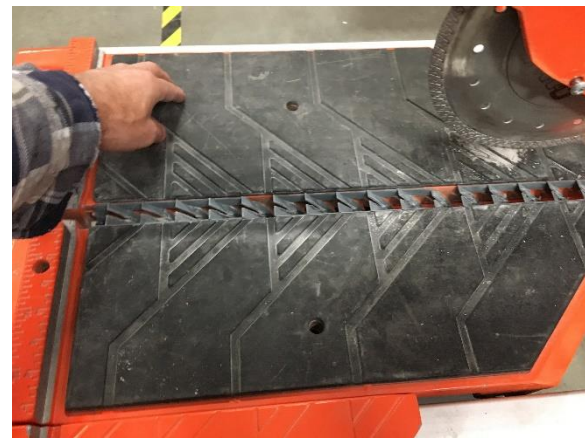

6. Check the table for stability by depressing all four (4) corners

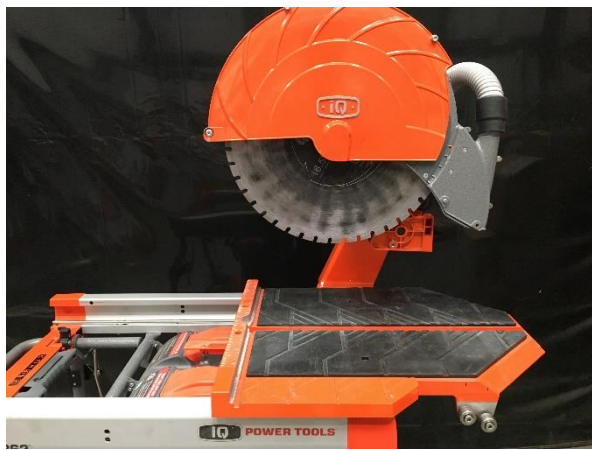

7. Push the sliding table to the forward mechanical stops



8. Depress the area still supported by the table track to check for wobble



9. Pull the sliding table back to the table stop



10. Depress the area still supported by the table track to check for wobble. If the table appears to be stable, **SKIP to Step 27.**



11. If the table is unstable and need adjustment, Remove the rolling table and place it on the stand with the rollers facing up with the front (POINTY END) of the table on the right side



12. Place the long side of a square in the valley of the larger lower guide rollers
 13. Verify all three (3) lower guide rollers are on the same plane by placing straight edge in the valley of all three (3) lower guide rollers and moving the straight edge back and forth. Verify all three (3) lower guide rollers rotate simultaneously



NOTE: The CENTER lower guide roller is the only

adjustable wheel.

14. Loosen the Center lower guide roller slightly so that the eccentric may be adjusted and holds its position.
15. Adjust the eccentric to raise or lower the center lower guide roller as needed



16. Verify all three (3) lower guide rollers are on the same plane by placing straight edge in the valley of all three (3) lower guide rollers and moving the straight edge back and forth. Verify all three (3) lower guide rollers rotate simultaneously. Repeat previous step until satisfied

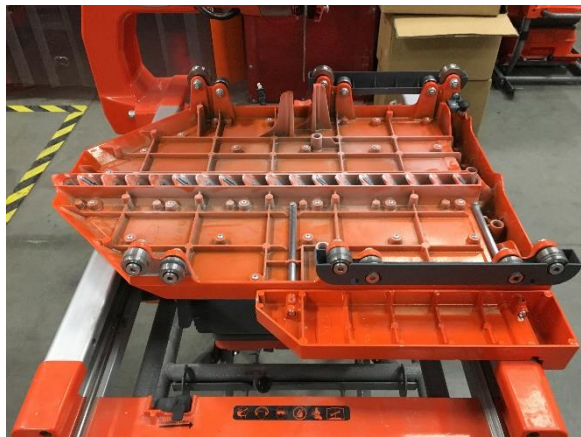

17. Flip the rolling table so the front (POINTY END) of the table is now on the left side

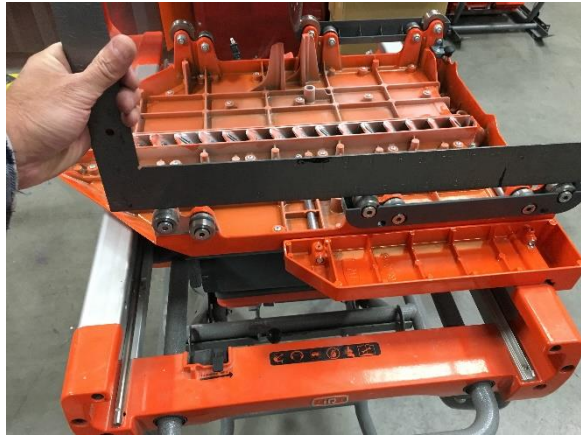

18. Place the long side of a square in the lower guide rollers

NOTE: the lower guide rollers are above the upper rollers since the rolling table is upside down

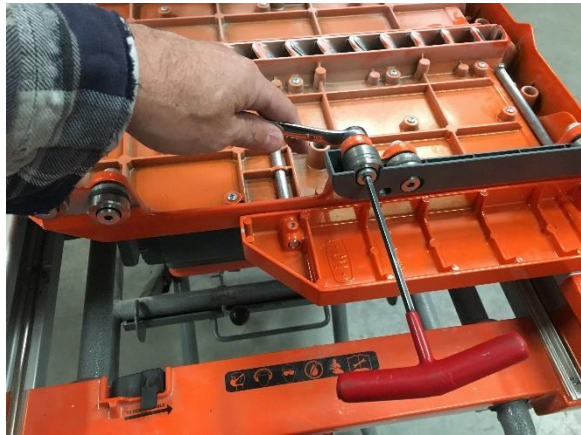

19. Loosen All three (3) lower guide rollers so the eccentrics may be adjusted, and the wheel hold its position.

20. Adjust each lower roller so the lower guide roller is at its lowest position when the table is installed in the saw stand

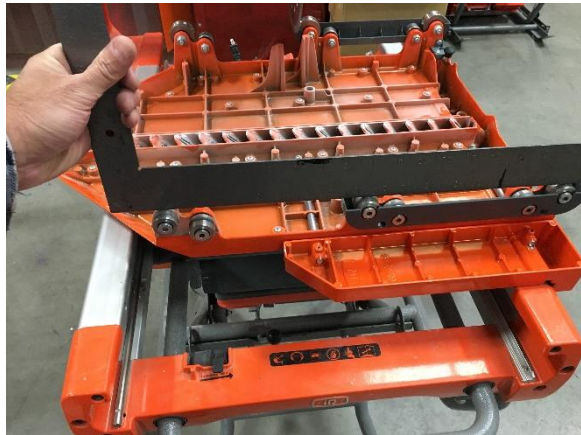

21. Verify all three (3) lower guide rollers are on the same plane. Repeat previous step until satisfied



22. Slide the sliding table into the saw stand



23. Check the adjustment on each upper guide rollers by attempting to roll the wheel while applying some pressure on top of the table. If the upper guide roller spins freely, the eccentric will need to be adjusted up. If the upper guide roller does not turn, the eccentric will need to be adjusted down. The upper guide roller should contact the upper end of the channel with slight friction for proper adjustment. REPEAT for ALL Six (6) sliding table upper rollers



24. Push the sliding table forward to the mechanical stop and check adjustment by depressing rear section of the table. Play should be very minimal



25. Pull the sliding table back to the table stop and check adjustment by depressing rear section of the table. Play should be very minimal

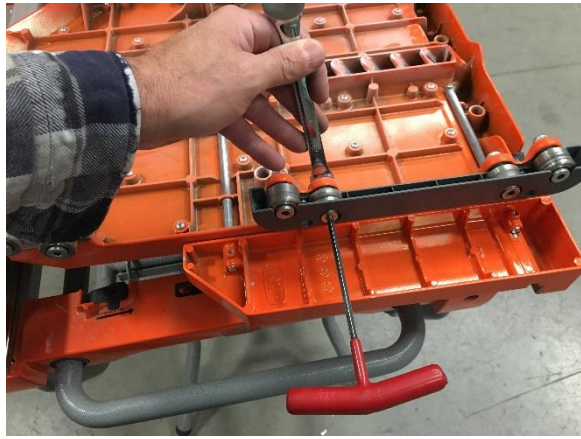

26. Remove the table and tighten all six (6) upper guide wheels, making sure the eccentric stays in the same position

Sliding Table Travel Check and Adjustments

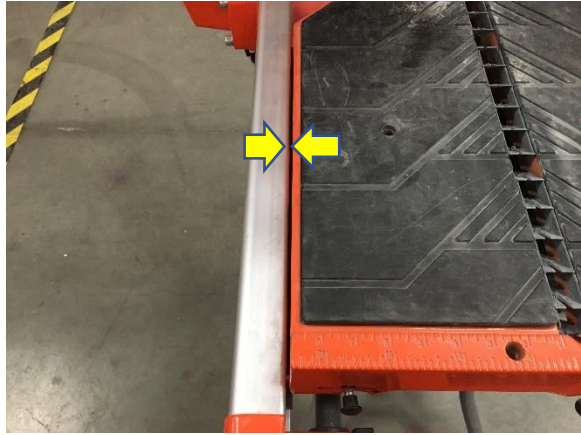

1. Insert the rolling table into the stand and check the gap between the stand and rolling table on the LEFT side of the stand. Verify the distance is consistent from front to back of the sliding table



2. Loosen all six retaining screws that secure the rail to the stand

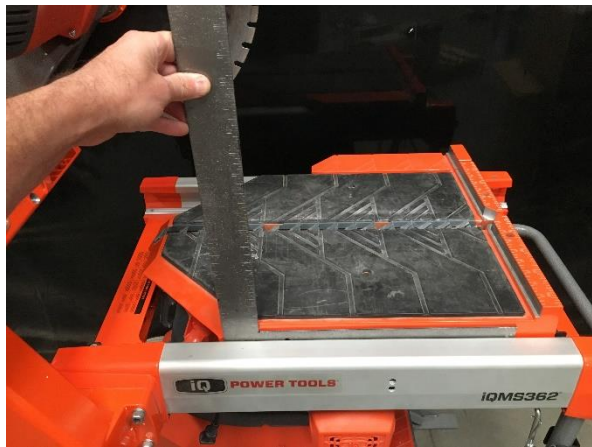

3. Insert the short arm of a square into the gap between the stand and the sliding table

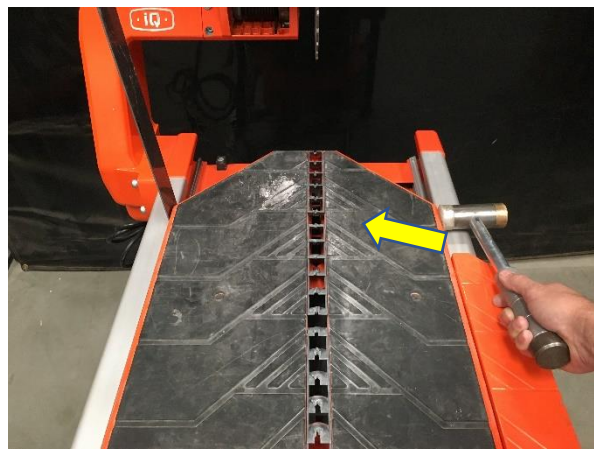

4. Tap the rolling table with a rubber mallet while the square is still in place to ensure the rolling table is parallel with the stand



5. Tighten the inner most retaining screws for the rail to the stand starting with the retaining screw just behind the vacuum motor



6. Then tighten the screw just in front of the vacuum motor



7. Then tighten the screw just behind the first screw tightened



8. Then tighten the screw in front of the second screw tightened



9. Push the sliding table forward so the front lower guide wheel is on the edge of the rail guide

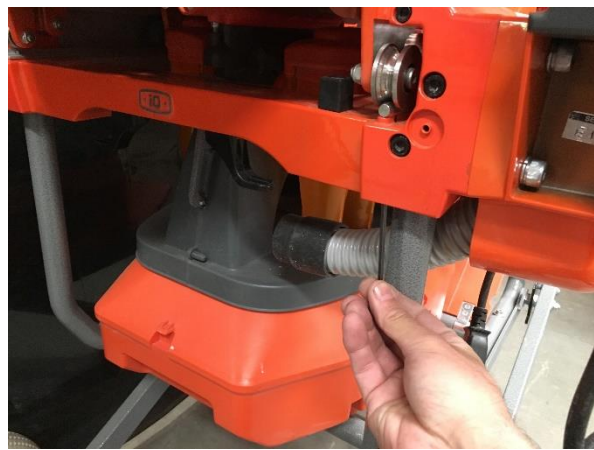

10. Tighten the retaining screw on the front edge



11. Pull the sliding table back so the rear lower guide wheel is on the edge of the rail guide



12. Tighten the retaining screw on the back edge



13. Re-Check the gap on the left side by rolling the table back and forth



14. Verify the blade has proper clearance on both sides of the channel

Pivot Arm Squareness Check and Adjustments



1. Lower and lock the cutting arm in the down position



2. Place the inside edge of the long arm of the square against the edge of the saw blade and the outer edge of the short arm of the square along the back fence of the sliding table



3. Ensure the edge of the square is firmly against the blade segments



4. Check the gap on the corner of the sliding table fence. The gap should be less than .016 inches or 0.4 millimeter.



5. Remove the extension, if it is installed



6. Place the inside edge of the long arm of the square against the opposite edge of the saw blade and the outer edge of the short arm of the square along the back fence of the sliding table



7. Ensure the edge of the square is firmly against the blade segments

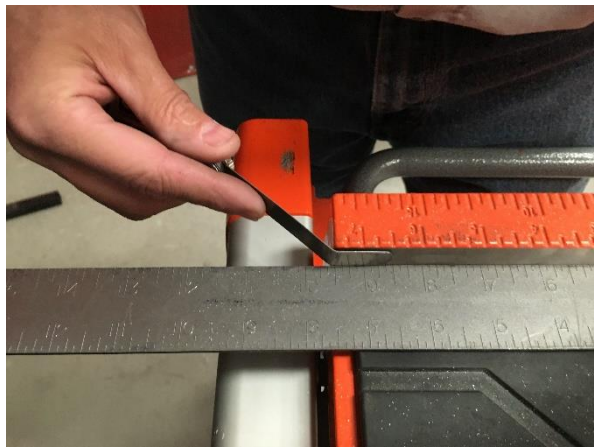

8. Check the gap on the corner of the sliding table fence. The gap should be less than .016 inches or 0.4 millimeter.



9. Remove the Support Arm Back Cover

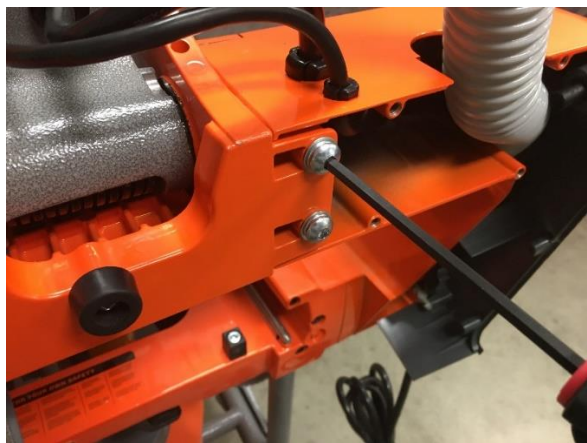

10. Loosen the Pivot Arm retaining screws on the side of the Support Arm Cover

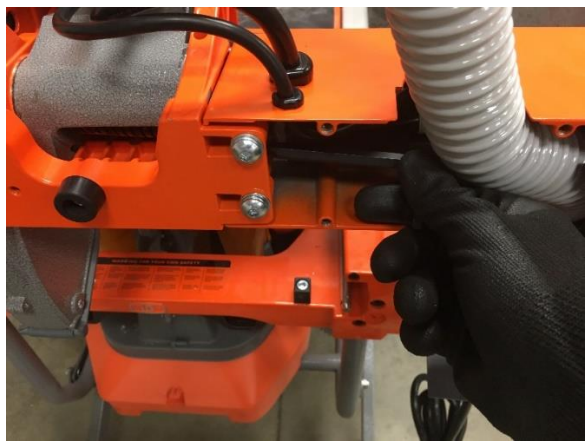

11. To reduce the gap on the right side of the table - Tighten adjustment screw.
to reduce the gap on the left side of the table - Loosen adjustment screw
12. Repeat Steps 41-43 and Steps 45-47 until the gap on both the left and right side are less than .016 inches or 0.4 millimeter.

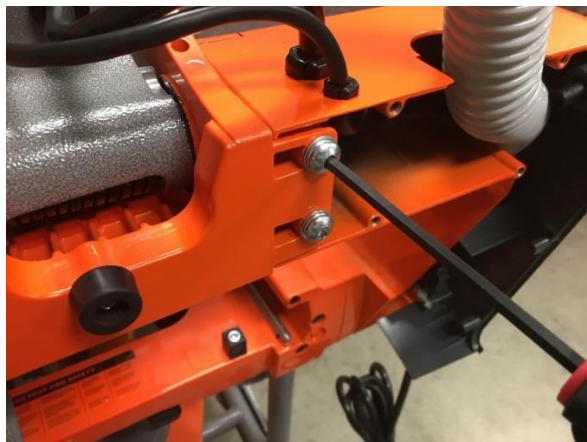

13. Once the gaps on the left and right side are within acceptable tolerance, Tighten the Pivot Arm retaining screws on the side of the Support Arm Cover

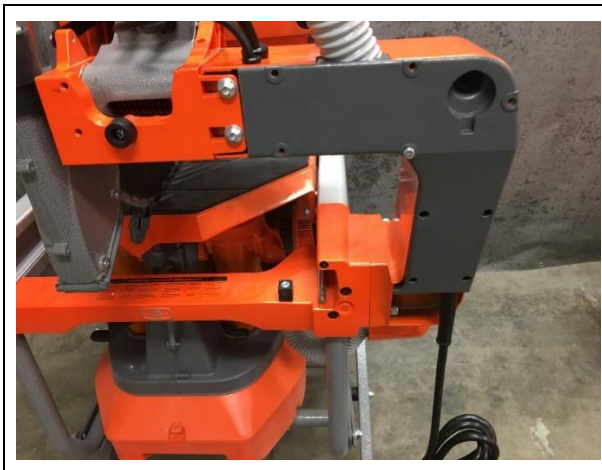

14. Install the Support Arm Back Cover

Table Louver and Vacuum Suction Clearance Check and Adjustment



1. Check sliding table and vacuum intake where the table first enters



2. Adjust so that gap between table and vacuum suction is about 1/32 inch or .03125 inch or 7.9375 millimeter.



3. It should appear as though the sliding table and the vacuum suction are touching



4. Push sliding table forward to the second set screw



5. Adjust the vacuum suction set screw until the gap between the sliding table and the vacuum suction is $\frac{1}{32}$ inch or .03125 inch or .79375 millimeter.



6. Push and pull the sliding table back and fourth to check for smoothness. Make necessary adjustments
7. Tighten final setting on both screws by holding the set jamb nut and tightening the set screw.

Vacuum and Seal Check



1. Connect the vacuum to an extension cord connected to a wall outlet



2. Release the dust tub



3. Verify the dust tub is still attached to the vacuum



4. Engage the dust tub

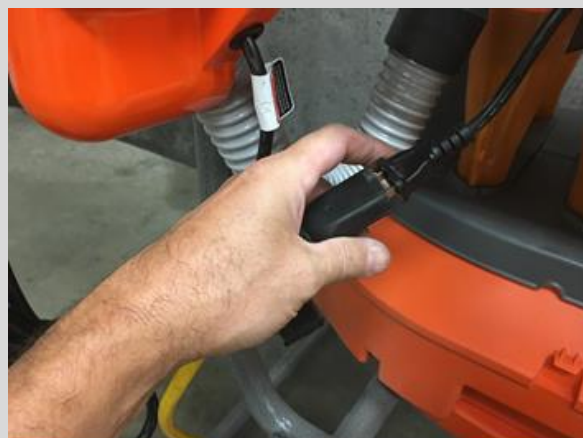

5. Disconnect the vacuum from the extension cord connected to a wall outlet

WIRING DIAGRAM

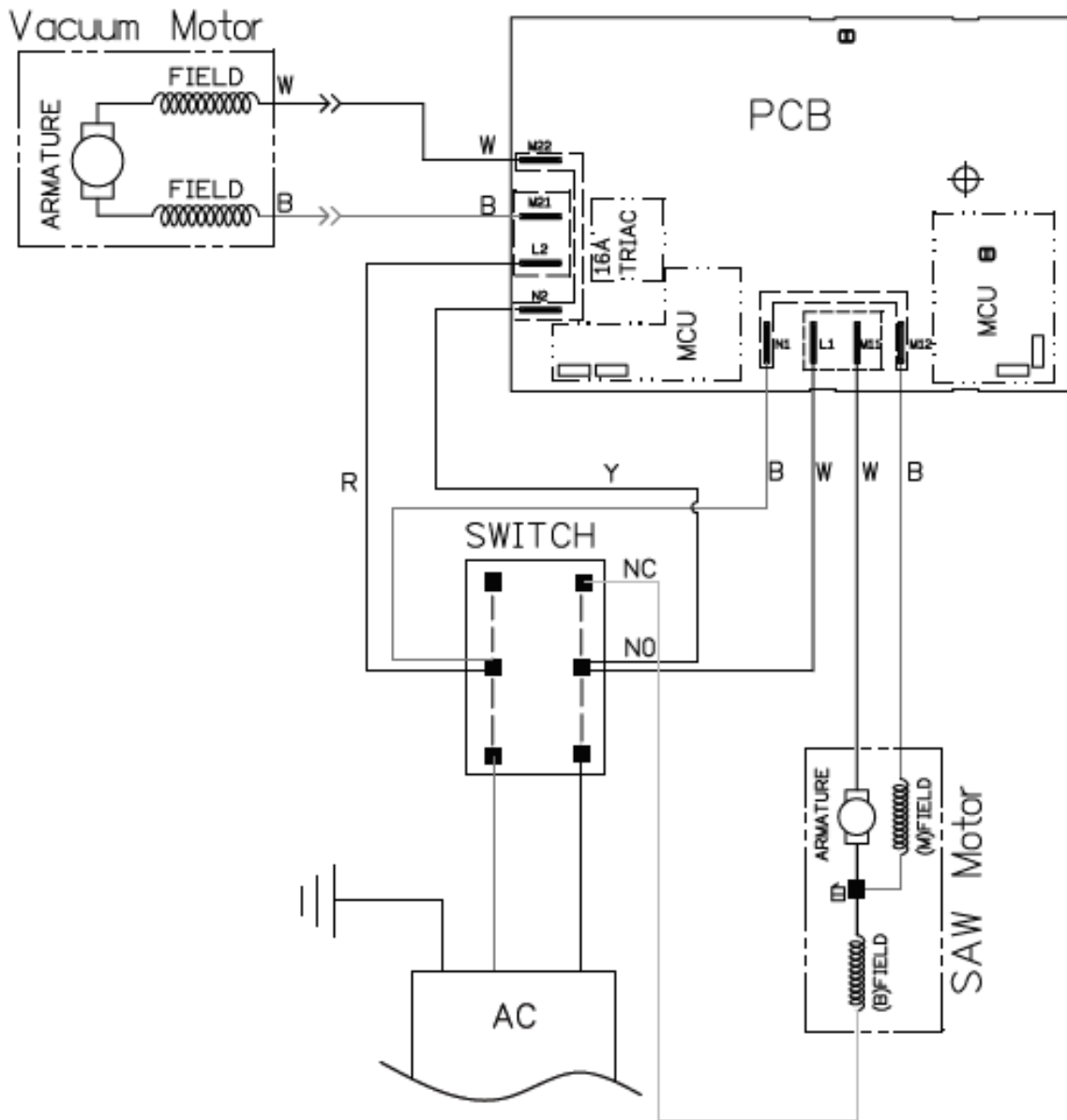

IQMS362 WIRING DIAGRAM WITH UPDATED STATOR

